

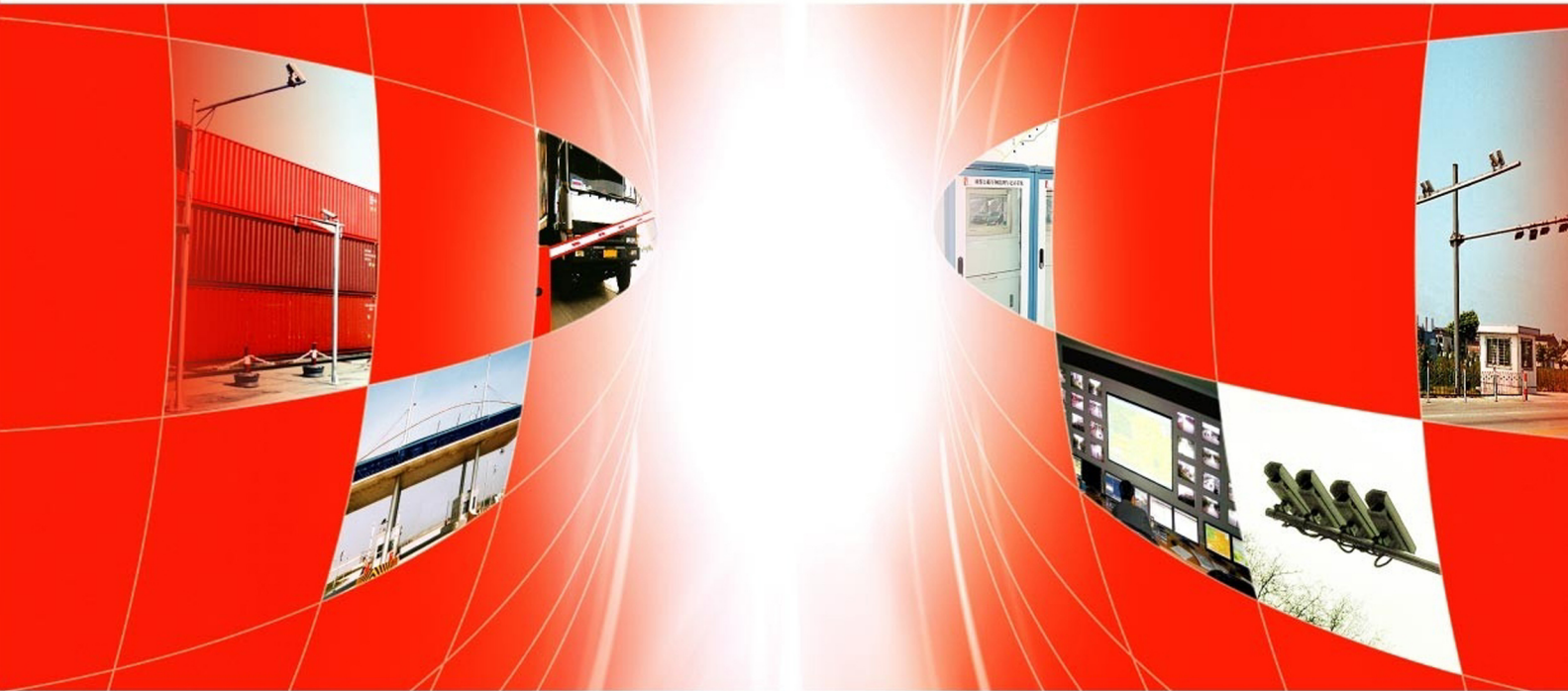

南京三寶科技股份有限公司

NANJING SAMPLE TECHNOLOGY COMPANY LIMITED*

(a joint stock limited company incorporated in the People's Republic of China with limited liability)



PLACING OF H SHARES

Sponsor



Core Pacific - Yamaichi Capital Limited

Lead Manager

Core Pacific - Yamaichi International (H.K.) Limited

IMPORTANT

If you are in any doubt about this prospectus, you should consult your stockbroker, bank manager, solicitor, professional accountant or other professional adviser.



南京三寶科技股份有限公司 NANJING SAMPLE TECHNOLOGY COMPANY LIMITED*

(a joint stock limited company incorporated in the People's Republic of China with limited liability)

Listing on the Growth Enterprise Market of The Stock Exchange of Hong Kong Limited by way of Placing of H Shares

Number of H Shares under the Placing	:	20,400,000 H Shares, comprising 19,500,000 New H Shares and 900,000 Sale H Shares
Placing Price	:	Not more than HK\$4.60 per H Share and not less than HK\$2.70 per H Share
Nominal value	:	RMB1.00 each
Stock code	:	8287

Sponsor



Core Pacific – Yamaichi Capital Limited

Lead Manager

Core Pacific – Yamaichi International (H.K.) Limited

Co-Lead Managers

Crosby Limited

First Shanghai Securities Limited

Co-Managers

Asian Capital (Corporate Finance) Limited
First Asia Finance Group Limited
Taiwan Securities (HK) Co., Ltd.

CSC Securities (HK) Limited
Grand Vinco Capital Limited
TIS Securities (HK) Limited

The Stock Exchange of Hong Kong Limited and Hong Kong Securities Clearing Company Limited take no responsibility for the contents of this prospectus, make no representation as to its accuracy or completeness and expressly disclaim any liability whatsoever for any loss howsoever arising from or in reliance upon the whole or any part of the contents of this prospectus.

A copy of this prospectus, having attached thereto the documents specified in the paragraph headed "Documents delivered to the Registrar of Companies" in Appendix VIII to this prospectus, has been registered by the Registrar of Companies of Hong Kong as required by section 342C of the Companies Ordinance (Cap. 32 of the Laws of Hong Kong). The Securities and Futures Commission of Hong Kong and the Registrar of Companies of Hong Kong take no responsibility as to the contents of this prospectus or any other documents referred to above.

The Company was incorporated, and its businesses are located, in the PRC. Prospective investors of the Company should be aware of the differences in the legal, economic, and financial systems between the PRC and Hong Kong and that there are different risk factors relating to making an investment in a PRC incorporated company. Prospective investors should also be aware that the regulatory framework in the PRC is different from the regulatory framework in Hong Kong and should take into consideration the different market nature of the shares of the Company. Such differences and risk factors are set out in Appendix VI headed "Summary of relevant PRC and Hong Kong laws and regulations and the Articles of Association" to this prospectus and the section headed "Risk factors" in this prospectus respectively.

Prospective investors of the Placing Shares should note that the Placing Underwriters are entitled to terminate their obligations under the Placing and Underwriting Agreement by notice in writing to the Company given by CPY International (on behalf of the Placing Underwriters), acting as the lead manager of the Placing, upon the occurrence of any of the events set forth in the paragraph headed "Grounds for termination" under the section headed "Underwriting" in this prospectus at any time prior to 6:00 a.m. (Hong Kong time) on the Listing Date. Such events include, but without limitation to, any act of God, war, riot, public disorder, civil commotion or terrorism.

The Placing Price is expected to be fixed on or before 3 June 2004 by agreement between CPY International (on behalf of the Placing Underwriters) and the Company (for itself and on behalf of the Vendor) with reference to market demand for the Placing Shares. The Placing Price is expected to be not more than HK\$4.60 per H Share and not less than HK\$2.70 per H Share. If CPY International (on behalf of the Placing Underwriters) and the Company (for itself and on behalf of the Vendor) are unable to reach an agreement on the Placing Price on or before 3 June 2004, the Placing will not proceed. In such circumstances, an announcement will be issued and published on the GEM website by the Company not later than 4 June 2004.

* for identification purpose only

2 June 2004

CHARACTERISTICS OF GEM

GEM has been established as a market designed to accommodate companies to which a high investment risk may be attached. In particular, companies may list on GEM with neither a track record of profitability nor any obligation to forecast future profitability. Furthermore, there may be risks arising out of the emerging nature of companies listed on GEM and the business sectors or countries in which the companies operate. Prospective investors should be aware of the potential risks of investing in such companies and should make the decision to invest only after due and careful consideration. The greater risk profile and other characteristics of GEM mean that it is a market more suited to professional and other sophisticated investors.

Given the emerging nature of companies listed on GEM, there is a risk that securities traded on GEM may be more susceptible to high market volatility than securities traded on the Main Board and no assurance is given that there will be a liquid market in the securities traded on GEM.

The principal means of information dissemination on GEM is publication on the Internet website operated by the Stock Exchange. Listed companies are not generally required to issue paid announcements in gazetted newspapers. Accordingly, prospective investors should note that they need to have access to the GEM website (www.hkgem.com) in order to obtain up-to-date information on GEM-listed issuers.

EXPECTED TIMETABLE

Price Determination Date (<i>Note 1</i>)	on or before Thursday, 3 June 2004
Announcement of the level of indication of interest in the Placing to be published on GEM website at <i>www.hkgem.com</i> on or about	Monday, 7 June 2004
Deposit of H Share certificates into CCASS on or about (<i>Note 2</i>)	Monday, 7 June 2004
Allotment to placees on or about	Monday, 7 June 2004
Dealings in the H Shares on GEM to commence on	Wednesday, 9 June 2004

Notes:

1. The Price Determination Date is expected to be on or before 3 June 2004. If for any reason, the Placing Price cannot be determined on or before 3 June 2004, the Placing will not proceed.
2. The share certificates are expected to be deposited into CCASS on or about 7 June 2004 for credit to the respective CCASS participants' stock accounts of the Placing Underwriters, the placees or their respective agents. No temporary documents of title will be issued.
3. All times stated herein refer to Hong Kong time.
4. For details of the structure of the Placing, including the conditions in relation thereto, please see the section headed "Structure and conditions of the Placing" in this prospectus.
5. In the event of any changes to the above timetable, an announcement will be made by the Company accordingly.

CONTENTS

You should rely only on the information contained in this prospectus to make your investment decision.

The Company has not authorised anyone to provide you with information that is different from the information contained in this prospectus.

Any information or representation not made in this prospectus must not be relied on by you as having been authorised by the Company, the Vendor, the Sponsor, the Lead Manager, the Placing Underwriters, any of their respective director(s) or any other person involved in the Placing.

The contents at the Company's website at www.sampletech.cn do not form part of this prospectus.

	Page
CHARACTERISTICS OF GEM	i
EXPECTED TIMETABLE	ii
CONTENTS	iii
SUMMARY OF THE PROSPECTUS	I
DEFINITIONS	22
GLOSSARY OF TECHNICAL TERMS	31
RISK FACTORS	34
WAIVER FROM COMPLIANCE WITH THE GEM LISTING RULES	44
INFORMATION ABOUT THIS PROSPECTUS AND THE PLACING	45
DIRECTORS AND SUPERVISORS	50
PARTIES INVOLVED IN THE PLACING	52
CORPORATE INFORMATION	55
INDUSTRY OVERVIEW	57
GENERAL OVERVIEW OF THE GROUP	
Shareholding structure	63
Organisational structure	72
History and development	73
BUSINESS OF THE GROUP	
Business overview	80
Revenue model	81
Tendering and production processes	82

CONTENTS

	<i>Page</i>
Production facilities	84
Provision of video security system solutions	86
Operation of video security system solutions	96
Sales of related computer products	97
Sales, marketing and services	98
Customers	99
Seasonality	103
Suppliers	103
Inventory control	103
Research and development	104
Commercialisation of system solutions	106
Competition	107
Intellectual property rights	108
Awards and honours	111
Impact of the PRC's accession to the WTO	114
Strategic alliance	114
Principal strengths of the Group	115
STATEMENT OF ACTIVE BUSINESS PURSUITS	118
STATEMENT OF BUSINESS OBJECTIVES	
Overall business objectives and strategies	124
Bases and assumptions	125
Implementation plan	125
Reasons for the Placing and the use of proceeds	129
DIRECTORS, SUPERVISORS, SENIOR MANAGEMENT AND STAFF	
Directors	131
Executive Directors	131
Non-executive Directors	132
Independent non-executive Directors	132
Supervisors	133
Independent Supervisors	133
Senior management	134
Compliance officer	135
Audit committee	135
Employees	135
SUBSTANTIAL SHAREHOLDERS AND	
INITIAL MANAGEMENT SHAREHOLDERS	137
Substantial Shareholders	137
Initial Management Shareholders	138
Undertakings	139
Related party transactions	140
Exempted continuing connected transactions	142

CONTENTS

	<i>Page</i>
SHARE CAPITAL	144
FINANCIAL INFORMATION	
Indebtedness	146
Liquidity, financial resources and capital structure	147
Commitments	147
Contingent liabilities	148
Foreign exchange risk	148
Disclosure under GEM Listing Rules 17.15 to 17.21	149
Trading record	150
Management discussion and analysis of trading record	151
Taxation	154
VAT and business tax	155
Property interests	157
Dividend policy	158
Distributable reserves	158
Statutory reserves	159
Working capital	159
Pro forma adjusted net tangible assets	159
No material adverse change	160
UNDERWRITING	161
STRUCTURE AND CONDITIONS OF THE PLACING	164
APPENDIX I – ACCOUNTANTS’ REPORT	I – I
APPENDIX II – PRO FORMA FINANCIAL INFORMATION	II – I
APPENDIX III – PROPERTY VALUATION	III – I
APPENDIX IV – TAXATION	IV – I
APPENDIX V – FOREIGN EXCHANGE	V – I
APPENDIX VI – SUMMARY OF RELEVANT PRC AND HONG KONG LAWS AND REGULATIONS AND THE ARTICLES OF ASSOCIATION	VI – I
APPENDIX VII – STATUTORY AND GENERAL INFORMATION	VII – I
APPENDIX VIII – DOCUMENTS DELIVERED TO THE REGISTRAR OF COMPANIES AND AVAILABLE FOR INSPECTION	VIII – I

SUMMARY OF THE PROSPECTUS

This summary aims to give you an overview of the information contained in this prospectus. As it is a summary, it does not contain all the information that may be important to you. You should read the whole prospectus before you decide to invest in the Placing Shares.

There are risks associated with investing in companies listed on GEM. Some of the particular risks in investing in the Placing Shares are set out under the section headed "Risk factors" in this prospectus. You should read that section carefully before you decide to invest in the Placing Shares.

BUSINESS OVERVIEW

The Group is a major developer and provider of video security system solutions in the PRC targeting on government authorities. Currently, its system solutions are designated for use in (i) the traffic monitoring and control sector; and (ii) the customs logistics monitoring sector in the PRC.

The video technologies adopted by the Group include video data capturing, transmission and processing technologies which involve the utilisation of system solution software to enable, among others, digital video recording, phototaking, video data compression and decompression, various types of image processing and identification and data analyses. The video security system solutions developed by the Group involve the application of those technologies for security, law-enforcement and administrative and regulatory purposes in (i) the traffic monitoring and control sector; and (ii) the customs logistics monitoring sector in the PRC. All system solutions provided by the Group, except for (i) certain ready-made system solutions components purchased from third parties; and (ii) the related computer products as set out in the paragraph headed "Sales of related computer products" under the section headed "Business of the Group" in this prospectus, are developed by the Group.

The Group endeavours to become a prominent provider and operator of video security system solutions in (i) the traffic monitoring and control sector; and (ii) the customs logistics monitoring sector in the PRC. In July 2001, the Company was recognised as a Software Enterprise (軟件企業) by the Jiangsu Information Industry Department (江蘇省信息產業廳). In August of the same year, the Company was also recognised as a Key High and New Technology Enterprise (重點高新技術企業) by the Torch High Technology Industry Development Centre of the Ministry of Science and Technology (科學技術部火炬高技術產業中心). In November 2002, the Company was granted the Qualification Certificate for Construction Companies (Grade three) (建築業企業資質證書(三級)) by the Jiangsu Construction Department (江蘇省建設廳) and was qualified to undertake Intelligent Construction works with contract values of RMB6 million or below. In November 2003, the Company was granted the Qualification Certificate for Computer Information System Integration (Grade three) (計算機信息系統集成資質證書(三級)) and was qualified to be capable of undertaking computer information system constructions independently for small and medium enterprises and co-operatively for large enterprises. In December of the same year, the Company was recognised as an Advanced National Information Industry System Organisation (全國信息產業系統先進集體) by the Ministry of Personnel of the PRC (中華人民共和國人事部) and the MII.

Currently, the Group's revenue is mainly derived from the provision of video security system solutions to its customers on a project basis. Some of the projects undertaken by the Group are obtained through tenders. Generally, the Company would bid for projects in response to tender invitations by the relevant PRC government authorities. The prices of the Group's system solutions would generally be finalised at the end of the bidding process in accordance with the general standard of placing competitive bids.

SUMMARY OF THE PROSPECTUS

The Group also sells some related computer products to its customers. Such related computer products include monitors, cables and wiring, digital cameras, servers and workstations, which are general hardware products required for the Group's video security system solutions. The Group would provide and sell such related computer products to its customers upon request in order to facilitate their usage of the Group's video security system solutions.

Recently, the Group has also commenced operating video security system solutions for some provincial/municipal governments in the PRC. The Directors consider that, as the Group participates in the operation of its system solutions for provincial/municipal governments in the PRC, management fees generated from such participation will broaden the Group's revenue base and provide a recurring revenue stream for the Group.

Upon the successful implementation of the operation of video security system solutions for some provincial/municipal governments in the PRC, the Group's revenue stream will comprise: (i) income derived from the provision of video security system solutions; (ii) management fees derived from the operation of video security system solutions; and (iii) income derived from sales of related computer products. Items (i) and (ii) may be recurring or non-recurring whilst item (iii) is non-recurring in nature.

The Group only provides its video security system solutions in the PRC. As at the Latest Practicable Date, the Group had a sales and marketing team of 36 staff, 4 of whom are sales contact persons stationed in Ningbo in Zhejiang province, Jinan in Shandong province, Xiamen in Fujian province and Beijing respectively. These sales contact persons are responsible for providing timely after-sales and consultancy services to major customers of the Group in these cities.

As a major developer and provider of video security system solutions targeting on the PRC government authorities, the Group's customers includes various traffic monitoring and control departments, public security bureau under various municipalities and customs authorities at various levels in the PRC. The orders from the aforesaid organisations are usually short to medium term projects, which are individual and non-recurring in nature. These projects mostly involve system design, implementation and provision of system solutions and the Group principally obtains such orders by placing competitive bids to the relevant government authorities. Generally, the Company bids for projects in response to tender invitations by relevant government authorities. For each of the three years ended 31 December 2003, the Company tendered for 9, 25 and 20 projects respectively, out of which it successfully bid for 5, 12 and 10 projects respectively.

SUMMARY OF THE PROSPECTUS

The tendering procedure adopted by the Company is illustrated in the following chart:

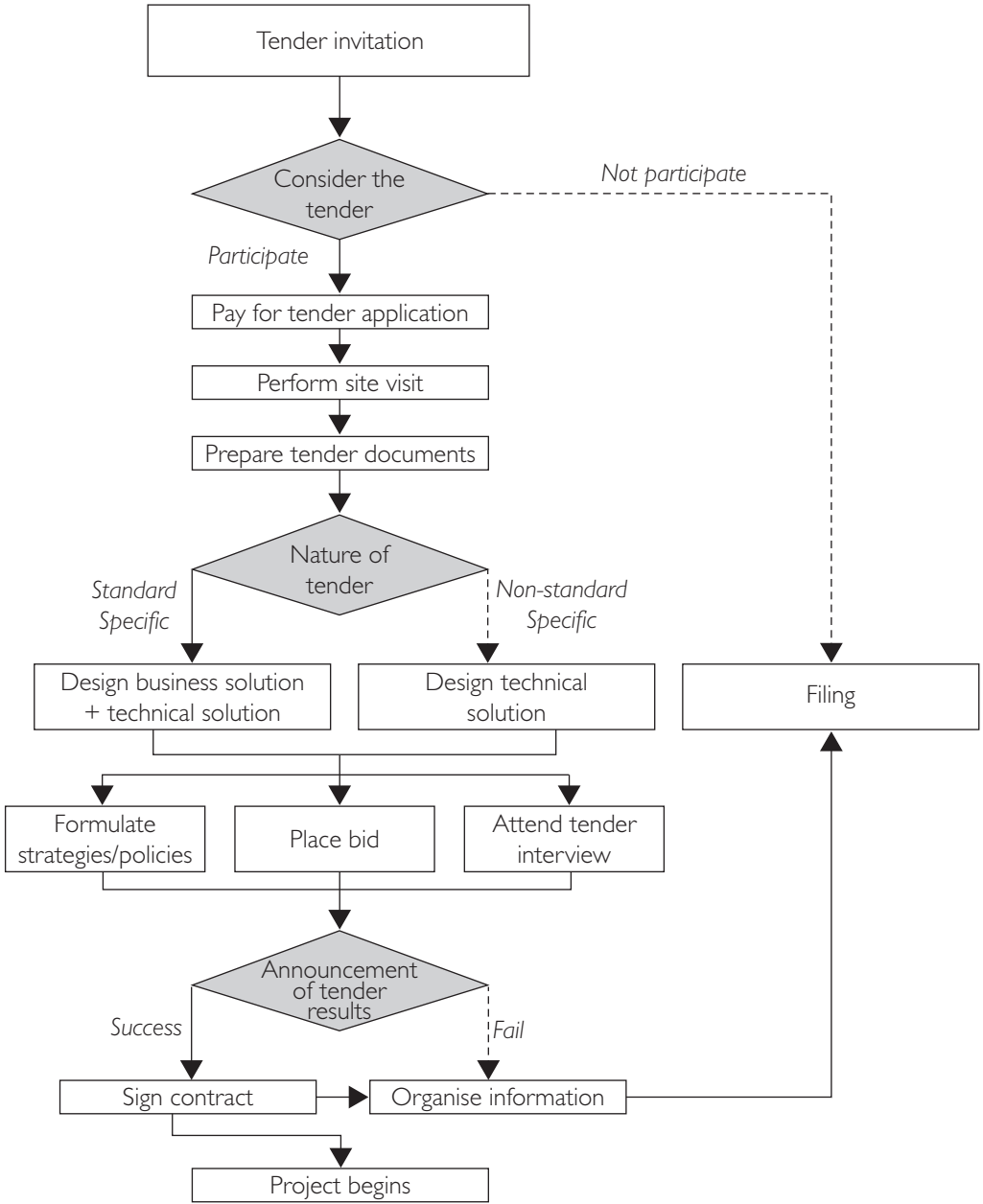

The following diagram illustrates the production process of the Group's video security system solutions after it successfully wins a bid:

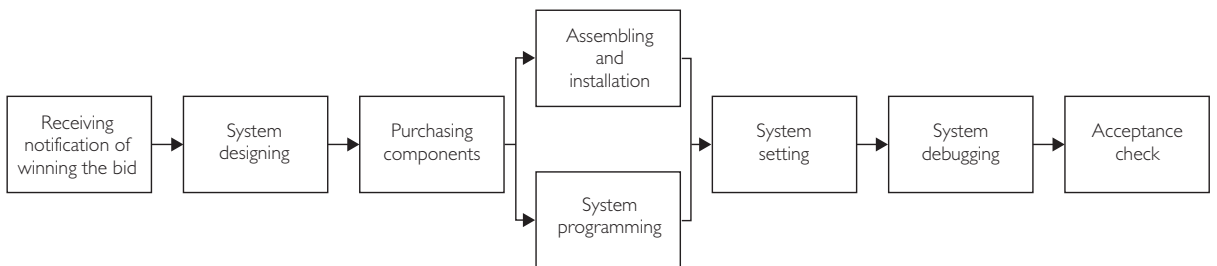

SUMMARY OF THE PROSPECTUS

VIDEO SECURITY SYSTEM SOLUTIONS

During the Track Record Period, the principal video security system solutions developed and provided by the Group in the two major sectors, namely (i) the traffic monitoring and control sector; and (ii) the customs logistics monitoring sector, are as follows:

Traffic monitoring and control sector

- Red Light Overshoot Automatic Recording System (also known as ePolice) (闖紅燈自動記錄系統 (又名電子警察))
- Highway Vehicle Intelligent Monitoring and Recording System (also known as Highway Checkpoint Inspection System) (公路車輛智能化監測與記錄系統 (又名公路卡口系統))
- City Traffic Command Centre System (城市交通指揮中心系統)
- Police Inspection and Reporting Post Information Management System (警務查報站信息管理系統)
- Mobile Vehicles Inspection System (移動式車輛緝查系統)

Customs logistics monitoring sector

- Customs Logistics Monitoring System (海關物流監控系統)
- Customs Export Processing Zone Project (海關出口加工區工程)
- Customs International Wharf Project (海關國際碼頭工程)

The Group was also involved in the provision of video security system solutions for the procuratorial sector and the urban elevator sector in the PRC. However, the Directors consider that the focus on these two sectors should be relinquished as the profit margin for each of these two sectors are relatively low (approximately 25%) compared to those of the other sectors (approximately 40%) and there is limited room for further market penetration. Accordingly, the Group re-allocated its resources to the development and provision of video security system solutions for other sectors.

The Group has not been engaged in the provision of any on-going after-sales services or maintenance services in support of its video security system solutions for the procuratorial sector and the urban elevator sector after the sale of these two sectors of the business.

HISTORY AND DEVELOPMENT

Sample System, the predecessor of the Company, was established as a limited liability company on 30 December 1997. Upon establishment, it had a registered capital of RMB5 million and was held as to approximately 20% by Sample Industry, approximately 20% by Sample Commerce City, approximately 40% by Hu Jia Yong (胡家永) and approximately 20% by Qi Tong Lin (祁同林). At that time, Sample System was principally engaged in the business of R&D, distribution and sale of traffic monitoring and control products.

SUMMARY OF THE PROSPECTUS

On 10 December 1999, Sample Industry, Sample Commerce City, Hu Jia Yong (胡家永), Qi Tong Lin (祁同林), Nanjing Zhongbei and Sha Min (沙敏) entered into a share transfer and capital increase agreement pursuant to which they agreed, inter alia, that (i) Hu Jia Yong (胡家永) should transfer the RMB2 million equity interest held by him in Sample System (representing 40% of the registered capital of Sample System at that time) to Sample Industry at a consideration of RMB2 million; (ii) Qi Tong Lin (祁同林) should transfer the RMB230,000 equity interest held by him in Sample System (representing 4.6% of the registered capital of Sample System at that time) to Sample Industry at a consideration of RMB230,000; (iii) Qi Tong Lin (祁同林) should transfer the RMB390,000 equity interest held by him in Sample System (representing 7.8% of the registered capital of Sample System at that time) to Sample Commerce City at a consideration of RMB390,000; and (iv) Qi Tong Lin (祁同林) should transfer the RMB380,000 equity interest held by him in Sample System (representing 7.6% of the registered capital of Sample System at that time) to Sha Min (沙敏) at a consideration of RMB380,000.

Pursuant to the share transfer and capital increase agreement dated 10 December 1999, Sample Industry, Sample Commerce City, Hu Jia Yong (胡家永), Qi Tong Lin (祁同林), Nanjing Zhongbei and Sha Min (沙敏) also agreed to increase the registered capital of Sample System from RMB5 million to RMB38 million which should be satisfied by way of injection of intangible asset and cash as to RMB13.24 million by Sample Industry and cash as to RMB19.76 million by Nanjing Zhongbei. According to a capital verification report (蘇盛會驗(2000)010-2) dated 31 January 2000, the RMB13.24 million capital injection by Sample Industry consisted of intangible assets in the form of non-patented technology (as to RMB8.3 million) and RMB4.94 million cash. The non-patented technology was valued by a PRC registered asset valuer, an Independent Third Party, in an asset valuation report (寧永會評報(1999)057), at RMB13.9 million.

On 11 March 2000, Sample Information System Engineering was established by Sample Computer Technology and Huadong Electronics with a registered capital of RMB22 million which was owned as to 43% by Huadong Electronics and as to 57% by Sample Computer Technology. The registered capital of Sample Information System Engineering was fully paid up by Huadong Electronics on 26 January 2000 and Sample Computer Technology on 31 January 2000 and 29 February 2000. In October 2000, Huadong Electronics agreed to transfer its 43% equity interest in Sample Information System Engineering to Sample Industry at a consideration of RMB9.46 million. In November 2001, Sample Industry agreed to transfer its 23% equity interest in Sample Information System Engineering to Sample Computer Technology at a consideration of RMB5.06 million. After the completion of the transfer, Sample Information System Engineering was owned as to 80% by Sample Computer Technology and as to 20% by Sample Industry.

On 16 June 2000, Sample Industry and Nanjing Zhongbei entered into an agreement pursuant to which Nanjing Zhongbei agreed to transfer its RMB9.625 million equity interest in Sample Computer Technology to Sample Industry at a consideration of RMB9.625 million as Nanjing Zhongbei had no intention to become the controlling shareholder of the Company and involve actively in the daily management of the Company.

On 30 July 2000, Sample Industry, Huadong Electronics and Nanjing Daily entered into an agreement pursuant to which Sample Industry agreed to transfer its RMB10.135 million equity interest in Sample Computer Technology (representing approximately 26.7% of the registered capital of Sample Computer Technology) to Huadong Electronics at a consideration of RMB12 million. Sample Industry also agreed to transfer its RMB760,000 equity interest in Sample Computer Technology (representing 2% of the registered capital of Sample Computer Technology) to Nanjing Daily at a consideration of RMB1.8 million.

SUMMARY OF THE PROSPECTUS

Sample Computer Technology was converted to a joint stock limited company in the name of the Company. Such conversion was approved by the shareholders of Sample Computer Technology pursuant to a resolution dated 12 October 2000 and was approved by the Nanjing People's Government (南京市人民政府) pursuant to an approval document (寧政覆[2000] 119號) dated 28 December 2000. The conversion was registered with the Nanjing Administration for Industry and Commerce (南京市工商行政管理局) and a business licence was issued on 29 December 2000.

On 7 November 2001, Golden Dragon Software was established by the Company and Qi Tong Lin (祁同林) with a registered capital of RMB6 million. It was owned as to 95% by the Company and 5% by Qi Tong Lin (祁同林).

On 20 August 2002, Sample Industry's registered capital was increased to RMB33 million. Sha Min (沙敏), Chang Yong (常勇), Guo Min Ke (郭明科), Zhu Xiao Hui (朱曉暉) and Cai Long (蔡龍) were elected as directors of Sample Industry. On the same day, Sample Industry changed its name to Sample Group with a registered capital of RMB33 million.

AWARDS AND HONOURS

The Group is strong in developing its video security technologies and has won a number of awards of excellence and technological progress at provincial and municipal levels. The Directors consider that such awards and honours obtained by the Group signified its strengths in the development of its video security system solutions applying in (i) the traffic monitoring and control sector; and (ii) the customs logistics monitoring sector. Those awards and honours also represent the recognised position of the Group in the industry and market awareness of its video security system solutions. The awards granted by institutions also serve as an indicator of the quality of the video security system solutions developed by the Group. The key awards and honours received by the Group are set out as follows:

Date/Year of grant	Awards and honours	Awarding body
April 2000 (Note)	Highway Vehicle Monitoring and Recording System (公路車輛監測與記錄系統) was awarded State Key New Products (國家重點新產品)	The Ministry of Science and Technology of the PRC, the State Administration of Taxation, the State Quality and Technology Supervision Bureau, the Ministry of Foreign Trade and Economic Co-operation of the PRC and the State Environment Protection Administration (中華人民共和國科學技術部，國家稅務總局，國家質量技術監督局，中華人民共和國對外貿易經濟合作部及國家環境保護總局)
April 2000	Highway Vehicle Monitoring and Recording System (公路車輛監測與記錄系統) was awarded State Torch Program Project (國家級火炬計劃項目)	Torch Hi-Tech Industry Development Centre of the Ministry of Science and Technology (科學技術部火炬高技術產業開發中心)

Note: The award was granted to Sample Industry, the entity which supplied the system at the time of receiving the award. Since February 2000, the system has been supplied by the Company.

SUMMARY OF THE PROSPECTUS

Date/Year of grant	Awards and honours	Awarding body
August 2001	Key High and New Technology Enterprise Certificate (重點高新技術企業證書), a recognition that the Group is supported by the PRC government's policy in promoting high and new technologies	Torch High Technology Industry Development Centre of the Ministry of Science and Technology (科學技術部火炬高技術產業開發中心)
August 2002	Highway Checkpoint System (公路卡口系統) and ePolice were certified as in conformity with the ISO9001:2000 standard	Jiangsu Quality Guarantee Centre (江蘇質量保證中心)
September 2002	Distributive Intelligent Customs Logistics Monitoring System (分佈式智能海關物流監控系統) was recognised as Key Technologies R&D Programme Project (國家科技攻關計劃項目)	The Ministry of Science and Technology of the PRC (中華人民共和國科學技術部)
December 2002	High and New Technology Enterprise Recognition Certificate (高新技術企業認定證書), a recognition that the Group is supported by the PRC government's policy in promoting high and new technologies	Jiangsu Science and Technology Department (江蘇省科學技術廳)
December 2003	Advance National Information Industry System Organisation (全國信息產業系統先進集體), an honour as to the Group's contribution to the development of information industry in the PRC	The Ministry of Personnel of the PRC and the Ministry of Information Industry of the PRC (中華人民共和國人事部及中華人民共和國信息產業部)

SUMMARY OF THE PROSPECTUS

PRINCIPAL STRENGTHS OF THE GROUP

The mission of the Group is to be a market leader in the provision and operation of video security system solutions for the traffic monitoring and control sector and the customs logistics monitoring sector in the PRC. The Group, through such business orientation and backed by the prospects of the video security market in the PRC, is committed to excel in the industry to provide quality video security system solutions to the PRC government authorities and private enterprises in the PRC.

The Directors consider the Group's principal strengths are: (i) its video security technology; (ii) its experience in the traffic monitoring and control sector and the customs logistics monitoring sector; (iii) its management and R&D team; and (iv) the Company's shareholder background; which are detailed as follows:

(1) The Group's video security technology

The Group has competitive strengths in developing technologies of real-time image/video capturing, encoding, decoding identification and transmission, and web services. This has enabled the Group to respond promptly to market needs. The Group has won a number of awards of excellence and technological progress awards at provincial and municipal levels. The Company is recognised as a Key High and New Technology Enterprise (重點高新技術企業) by the Ministry of Science and Technology of the PRC (中華人民共和國科學技術部). It is also qualified as a Software Enterprise (軟件企業) by the Jiangsu Information Industry Department (江蘇省信息產業廳), a provincial qualification that entitled the Company to VAT benefit. The Company is the supplier of two State Key New Products (國家重點新產品), namely Wide Area Digital Supervision Alarm System (廣域數字化報警系統) and Highway Vehicle Monitoring and Recording System (公路車輛監測與記錄系統). State Key New Products (國家重點新產品) are products that fulfil the State's industrial requirements and are first researched and developed in the PRC. The Group's Highway Vehicle Monitoring and Recording System (公路車輛監測與記錄系統) was awarded State Key New Product (國家重點新產品) in the PRC and is qualified under the State Torch Program Project (國家級火炬計劃項目). In addition, the Group is responsible for the operation of the Transportation Safety and Traffic Intelligent System Engineering Technical Centre of Jiangsu Province (江蘇省運輸安全與交通治安智能系統工程技術中心).

(2) The Group's experience in the traffic monitoring and control sector and the customs logistics monitoring sector

Since its establishment, the Group has put much emphasis on the development of system solutions that met the needs of the government authorities and private enterprises in the PRC. In particular, the Group has accumulated experience in the implementation of video security system solutions in the traffic monitoring and control sector and the customs logistics monitoring sector. The Group's Red Light Overshoot Automatic Recording System (ePolice) has been adopted by public security departments in 49 different cities in 14 provinces (Anhui, Fujian, Hebei, Henan, Hubei, Jilin, Jiangsu, Jiangxi, Liaoning, Shandong, Shanxi, Sichuan, Yunnan and Zhejiang) and 2 municipalities directly under the central government (Beijing and Chongqing) of the PRC. The Group's Customs Logistics Monitoring System (海關物流監控系統) has been successfully operated by the customs authorities in 19 out of the 38 State-level EPZs. The Directors believe that these experiences provide the Group with a solid background to implement large scale projects.

SUMMARY OF THE PROSPECTUS

(3) The Group's management and R&D team

Led by Sha Min (沙敏) and Mr. Fu Yu Qing (富煜清), the chairman and the chief technical officer of the Company respectively, the Group's senior management has a good understanding of the video security market and technological trend, which has put the Group in a leading position in developing and applying video security technologies for its system solutions. The senior management is able to keep abreast of the latest market trend to develop and provide video security system solutions that meet the requirements of PRC government authorities and private enterprises in the PRC. As at the Latest Practicable Date, the Group had 172 employees, of whom 35 are R&D personnel. Most of the members of the current R&D team have received tertiary education and are strong in product development and system design and experienced in technical integration.

(4) The Company's shareholder background

Sample Group, a Substantial Shareholder, is a private enterprise equipped with sound and innovative technical know-how and market development capability. Huadong Technology, an A share company listed on the Shenzhen Stock Exchange, is a large key enterprise engaged in the PRC's information technology industry. Nanjing Zhongbei is also an A share listed company in the PRC. The extensive network of these shareholders provide a platform for the Group's development.

OVERALL BUSINESS OBJECTIVES AND STRATEGIES

The Group aims to become a leading provider and operator of video security system solutions in the traffic monitoring and control sector and the customs logistics monitoring sector. To ascertain the prospect and potential of the Group's business in the provision of video security system solutions in the traffic monitoring and control sector and the customs logistics monitoring sector, the Company has engaged CCID Data at a consideration of RMB105,000 in preparing a market research report called Digitalisation of Traffic, Customs and Government sectors in the PRC – Current Investment Conditions and Trends (中國交通、海關、政府行業信息化投資現狀與趨勢) in respect of years 2002 to 2006 (the "Research Report").

The Research Report was issued in October 2002 and forecasts that total investment in the PRC information service market would increase from RMB50.4 billion in 2002 to RMB136.2 billion in 2006 with a compound annual growth rate of approximately 28.2%. According to the Research Report, investments in the intelligent transportation market in the PRC are estimated to increase from approximately RMB9.2 billion in 2002 to approximately RMB20.1 billion in 2005, representing a compound annual growth rate of approximately 29.8%. General Customs Administration of the PRC (中華人民共和國海關總署) also estimates that investment in informationalisation for the customs logistics monitoring sector in the PRC will be approximately RMB13.2 billion during the period from 2001 to 2005, out of which more than RMB5.2 billion will be invested in logistics control, approximately 2.3 billion in electronic services of customs and approximately RMB1.8 billion in electronic services of ports.

In view of the findings of the Research Report, the Group endeavours to continue its focus in the traffic monitoring and control sector and the customs logistics monitoring sector. The Group's system solutions assist the local public security bureaus in the PRC to identify suspected vehicles, locations of reported lost vehicles and undeclared cargos. Such identification function enables the local public security bureaus in the PRC to monitor public security effectively and to reduce possible law-violating activities. The Group will leverage on the opportunities arising from government digitalisation projects and city digitalisation projects to provide

SUMMARY OF THE PROSPECTUS

information value-added services to customers, with a view to maintaining its position in the traffic monitoring and control sector and the customs logistics monitoring sector.

The Group intends to achieve its business objectives by implementing the following strategies:

- Strengthen the research, development and application of the core technologies based on video graphic technology and to maintain its position in the relevant market. Emphasis is placed on the formulation of and compliance with self-developed product standards which had registered with the Standardisation Department of the Nanjing Quality and Technology Supervision Bureau (南京市質量技術監督局標準化處), a domestic official organisation responsible for implementing and supervising national, local and industrial product standards.
- Capitalise on the Group's technical advantage in developing technologies of real-time video capture, video encoding and decoding, video transmission, video identification and web services to develop a series of system solutions.
- Strengthen the Group's management quality and pursue the achievement of ISO9001 quality certification in order to promote corporate image and recognition of its system solutions.
- Build a corporate culture by following the business orientation of the Group, i.e. value the technical expertise of its professionals and emphasise the relationship with its customers to nurture team spirit and adapt to rapid market changes and development of the technology industry.
- Establish a research institute for new technologies and system solutions to improve the technological innovation capacity and upgrade its core technology, which will be financed by government subsidies and the Company's internal resources.
- Strengthen the relationship and co-operation with reputable academic institutions and research institutes. Save as disclosed in this prospectus, the Company currently is not carrying out any negotiation with such academic institutions and research institutes.

SUMMARY OF THE PROSPECTUS

TRADING RECORD

The following table summarises the Group's turnover and results for each of the three years ended 31 December 2003. The summary is prepared on the basis of the information set out in the accountants' report, the full text of which is set out in Appendix I to this prospectus.

	Notes	Year ended 31 December		
		2001 RMB'000	2002 RMB'000	2003 RMB'000
Turnover	1	32,715	62,175	61,836
Cost of sales		(21,988)	(38,256)	(29,096)
Gross profit		10,727	23,919	32,740
Gain on disposal of technical know-how		–	4,381	–
Other operating income		4,002	4,207	7,985
Marketing and promotional expenses		(5,264)	(4,740)	(7,188)
Administrative expenses		(7,909)	(9,852)	(7,798)
Profit from operations		1,556	17,915	25,739
Gain on disposal of a subsidiary		–	–	141
Interest on bank borrowings wholly repayable within five years		(646)	(2,600)	(2,270)
Profit before taxation		910	15,315	23,610
Taxation		(790)	(2,502)	(2,751)
Profit before minority interests		120	12,813	20,859
Minority interests		(55)	(250)	(252)
Net profit for the year		<u>65</u>	<u>12,563</u>	<u>20,607</u>
Dividends	2	<u>–</u>	<u>–</u>	<u>–</u>
Earnings per share – Basic	3	<u>RMB0.14 cents</u>	<u>RMB27.92 cents</u>	<u>RMB45.79 cents</u>

SUMMARY OF THE PROSPECTUS

Notes:

1.

	Year ended 31 December		
	2001	2002	2003
	<i>RMB'000</i>	<i>RMB'000</i>	<i>RMB'000</i>
Turnover comprises:			
Provision of video security system solutions	25,686	49,130	60,875
Sales of related computer products	7,029	13,045	961
	<u>32,715</u>	<u>62,175</u>	<u>61,836</u>

Gross profit is analysed as follows:

	Year ended 31 December		
	2001	2002	2003
	<i>RMB'000</i>	<i>RMB'000</i>	<i>RMB'000</i>
Provision of video security system solutions	10,126	23,202	32,441
Sales of related computer products	601	717	299
	<u>10,727</u>	<u>23,919</u>	<u>32,740</u>

Gross profit margin is analysed as follows:

	Year ended 31 December		
	2001	2002	2003
	Provision of video security system solutions	39.4%	47.2%
Sales of related computer products	8.6%	5.5%	31.1%

2. No dividends have been declared by the Company and its subsidiaries during the Track Record Period except for Sample Information System Engineering which paid a dividend of RMB1,608,000 in 2001, of which RMB691,000 was paid to its then minority owners.
3. The calculation of basic earnings per Share for each of the three years ended 31 December 2003 was based on the Group's net profit of approximately RMB65,000, RMB12.6 million and RMB20.6 million respectively.

The calculation of basic earnings per Share is based on the 45,000,000 Domestic Shares in issue during the period from 1 January 2001 to 31 December 2003.

No diluted earnings per Share are presented as the Company has no dilutive potential shares.

SUMMARY OF THE PROSPECTUS

SHAREHOLDING STRUCTURE AND MORATORIUM PERIOD

The following table illustrates the respective shareholdings and the moratorium periods of the Promoters upon the completion of the Placing (without taking into account any Shares which may fall to be issued upon the exercise of any options granted under the Share Option Scheme):

Shareholder	Date of becoming a Shareholder	Number of Domestic Shares held immediately before the completion of the Placing	Approximate percentage in the registered capital of the Company immediately before the completion of the Placing (%)	Number of Shares held immediately after the completion of the Placing	Approximate percentage in the registered capital of the Company immediately after the completion of the Placing (%)	Total cost of investment (RMB) (Note 7)	Approximate cost per Share (RMB)
Sample Group (Notes 1 and 8)	30 December 1997	18,000,000	40.00	18,000,000	27.91	12,295,000	0.68
Nanjing Zhongbei (Notes 2 and 8)	10 December 1999	12,000,000	26.67	12,000,000	18.60	10,135,000	0.84
Huadong Technology (Notes 3 and 8)	30 July 2000	12,000,000	26.67	12,000,000	18.60	12,000,000	1.00
Sample Commerce City (Notes 4 and 8)	30 December 1997	1,650,000	3.66	1,650,000	2.56	1,390,000	0.84
Nanjing Daily (Note 5)	30 July 2000	900,000	2.00	–	–	1,800,000	2.00
Sha Min (沙敏) (Notes 6 and 8)	10 December 1999	450,000	1.00	450,000	0.70	380,000	0.84
Sub-total		45,000,000	100.00	44,100,000	68.37		
Public Shareholders		–	–	20,400,000	31.63		
Total:		<u>45,000,000</u>	<u>100.00</u>	<u>64,500,000</u>	<u>100.00</u>		

SUMMARY OF THE PROSPECTUS

Notes:

- I. Sample Group is a limited liability company established in the PRC on 12 June 1993 with a registered capital of RMB33 million. According to its business licence issued on 20 August 2002, its scope of business is the research, manufacture and sales of electronic products and communication equipment (excluding ground reception unit for satellite), apparatus and devices, and machinery; technological development of computer hardware and software, and technology services; computer network system integration; design and implementation of industry automation projects, investment in electronic technology projects; warehousing and transportation. As at the Latest Practicable Date, the structure of the registered capital of Sample Group is as follows:

Name of shareholder	Approximate percentage in the registered capital of Sample Group	Name of shareholder	Approximate percentage in the registered capital of Sample Group
Sha Min (沙敏)	24.42%	Qi Tong Lin (祁同林)	2.00%
Cai Long (蔡龍)	12.16%	Zong Xin Zhi (宗新志)	2.00%
Sun Huai Dong (孫懷東)	10.15%	Fei Chun Feng (費春風)	1.82%
Zhu Xiao Hui (朱曉暉)	7.39%	Cheng Bo (陳波)	1.70%
Guo Min Ke (郭明科)	5.62%	Fu Yu Qing (富煜清)	0.66%
Yu You Geng (虞友庚)	5.48%	Hong Qi Sheng (洪啟生)	0.61%
Chang Yong (常勇)	4.67%	Liu Wei Ping (劉偉平)	0.61%
Cai Ju Ying (蔡菊英)	4.55%	Ding Jia (丁佳)	0.49%
Liao Qiong (廖瓊)	3.58%	Wang De Hua (王德華)	0.36%
Huang Shen (黃申)	2.86%	Du Jin (杜瑾)	0.36%
Xu Qiao Ling (徐巧玲)	2.79%	Wang Li Sheng (王麗生)	0.33%
Peng Xiu Juan (彭秀娟)	2.52%	Liu Min (劉民)	0.30%
Guo Ya Jun (郭亞軍)	2.27%	Dai Xiao Yu (戴曉玉)	0.30%

Sha Min (沙敏) is an executive Director and the chairman of the Company and directly owns 1.0% equity interest in the Company. He is also a director of Sample Group, Golden Dragon Software and Sample Information System Engineering.

Chang Yong (常勇) is an executive Director. He is also a director of Sample Group, Golden Dragon Software and Sample Information System Engineering.

Guo Ya Jun (郭亞軍) is an executive Director and the deputy general manager of the Company. He is also a director of Sample Information System Engineering.

Qi Tong Lin (祁同林) is a member of the senior management of the Company. He also owns 5% equity interest in and is a director of Golden Dragon Software.

Sun Huai Dong (孫懷東) and Du Jin (杜瑾) are Supervisors.

Fu Yu Qing (富煜清) is a member of the senior management of the Company.

Sample Group has nominated Sha Min (沙敏), Chang Yong (常勇) and Guo Ya Jun (郭亞軍) as the executive Directors and Sun Huai Dong (孫懷東) as a Supervisor.

Sample Group has undertaken to the Company and the Stock Exchange that, during the Lock-up Period, it will not, save as provided in Rule 13.18 of the GEM Listing Rules, (i) dispose of (nor enter into any agreement to dispose of) nor permit the registered holder to dispose of (or to enter into any agreement to dispose of) any of its equity interest in the Company; or (ii) otherwise create (nor enter into any agreement to create) nor permit the registered holder to create (or to enter into any agreement to create) any options, rights, interest, or encumbrances in respect of any such interest.

SUMMARY OF THE PROSPECTUS

Each of the shareholders of Sample Group has undertaken to the Company and the Stock Exchange that he/she will not dispose of (nor enter into any agreement to dispose of) any of his/her equity interest in Sample Group for a period of 12 months from the Listing Date.

2. Nanjing Zhongbei is a joint stock limited liability company established in the PRC on 10 July 1992. Its A shares commenced listing on the Shenzhen Stock Exchange on 6 August 1996. The scope of business of Nanjing Zhongbei is motor vehicle hiring; passenger transportation on highway across provinces and cities; coach hiring; motor vehicle maintenance and repair; vehicle ticket agency; tour services (2nd categories); (design, production and agency service for press, publications and three-dimensional animated advertisement; promoting agent for advertisements on the body of motor vehicle, outdoor and gift commercials; franchised plate for community; sales and complementary services for motor vehicle); motor vehicle accessories; provision of groceries, daily commodities, and stationery; computers and accessories; craftsmanship products (excluding gold and silver ornaments); metal raw materials; ironmongery alternating current power (excluding power booster); building materials (selling); (development, construction and sales of property real estates; leasing of commodity houses; driving training; parking area); training on motor vehicle; chemical engineering products; sales of decorative materials; production and sales of clothing, hats and shoes repairing; property management; interior decoration; (accommodation, food and beverage services, flour, food additives). operations stated in brackets are applicable to branches only; highway transportation; economic information enquiries services; commercial agency.

According to the 2003 annual report of Nanjing Zhongbei, the shareholders of Nanjing Zhongbei which hold an interest of 5% or more are Nanjing Proprietary State-owned Property Management Company (Holdings) Company (南京市國有資產經營(控股)公司) which owns an interest of 28.56% of the registered capital of Nanjing Zhongbei and Nanjing Public Utilities Proprietary Holding (Group) Company Limited (南京公用控股(集團)有限公司) which owns an interest of 5.81% of the registered capital of Nanjing Zhongbei.

Nanjing Zhongbei has nominated Zhao Wen (趙文) and Zhu De Xiang (朱德祥) as Directors. Both of them are non-executive Directors and they do not involve in the daily management of the Company.

As at the Latest Practicable Date, none of the shareholders of Nanjing Zhongbei has undertaken not to dispose of their respective shareholdings in Nanjing Zhongbei. Nanjing Zhongbei has undertaken to the Company and the Stock Exchange that, during the Lock-up Period, it will not, save as provided in Rule 13.18 of the GEM Listing Rules, (i) dispose of (nor enter into any agreement to dispose of) nor permit the registered holder to dispose of (or to enter into any agreement to dispose of) any of its equity interest in the Company; or (ii) otherwise create (nor enter into any agreement to create) nor permit the registered holder to create (or to enter into any agreement to create) any options, rights, interests or encumbrances in respect of any such interest.

None of the Directors and members of the senior management of the Company had any interest in Nanjing Zhongbei as at the Latest Practicable Date.

3. Huadong Technology is a joint stock limited liability company established in the PRC on 8 January 1993 and its A shares commenced listing on the Shenzhen Stock Exchange on 20 May 1997. It is principally engaged in the business of the manufacture and sale of electronic vacuum device, lighting device, display device, new generation of electronic device and electronic materials and crystal device and provision of energy resources. As the Company is principally engaged in the provision and operation of video security system solutions, the business of Huadong Technology does not compete with that of the Company.

According to the 2003 annual report of Huadong Technology, the shareholder of Huadong Technology which holds an interest of 5% or more is Nanjing Huadong Electronic Group Company (南京華東電子集團公司) which owns an interest of 45.20% of the registered capital of Huadong Technology.

According to the 2003 annual report of Huadong Technology, Nanjing Huadong Electronic Group Company (南京華東電子集團公司) is a State-owned enterprise established in the PRC on 30 May 1991. It is principally engaged in the business of manufacture and sale of fluorescent powder; lightings, medical electronics, solar energy water heater, modules, devices of integrated systems and fire prevention products. It does not engage in any business which competes with the business of the Company.

SUMMARY OF THE PROSPECTUS

Huadong Technology has nominated Zhao Jing Cheng (趙竟成) and Zhang Yin Qian (張銀千) as Directors. Both of them are non-executive Directors and they do not involve in the daily management of the Company.

As at the Latest Practicable Date, none of the shareholders of Huadong Technology has undertaken not to dispose of their respective shareholdings in Huadong Technology. Huadong Technology has undertaken to the Company and the Stock Exchange that, during the Lock-up Period, it will not, save as provided in Rule 13.18 of the GEM Listing Rules, (i) dispose of (nor enter into any agreement to dispose of) nor permit the registered holder to dispose of (or to enter into any agreement to dispose of) any of its equity interest in the Company; or (ii) otherwise create (nor enter into any agreement to create) nor permit the registered holder to create (or to enter into any agreement to create) any options, rights, interests or encumbrances in respect of any such interest.

None of the Directors and members of the senior management of the Company had any interest in Huadong Technology as at the Latest Practicable Date.

4. Sample Commerce City is a limited liability company established in the PRC on 1 December 1996. Its scope of business is the sale of computers, computer accessories and consumables materials, electronic products and communication equipment (excluding ground reception unit for satellite), household appliances; venue letting; sale of merchandise, office appliances, ironmongery alternating current power, mechanical products, electrical appliances and machinery, building materials; design, production of and agent service for press and magazine, printed advertisement and gift advertisement; goods and accessories, warehousing, loading and unloading and transportation (applicable for operation by branches only).

Sample Commerce City has not appointed and does not intend to appoint any representatives to the Board or involve in the management of the Company.

For background of Sample Group, please refer to Note 1 above.

Liao Qiong (廖瓊) is directly interested in 3.58% equity interest in Sample Group which in turn will be directly interested in approximately 27.91% of the registered capital of the Company immediately after the completion of the Placing (without taking into account any Shares which may fall to be issued upon the exercise of any options granted under the Share Option Scheme). She is also interested in 5% equity interest in Sample Commerce City which in turn will be directly interested in approximately 2.56% of the Company immediately after the completion of the Placing (without taking into account any Shares which may fall to be issued upon the exercise of any options granted under the Share Option Scheme). She is also the finance department manager of Sample Group. She does not involve in the day-to-day management and the daily operation of the Company.

Sample Commerce City has undertaken to the Company and the Stock Exchange that, during the Lock-up Period, it will not, save as provided in Rule 13.18 of the GEM Listing Rules, (i) dispose of (nor enter into any agreement to dispose of) nor permit the registered holder to dispose of (or to enter into any agreement to dispose of) any of its equity interest in the Company; or (ii) otherwise create (nor enter into any agreement to create) nor permit the registered holder to create (or to enter into any agreement to create) any options, rights, interests or encumbrances in respect of any such interest.

Sample Group and Liao Qiong (廖瓊) are interested in 95% and 5% respectively of the registered capital of Sample Commerce City. Each of the shareholders of Sample Commerce City has undertaken to the Company and the Stock Exchange that it/she will not dispose of (nor enter into any agreement to dispose of) any of its/her equity interest in Sample Commerce City for a period of 12 months from the Listing Date.

5. Nanjing Daily was registered as a State-owned enterprise in the PRC on 13 May 1996. Its scope of business is newspaper printing, publication and issue; printing, plate making, advertising and other business activities.

Pursuant to the Provisional Measures on the Administration of the Reduction of the State-owned Shares for Raising Public Security Funds (減持國有股募集社會保障資金管理暫行辦法) promulgated by the State Council on 12 June 2001, holders of state-owned shares of a joint stock limited company in the PRC shall offer for sale such number of state-owned shares which is equivalent to 10% of the funds to be raised under the initial public offering of the joint stock limited company. Accordingly, the 900,000 State-owned Shares originally held by Nanjing Daily were

SUMMARY OF THE PROSPECTUS

transferred to the Vendor; which will be converted to 900,000 H Shares and are offered for sale at the Placing Price under the Placing. Such H Shares will rank pari passu with the New H Shares in all respects. The proceeds from the sale of the Sale H Shares will be remitted to the National Social Security Fund (全國社會保障基金). The PRC legal advisers to the Company advise that both CSRC and SASAC have no objection to the above arrangement in relation to the Domestic Shares held by the Vendor in the Company.

Nanjing Daily had not appointed any representatives to the Board or involved in the management of the Company.

Tian Tao (田濤), the legal representative of Nanjing Daily, is a Supervisor.

6. Sha Min (沙敏) is an executive Director and the chairman of the Company. He will be directly interested in approximately 0.7% of the registered capital of the Company immediately after the completion of the Placing (without taking into account any Shares which may fall to be issued upon the exercise of any options granted under the Share Option Scheme). He is also interested in approximately 24.42% of the registered capital of Sample Group which in turn will be directly interested in approximately 27.91% of the registered capital of the Company immediately after the completion of the Placing (without taking into account any Shares which may fall to be issued upon the exercise of any options granted under the Share Option Scheme). Accordingly, the attributable interest of Sha Min (沙敏) in the Company through Sample Group will be approximately 6.82%. His total shareholding interest in the Company (including direct and attributable interests) will be approximately 7.52% immediately after the completion of the Placing (without taking into account any Shares which may fall to be issued upon the exercise of any options granted under the Share Option Scheme).

Sha Min (沙敏) has undertaken to the Company and the Stock Exchange that, during the Lock-up Period, he will not, save as provided in Rule 13.18 of the GEM Listing Rules, (i) dispose of (nor enter into any agreement to dispose of) nor permit the registered holder to dispose of (or to enter into any agreement to dispose of) any of his equity interest in the Company; or (ii) otherwise create (nor enter into any agreement to create) nor permit the registered holder to create (or to enter into any agreement to create) any options, rights, interests or encumbrances in respect of any such interest.

7. It refers to the total consideration paid by each entity to become a Shareholder.
8. Each of Sample Group, Nanjing Zhongbei, Huadong Technology, Sample Commerce City and Sha Min (沙敏), being an Initial Management Shareholder, has undertaken to the Company and the Stock Exchange that, during the Lock-up Period, it/he will not, save as provided in Rule 13.18 of the GEM Listing Rules, (i) dispose of (nor enter into any agreement to dispose of) nor permit the registered holder to dispose of (or to enter into any agreement to dispose of) any of its/his equity interest in its/his Relevant Securities; or (ii) otherwise create (nor enter into any agreement to create) nor permit the registered holder to create (or to enter into any agreement to create) any options, rights, interests or encumbrances in respect of any such interest.

The Initial Management Shareholders have also undertaken to the Company and the Stock Exchange that it/he will comply with the requirements of Rule 13.19 of the GEM Listing Rules in respect of its/his Relevant Securities (including in the event of the creation of any charge or pledge over a direct or indirect interest in the Relevant Securities or the disposal of or the intention to dispose of its/his Relevant Securities pursuant to such charge or pledge, the Company must be informed immediately of such interest and the number of securities affected).

Each of the Directors (including the non-executive Directors and the independent non-executive Directors) has undertaken to the Company, the Sponsor and the Stock Exchange that he will: (i) not approve and will procure the Company not to approve: (a) the transfer of any of the Domestic Shares owned by each of the Initial Management Shareholders; and (b) the registration of any such transfer with the Nanjing Administration for Industry and Commerce (南京市工商行政管理局), for a period of 12 months from the Listing Date; (ii) submit copies of the undertakings in favour of the Stock Exchange and the Company in relation to the restriction on disposal of the Domestic Shares given by the Initial Management Shareholders to the Nanjing Administration for Industry and Commerce (南京市工商行政管理局) for filing purpose; and (iii) request the Nanjing Administration for Industry and Commerce (南京市工商行政管理局): (a) to insert a note in the register of the Company's information maintained by the Nanjing Administration for Industry and Commerce (南京市工商行政管理局) stating that all the Domestic Shares held by the Initial Management Shareholders cannot be transferred; and (b) not to register any transfer of the Domestic Shares held by the Initial Management Shareholders for a period of 12 months from the Listing Date.

SUMMARY OF THE PROSPECTUS

DIVIDEND POLICY

The Directors presently do not intend to recommend the payment of any dividend by the Group in respect of the financial year ending 31 December 2004. The declaration and payment of future dividends will be at the discretion of the Board subject to the approval of the Shareholders at its annual general meetings and will depend upon, among other things, the Group's operations, capital requirements and surplus, general financial condition, contractual restrictions and such factors as the Board may deem relevant. The Directors expect that, in future, the interim and final dividends, if any, will be paid in October and May respectively of each year. The Board will declare dividend, if any, in RMB, with respect to the H Shares on a per Share basis and will pay dividend in Hong Kong dollars. If the Company does not have sufficient foreign exchange reserves to pay its Hong Kong dollars dividends, it intends to exchange the required Hong Kong dollars from authorised banks in PRC or through other means.

SUMMARY OF RISK FACTORS

The Directors consider that there are certain risks involved in the Group's business, which include those set out under the section headed "Risk factors" in this prospectus. These risks can be categorised into (1) risks relating to the Group, (2) risks relating to the industry, (3) risks relating to the PRC, (4) risks relating to the Placing, and (5) risk relating to certain representations in this prospectus, and are summarised as follows:

(1) Risks relating to the Group

- Reliance on major customers
- Non-recurring nature of income
- Prolonged credit terms granted to certain customers
- Reliance on key personnel
- Risk of expansion in rapidly changing market
- Research and development risks
- Risks of losing preferential tax treatment
- Reliance on bank borrowings
- No assurance of revenue
- Uncertainty in future expansion
- Payment of dividends
- Potential product liability

SUMMARY OF THE PROSPECTUS

(2) Risks relating to the industry

- Competition
- Protection of intellectual property
- Uncertainty in the growth of demand for the Group's video security system solutions in the PRC
- Changes in technology and product cycles

(3) Risks relating to the PRC

- Political structure, social and economic environment of the PRC
- Changes in the PRC tax laws and regulations
- Changes in the PRC foreign exchange regulations and exchange risk
- The PRC's accession to the WTO
- Uncertainties regarding interpretation and enforcement of PRC laws and regulations
- Different levels of shareholder protection
- Submission to arbitration

(4) Risks relating to the Placing

- No prior public market for the H Shares
- The liquidity and market price of H Shares may be volatile
- Possible future dilution of Shareholders' interest in the Company

(5) Risk relating to certain representations in this prospectus

- Actual use of proceeds may deviate from original intention

SUMMARY OF THE PROSPECTUS

REASONS FOR THE PLACING AND THE USE OF PROCEEDS

The net proceeds from the Placing of the New H Shares, after deducting related listing expenses and underwriting commission, are estimated to be approximately HK\$41.5 million based on the Placing Price of HK\$2.70 per H Share, being the lower limit of the indicative Placing Price range as set out in this prospectus. The Group presently intends to apply approximately HK\$21.0 million of such net proceeds in the R&D and upgrading of system solutions, construction of information platform and launching of new system solutions. Details and the breakdown of the usage of the net proceeds from the Placing of the New H Shares are set out as follows:

- Approximately HK\$11.4 million will be invested in the R&D and upgrading of system solutions, including:
 - (i) approximately HK\$9.1 million for the traffic monitoring and control sector
 - (ii) approximately HK\$2.3 million for the customs logistics monitoring sector
- Approximately HK\$6.0 million will be invested in the construction of information platform, including:
 - (i) approximately HK\$4.8 million for the traffic monitoring and control sector
 - (ii) approximately HK\$1.2 million for the customs logistics monitoring sector
- Approximately HK\$3.6 million will be invested in the launching of new system solutions, including:
 - (i) approximately HK\$2.9 million for the traffic monitoring and control sector
 - (ii) approximately HK\$0.7 million for the customs logistics monitoring sector
- Approximately HK\$9.0 million will be invested in the purchase of additional equipment and/or facilities for commercialisation of system solutions
- Approximately HK\$6.0 million will be invested in the expansion of sales and distribution network
- Approximately HK\$5.5 million will be used as general working capital

The Placing Price, which is expected to be determined on or before the Price Determination Date, is not expected to be lower than HK\$2.70 but will not be more than HK\$4.60 per H Share. In the event that the net proceeds from the Placing of the New H Shares are not sufficient to cover the abovementioned plans for the use of proceeds, the Group intends to finance the remaining funds required through various financing alternatives, including, utilising its internal resources, obtaining additional equity financing or debt financing or through a combination of those methods. The Directors consider that the net proceeds from the Placing of the New H Shares, together with the Group's internally generated funds, will be sufficient to finance the implementation of the business plans of the Group as stated under the section headed "Statement of business objectives" in this prospectus.

SUMMARY OF THE PROSPECTUS

Should the Placing Price be fixed at HK\$4.60 per H Share, being the upper limit of the indicative Placing Price range as set out in the prospectus, the additional net proceeds from the Placing of the New H Shares, after deducting related listing expenses and underwriting commission, are estimated to be approximately HK\$35.5 million and will be applied by the Group in the same manner and in the same proportion as shown above.

To the extent that the net proceeds from the Placing of the New H Shares are not immediately applied for the above purposes, it is the present intention of the Directors that such net proceeds will be placed on short-term deposits.

In the event that any part of the business plans of the Group does not materialise or proceed as planned, the Directors will evaluate the situation and may reallocate the intended funding to other business plans and/or to new projects of the Group and/or to hold such funding as short-term deposits so long as the Directors consider it to be in the best interests of the Group and the Shareholders taken as a whole. The Company will make an announcement and comply with other applicable requirements in accordance with the GEM Listing Rules if this occurs.

PLACING STATISTICS

	Based on the Placing Price of	
	HK\$2.70	HK\$4.60
Market capitalisation of the H Shares (<i>Note 1</i>)	HK\$55,080,000	HK\$93,840,000
Adjusted net tangible asset value per Share (<i>Note 2</i>)	RMB1.81	RMB2.39
	(approximately HK\$1.71)	(approximately HK\$2.25)

Notes:

1. The calculation of the market capitalisation is based on the Placing Price as stated above and 20,400,000 H Shares in issue immediately after the completion of the Placing (without taking into account any Shares which may fall to be issued upon the exercise of any options granted under the Share Option Scheme).
2. The adjusted net tangible asset value per Share has been arrived at after making the adjustments referred to in the paragraph headed "Adjusted net tangible assets" under the section headed "Financial information" in this prospectus and on the basis of a total of 64,500,000 Shares in issue immediately following the completion of the Placing (without taking into account any Shares which may fall to be issued upon the exercise of any options granted under the Share Option Scheme).

DEFINITIONS

In this prospectus, unless the context otherwise requires, the following expressions have the meanings set out below. Certain other terms are explained under the section headed "Glossary of technical terms" in this prospectus.

"Articles of Association"	the articles of association of the Company adopted by the Shareholders in general meeting on 24 April 2004
"Associate(s)"	has the meaning ascribed to it under the GEM Listing Rules
"Board of Directors" or "Board"	the board of Directors
"Business day"	any day on which the Stock Exchange is open for the business of dealing in securities
"CAGR"	compounded annual growth rate
"CCASS"	the Central Clearing and Settlement System established and operated by HKSCC
"CCID"	China Centre of Information Industry Development (中國電子信息產業發展研究院), an institution established as a legal person by, and under the supervision of the MII
"CCID Consulting"	CCID Consulting Company Limited (賽迪顧問股份有限公司), a joint stock limited company converted from CCID Information Consulting Company Limited and established in PRC under the Company Law on 15 March 2002
"CCID Data"	CCID Datasource Co., Ltd. (北京賽迪數據有限公司), a limited liability company established in PRC under the Company Law
"Chief Executive(s)"	has the meaning ascribed to it under the GEM Listing Rules
"Companies Ordinance"	the Companies Ordinance (Chapter 32 of the Laws of Hong Kong)
"Company" or "Sample Technology"	Nanjing Sample Technology Company Limited (南京三寶科技股份有限公司), the successor of Sample Computer Technology, a joint stock limited company established in the PRC on 29 December 2000 under the Company Law
"Company Law"	the Company Law of the PRC (中華人民共和國公司法), enacted by the Standing Committee of the Eighth NPC on 29 December 1993 and came into force on 1 July 1994, as amended, supplemented or otherwise modified from time to time

DEFINITIONS

“Connected person(s)”	has the meaning ascribed to it under the GEM Listing Rules
“CPY” or “Sponsor”	Core Pacific – Yamaichi Capital Limited, a deemed licensed corporation for types 1, 4, 6 and 9 regulated activities under the SFO, and the sponsor of the Placing
“CPY International” or “Lead Manager”	Core Pacific – Yamaichi International (H.K.) Limited, a deemed licensed corporation for types 1, 4, 6, 7 and 9 regulated activities under the SFO, and the lead manager of the Placing
“CSRC”	China Securities Regulatory Commission (中國證券監督管理委員會)
“Director(s)”	the director(s) of the Company (including executive director(s), non-executive director(s) and independent non-executive director(s) of the Company)
“Domestic Share(s)”	ordinary share(s) of nominal value of RMB1.00 each in the share capital of the Company which are subscribed for or credited as paid up in RMB
“EPZs”	Export Processing Zones, which are specially enclosed areas supervised by the General Administration for Customs
“Forward Looking Period”	the period from the Latest Practicable Date to 31 December 2006
“GEM”	the Growth Enterprise Market of the Stock Exchange
“GEM Listing Committee”	the listing sub-committee of the Stock Exchange with responsibility for GEM
“GEM Listing Rules”	the Rules Governing the Listing of Securities on GEM
“GEM website”	the Internet website operated by the Stock Exchange for GEM at www.hkgem.com
“Golden Dragon Software”	Nanjing Golden Dragon Software Company Limited (南京金龍軟件有限公司), a limited liability company established in the PRC on 7 November 2001, is owned as to 95% by the Company and 5% by Qi Tong Lin (祁同林)
“Gross Proceeds”	Placing Price multiply by the Placing Shares

DEFINITIONS

“Group”	the Company and its subsidiaries
“H Share(s)”	overseas listed foreign invested share(s) of a nominal value of RMB1.00 each in the registered share capital of the Company which are to be listed on the GEM and subscribed for and traded in Hong Kong dollars
“HK\$”	Hong Kong dollars, the lawful currency of Hong Kong
“HKIAC”	Hong Kong International Arbitration Centre
“HKSCC”	Hong Kong Securities Clearing Company Limited
“Hong Kong”	the Hong Kong Special Administrative Region of the PRC
“Huadong Electronics”	Nanjing Huadong Electronics Group Company Limited (南京華東電子集團股份有限公司), a joint stock limited liability company established in the PRC on 8 January 1993 and its A Shares commenced listing on the Shenzhen Stock Exchange on 20 May 1997. It changed its name to Huadong Technology on 9 November 2000
“Huadong Technology”	Nanjing Huadong Electronics Information & Technology Company Limited (南京華東電子信息科技股份有限公司), the successor of Huadong Electronics. It is one of the Promoters and Initial Management Shareholders. For further particulars of Huadong Electronics, please refer to the paragraph headed “Shareholding structure” under the section headed “General overview of the Group” in this prospectus
“Independent Third Party(ies)”	party(ies) which are not connected with any of the Promoters, Directors, Supervisors, Chief Executives, Substantial Shareholders or Management Shareholders of the Company or any of its subsidiaries or any of their respective associates
“Initial Management Shareholder(s)”	has the meaning ascribed to it under the GEM Listing Rules and in relation to the Company, refers to the Promoter(s) (other than Nanjing Daily), namely Sample Group, Nanjing Zhongbei, Huadong Technology, Sample Commerce City and Sha Min (沙敏)
“ISO”	International Organisation for Standardisation, a network of national standards institutes from 148 countries working in partnership with international organisations, governments, industry, business and consumer representatives. It is responsible for creating international standards in many areas and acts as a bridge between public and private sectors

DEFINITIONS

“Latest Practicable Date”	27 May 2004, being the latest practicable date for ascertaining certain information in this prospectus prior to its publication
“Licence Agreement”	the licence agreement dated 1 January 2001 between Sample Group and the Company regarding the use of the domain name “www.samples.com.cn” and the trademarks “  ” and “神保”, particulars of which are set out in the paragraph headed “Exempted continuing connected transactions” in the section headed “Substantial Shareholders and Initial Management Shareholders” in this prospectus
“Listing Date”	the date on which the dealings of H Shares first commence on GEM
“Lock-up Period”	the period commencing on the date of this prospectus and ending on the date which is 12 months from the Listing Date (both dates inclusive)
“Macau”	the Macau Special Administrative Region of the PRC
“Management Shareholder(s)”	has the meaning ascribed to it under the GEM Listing Rules
“Mandatory Provisions”	the Mandatory Provisions for Articles of Association of Companies to be Listed Overseas (到境外上市公司章程必備條款) (as amended and supplemented from time to time), for inclusion in the articles of association of companies incorporated in the PRC to be listed overseas, which were promulgated by the former Securities Commission of the State Council (國務院證券委員會) and the former State Commission for Restructuring the Economic System (國家經濟改革委員會) of the PRC on 27 August 1994
“MIIT”	Ministry of Information Industry of the PRC (中國信息產業部)
“MOF”	Ministry of Finance of the PRC (中國財政部)
“Mr. Chang” or “Chang Yong (常勇)”	Chang Yong (常勇), a Director who is also interested in 4.67% of the registered capital of Sample Group
“Mr. Guo” or “Guo Ya Jun (郭亞軍)”	Guo Ya Jun (郭亞軍), a Director who is also interested in 2.27% of the registered capital of Sample Group
“Mr. Sun” or “Sun Huai Dong (孫懷東)”	Sun Huai Dong (孫懷東), a Supervisor who is also interested in 10.15% of the registered capital of Sample Group
“Ms. Du” or “Du Jin (杜瑾)”	Du Jin (杜瑾), a Supervisor who is also interested in 0.36% of the registered capital of Sample Group

DEFINITIONS

“Nanjing Daily”	Nanjing Daily Newspaper Office (南京日報社), a State-owned enterprise established in the PRC on 13 May 1996. Pursuant to the Provisional Measures on the Administration of the Reduction of the State-owned Shares for Raising Public Security Funds (減持國有股籌集社會保障資金管理暫行辦法) promulgated by the State Council on 12 June 2001, the 900,000 State-owned Shares originally held by Nanjing Daily were transferred to the Vendor which is offering such Domestic Shares, to be converted to 900,000 H Shares, for sale under the Placing
“Nanjing Zhongbei”	Nanjing Zhongbei (Group) Company Limited (南京中北(集團)股份有限公司), a joint stock limited liability company established in the PRC on 10 July 1992. Its A Shares commenced listing on the Shenzhen Stock Exchange on 6 August 1996 and it is one of the Promoters and Initial Management Shareholders. For further particulars of Nanjing Zhongbei, please refer to the paragraph headed “Shareholding structure” under the section headed “General overview of the Group” in this prospectus
“New H Share(s)”	the 19,500,000 new H Share(s) being offered by the Company for subscription at the Placing Price under the Placing
“NPC” or “National People’s Congress”	the National People’s Congress (全國人民代表大會)
“Option Agreement”	the trademark transfer option agreement dated 1 August 2003 between Sample Group and the Company regarding the transfer of the trademark “神保”, particulars of which are set out in the paragraph headed “Exempted continuing connected transactions” in the section headed “Substantial Shareholders and Initial Management Shareholders” in this prospectus
“PBOC”	People’s Bank of China (中國人民銀行)
“Placing”	the conditional placing by the Company through the Placing Underwriters of the Placing Shares at the Placing Price with professional, institutional and other investors as set out under the section headed “Structure and conditions of the Placing” in this prospectus
“Placing and Underwriting Agreement”	the conditional placing and underwriting agreement dated 2 June 2004 and entered into between the Company, the executive Directors, the Initial Management Shareholders, the Sponsor, CPY International, the Placing Underwriters and the Vendor, further details of which are set out under the section headed “Underwriting” in this prospectus

DEFINITIONS

“Placing Price”	the price per Placing Share (exclusive of brokerage, the Stock Exchange trading fee, SFC transaction levy and investor compensation levy) to be determined as set out under the section headed “Structure and conditions of the Placing” in this prospectus
“Placing Share(s)”	the New H Share(s) and Sale H Share(s) being offered under the Placing at the Placing Price
“Placing Underwriters”	the underwriters whose name appear in the paragraph headed “Placing Underwriters” under the section headed “Underwriting”
“PRC” or “China”	the People’s Republic of China and for the purpose of this prospectus, excludes Hong Kong, Macau and Taiwan
“PRC government” or “State”	the central government of the PRC including all governmental subdivisions (including provincial, municipal and other regional or local government entities) and instrumentalities thereof
“Price Determination Date”	the date on which the Placing Price will be fixed, which is expected to be on or before 3 June 2004
“Promoter(s)”	the promoter(s) of the Company, namely Sample Group, Nanjing Zhongbei, Huadong Technology, Sample Commerce City, Nanjing Daily and Sha Min (沙敏)
“Relevant Securities”	has the meaning as defined in Rule 13.15 of the GEM Listing Rules
“RMB”	Renminbi, the lawful currency of the PRC
“SAFE”	State Administration of Foreign Exchange (國家外匯管理局)
“Sale H Shares”	the 900,000 Domestic Shares held by the Vendor to be converted into 900,000 H Shares pursuant to the Provisional Measures on the Administration of the Reduction of the State-owned Shares for Raising Public Security Funds (減持國有股募集社會保障資金管理暫行辦法) which will be offered for sale at the Placing Price under the Placing
“Sample Commerce City”	Nanjing Sample Technology Commerce City Company Limited (南京三寶科技商城有限公司), a limited liability company incorporated in the PRC on 1 December 1996, is one of the Promoters and Initial Management Shareholders. For further particulars of Sample Commerce City, please refer to the paragraph headed “Shareholding structure” under the section headed “General overview of the Group” in this prospectus

DEFINITIONS

“Sample Computer Technology”	Nanjing Sample Computer Technology Company Limited (南京三寶計算機科技有限公司), the predecessor of the Company. It changed its name to the Company on 29 December 2000
“Sample Group”	Nanjing Sample Technology Group Company Limited (南京三寶科技集團有限公司), formerly known as Sample Industry, is one of the Promoters and Initial Management Shareholders. For further particulars of Sample Group, please refer to the paragraph headed “Shareholding structure” under the section headed “General overview of the Group” in this prospectus
“Sample Industry”	Nanjing Sample Technology Industry Company Limited (南京三寶科技實業有限公司), a limited liability company established in the PRC on 12 June 1993 which changed its name to Sample Group on 20 August 2002
“Sample Information System Engineering”	Nanjing Sample Information System Engineering Company Limited (南京三寶信息系統工程有限公司), a limited liability company established in the PRC on 11 March 2000 and is owned as to 80% by the Company and 20% by Sample Group.
“Sample System”	Nanjing Sample Computer System Engineering Company Limited (南京三寶計算機系統工程有限公司), a limited liability company established in the PRC on 30 December 1997 which changed its name to Sample Computer Technology (南京三寶計算機科技有限公司) on 28 February 2000 and to the current name of the Company on 29 December 2000
“SARS”	an acronym for Severe Acute Respiratory Syndrome
“SASAC”	State-owned Assets Supervision and Administration Commission of the State Council (國務院國有資產監督管理委員會)
“Securities Law”	the Securities Law of the PRC (中華人民共和國證券法) enacted by the Standing Committee of the NPC on 29 December 1998 and which became effective on 1 July 1999, as amended, supplemented and modified from time to time
“SFC”	Securities and Futures Commission of Hong Kong
“SFO”	the Securities and Futures Ordinance (Chapter 571 of the Laws of Hong Kong)
“Sha Min (沙敏)” or “Mr. Sha”	Sha Min (沙敏) is one of the Directors, Promoters and Initial Management Shareholders. For further particulars of Sha Min (沙敏), please refer to the paragraph headed “Shareholding structure” under the section headed “General overview of the Group” in this prospectus
“Share Option Scheme”	the share option scheme conditionally approved and adopted by the Company on 24 April 2004, the principal terms of which are summarised in the paragraph headed “Summary of the terms of the Share Option Scheme” in Appendix VII to this prospectus

DEFINITIONS

“Shareholder(s)”	shareholder(s) of the Company
“Share(s)”	Domestic Share(s) and/or H Share(s), as the case may be
“Sino-Foreign Joint Venture Law”	Sino-Foreign Joint Venture Law (中外合資經營企業法), issued on 1 July 1979 by the NPC, as amended, supplemented or otherwise modified from time to time
“Special Regulations”	the Special Regulations of the State Council on the Overseas Offering and Listing of Shares by Joint Stock Limited Companies (國務院關於股份有限公司境外募集股份及上市的特別規定), issued by the State Council on 4 August 1994, as amended, supplemented or otherwise modified from time to time
“State Council”	State Council of the PRC (中國國務院)
“State-owned Shares”	900,000 Domestic Shares of RMB1.00 each, representing 2% of the registered capital of the Company immediately before the completion of the Placing, which will be converted to 900,000 H Shares and offered for sale by the Vendor at the Placing Price under the Placing pursuant to the Provisional Measures on the Administration of the Reduction of the State-owned Shares for Raising Public Security Funds (減持國有股籌集社會保障資金管理暫行辦法) promulgated by the State Council on 12 June 2001
“State Torch Program”	國家級火炬計劃, a guiding program approved by the State Council in August 1988 to develop high and new technology industries in the PRC. This program is implemented by the State Science and Technology Commission (now known as the Ministry of Science and Technology of the PRC (中國人民共和國科學技術部))
“Stock Exchange”	The Stock Exchange of Hong Kong Limited
“subsidiaries”	has the meaning ascribed to it under the GEM Listing Rules
“Substantial Shareholder(s)”	has the meaning ascribed to it under the GEM Listing Rules
“Supervisor(s)”	the member(s) of the supervisory committee of the Company
“Supplemental Agreement”	the supplemental agreement to the Licence Agreement dated 2 April 2004 between Sample Group and the Company, particulars of which are set out in the paragraph headed “Exempted continuing connected transactions” in the section headed “Substantial Shareholders and Initial Management Shareholders” in this prospectus
“Takeovers Code”	the Code on Takeovers and Mergers issued by the Securities and Futures Commission of Hong Kong, as amended, supplemented and otherwise modified from time to time

DEFINITIONS

“Track Record Period”	the period covering the three years ended 31 December 2003
“Transfer Option”	the option to acquire the trademark “神保” pursuant to the Option Agreement, particulars of which are set out in the paragraph headed “Exempted continuing connected transactions” in the section headed “Substantial Shareholders and Initial Management Shareholders” in this prospectus
“VAT”	value added tax
“Vendor”	National Council for Social Security Fund, the PRC (全國社會保障基金理事會), which is under the direct supervision of the State Council. Its principal function includes asset management of the social security fund of the PRC
“WTO”	World Trade Organisation
“US” or “United States”	United States of America
“US Exchange Act”	the United States Securities Exchange Act of 1934, as amended, and the rules and Regulation promulgated thereunder
“US Securities Act”	the US Securities Act of 1953, as amended
“US\$” or “US Dollars”	the lawful currency of the US
“sq.m.”	square metre(s)
“%”	per cent.

Unless otherwise specified in this prospectus, amounts denominated in RMB and US\$ have been translated, for the purpose of illustration only, into Hong Kong dollars as follows:

HK\$7.80 = US\$1.00

HK\$1.00 = RMB1.06

No representation is made by the Group that any amounts in RMB, US\$ or HK\$ could have been or could be converted at the above rate or at any other rates or at all.

In this prospectus, the English names of publications or documents, enterprises or government authorities established in, or citizens of the PRC are translations of their Chinese names and are included for identification purpose only. In the event of any inconsistency, the Chinese names shall prevail.

The contents at the various websites referred to in this prospectus do not form part of this prospectus.

GLOSSARY OF TECHNICAL TERMS

This glossary contains explanations of certain terms and definitions used in this prospectus in connection with the Group and its business. The terms and their meanings may not correspond to standard industry meanings or usage of those terms.

“CCD”	an acronym for Charge-Coupled Device, a light-sensitive electronic device built on semiconductor technology such as cameras and image scanners. Such device may stores and displays the data for an image in such a way that each pixel in the image is converted into an electrical charge
“CORBA”	an acronym for Common Object Request Broker Architecture, it is an architecture and specification for creating, distributing, and managing distributed program objects in a network. It allows programs at different locations and developed by different vendors to communicate in network through an “interface broker”
“CTGIS”	an acronym for City Traffic Geographic Information Systems, which is developed from the GIS system and is used for city traffic control
“FTP”	an acronym for File Transfer Protocol, a standard Internet protocol, is the simplest way to exchange files between computers on the Internet
“GIS”	an acronym for Geographic Information Systems, which enables visualization of the geographic aspects of a body of data. GIS allows the query or analysis of a relational database and receipt of results in the form of some kind of map
“GPS”	an acronym for Global Positioning System, a worldwide satellite navigational system formed by multiple satellite orbiting the earth. It allows user with ground receivers to pinpoint their geographic location
“Intelligent Construction”	Pursuant to the Notice published by the Construction Management Secretary of the Ministry of Construction of the PRC in relation to the Standards of the qualification and gradings of the Construction Enterprises (建築部建築管理司關於印發《建築業企業資質等級標準》的通知) issued by the Construction Management Secretary of the Ministry of Construction of the PRC (中華人民共和國建築部建築管理司), intelligent construction works include computer management system projects, construction facilities self control system projects, security surveillance and alarming system projects, intelligent card system projects, communication system projects, satellite and public television system projects, car park management projects, integrated wiring system projects, computer network system projects, broadcasting system projects, conference system projects, VOD system projects, intelligent small district integrated

GLOSSARY OF TECHNICAL TERMS

property management system projects, video conference system projects, large display system projects, intelligent lighting and audio control system projects, fire alarming system projects and computer co-location projects

“Internet”	an international network of interconnected, separately administered public and private networks through which information providers can make information available to users/customers globally
“IT”	an acronym for Information Technology, a common title for the entire spectrum of technologies for information processing including software, hardware, communication technologies and related services
“ITS”	an acronym for Intelligence Transportation System, a combined application of information technology, digital transmission technology computer system and other technologies to effect transportation information management providing traffic information on display panels located on roads
“LAN”	an acronym for Local Area Network, a communication network that serves users within a confined geographical area
“PC”	an acronym for Personal Computer, a micro-computer for personal use
“platform”	with reference to computers, a platform is an underlying information system on which higher level application can be operated
“R&D”	an acronym for Research and Development
“RDB”	an acronym for Relational DataBase, it is a fast, portable, relational database management system without arbitrary limits, (other than memory and processor speed) that runs under, and interacts with, the UNIX operating system
“RFID”	an acronym for Radio Frequency Identification, a technology that incorporates the use of electromagnetic or electrostatic to uniquely identify an object, animal, or person. RFID does not require direct contact or line-of-sight scanning
“SI”	an acronym for System Integration, which is the design, installation and testing of application systems and related services based on customers' requirements

GLOSSARY OF TECHNICAL TERMS

“system solutions”	video security system solutions utilising video and radio capability to facilitate the protection of public security and enforcement of public security measures/laws/regulations
“UNIX”	an operating system as an interactive time-sharing system
“video security products”	products utilising video and radio capability to facilitate the protection of public security and enforcement of public security measures/laws/regulations
“VOD”	an acronym for Video on Demand, a multimedia application with which a user can access motion or still video, which may be available as public or private services
“WAN”	an acronym for Wide Area Network, a communication network that covers a wide geographical area
“web”	a system of Internet servers that support specifically formatted documents which are formatted in the hypertext mark-up language
“XML”	an acronym for Extensible Markup Language, a communications specification on the Internet

RISK FACTORS

Prospective investors should carefully consider all of the information set out in this prospectus and, in particular, the following risk factors and special considerations associated with the Group before making any investment decision in relation to the Placing Shares.

RISKS RELATING TO THE GROUP

Reliance on major customers

A significant portion of the Group's revenue has been and may continue to be derived from a limited number of customers. For each of the three years ended 31 December 2003, the number of customers of the Group's video security system solutions were 58, 51 and 51 respectively. The Directors believe that since the Group has targeted on the PRC government as one of its major customers, with the increase in demand and investment of video security information system and the expansion of distribution network by the PRC government during the Track Record Period, the sales derived from its five largest customers increased accordingly. For each of the three years ended 31 December 2003, the Group's sales to its largest customer in the respective years accounted for approximately 9.7%, 23.7% and 14.7% respectively of the Group's total turnover, and its sales to its five largest customers together accounted for approximately 34.0%, 53.4% and 44.5% respectively of the Group's total turnover for the respective years. For the year ended 31 December 2003, the largest customer of the Group in the traffic monitoring and control sector and the customs logistics monitoring sector is the Traffic Police Headquarters of the Public Security Bureau of Shandong Province (山東省公安廳交通警察總隊) and the Procurement and Supply Centre of the General Administration of China Customs (海關總署物資裝備供應中心) respectively, which are both PRC government bureaus. The Traffic Police Headquarters of the Public Security Bureau of Shandong Province (山東省公安廳交通警察總隊) is also the largest customer of the Group for each of the two years ended 31 December 2003. The Group does not have any long-term sale agreement with its customers and its future revenue may be uncertain. In the event that the Group fails to secure new business from its existing customers or is unable to find new customers, the Group's profit may be adversely affected.

Non-recurring nature of income

The Group derives most of its revenue from government projects in which PRC government authorities usually engage the Group to provide system solutions and services in respect of their projects. Accordingly, most of the Group's revenues are non-recurring and not long-term in nature and there is no guarantee that the PRC government authorities will continue to engage the Group to provide system solutions and services for their projects in the future. In the event that the Group is unable to maintain business relationship with the PRC government authorities, the Group's profitability may be adversely affected.

Prolonged credit terms granted to certain customers

The Group's general credit terms granted to its customers normally range from 90 to 180 days. In determining the length of credit terms granted to a specific customer, the Group considers various factors such as the reputation of the customer, length of its business relationship with the Group and its past payment records. During each of the three years ended 31 December 2003, the Group's trade receivables turnover period was approximately 179 days, 181 days and 174 days respectively. The percentage of trade receivables to total turnover of the Group for each of the three years ended 31 December 2003 were approximately 48.9%, 49.5% and 47.6% respectively. As at 31 December 2003, the trade receivables of the Group amounted to approximately RMB29.4 million, representing approximately 26.4% of the total current assets of the Group and 39.3% of the net assets of the Group respectively.

RISK FACTORS

The Group grants prolonged credit terms to certain customers, namely the Traffic Police Headquarters of the Public Security Bureau of Shandong Province (山東省公安廳交通警察總隊) and the Procurement and Supply Centre of the General Administration of China Customs (海關總署物資裝備供應中心), which are both PRC government authorities. As at 31 December 2003, the trade receivables due from the Traffic Police Headquarters of the Public Bureau of Shandong Province (山東省公安廳交通警察總隊) were approximately RMB0.4 million, representing approximately 4.5% of the turnover from that customer. As at 31 December 2003, the trade receivables due from the Procurement and Supply Centre of the General Administration of China Customs (海關總署物資裝備供應中心) was approximately RMB2.5 million, representing approximately 64.1% of the turnover from that customer.

The Group provides the above two customers with prolonged credit terms because the Directors believe that their default risks are lower than those of private companies and they have maintained established business relationship with the Group. However, there is no guarantee that these two customers will settle their payment within the prolonged credit period. If either or both of these two customers delay or default on any payments, the Group will be required to make provision or write off the relevant trade receivables and may adversely affect the Group's financial position and profitability.

Reliance on key personnel

The success of the Group is, to a certain extent, built upon the expertise and experience of its key personnel such as its executive Directors, namely, Sha Min (沙敏), Chang Yong (常勇) and Guo Ya Jun (郭亞軍). Sha Min (沙敏), the chairman of the Company, has a number of years of experience in the video security industry in the PRC and he is responsible for the strategic planning and the overall development of the Group. Chang Yong (常勇), who is also the general manager of the Company, is responsible for the overall operation of the Group. Guo Ya Jun (郭亞軍), who is also the deputy general manager and financial controller of the Company, is responsible for the accounting and financial aspects of the Group. The Company has entered into a service contract with each of the executive Directors for an initial term of three years, but there can be no assurance that the Group will be able to retain all existing personnel or to attract and recruit other capable personnel should any of them leave the Group. In the event that any key personnel cease to serve the Group for whatever reasons, the Group's operations may be adversely affected.

Risk of expansion in rapidly changing market

The market in which the Group operates is characterised by rapidly changing technology, evolving industry standards, frequent development and enhancement of new service and product announcements, introductions and changing customer demands. Accordingly, the Group's future success will depend on its ability to adapt to rapidly changing technologies, to adapt its services to evolving industry standards and continually improve the performance, features and reliability of its products and services in response to competitive service and product offerings and evolving demands of the market place.

If the Group fails to keep up with the latest technology, it may be unable to meet the latest demand from its customers thereby giving rise to a decline in the market competitiveness of its products and the Group's operations may thereby be adversely affected.

RISK FACTORS

Research and development risks

For each of the three years ended 31 December 2003, the R&D costs of the Group amounted to approximately RMB877,000, RMB1.7 million and RMB2.2 million respectively. For each of the three years ended 31 December 2003, the R&D costs spent by the Group were approximately 2.7%, 2.7% and 3.6% of the Group's total turnover respectively. The Directors presently intend to apply approximately HK\$11.4 million of the net proceeds from the Placing of the New H Shares (approximately HK\$41.5 million based on the Placing Price of HK\$2.70 per H Share, being the lower limit of the indicative Placing Price range as set out in this prospectus) during the Forward Looking Period for R&D and upgrading of system solutions, out of which approximately HK\$9.1 million and HK\$2.3 million are intended to be invested in the traffic monitoring and control sector and the customs logistics monitoring sector respectively. The Directors also intend to apply approximately HK\$6.0 million and HK\$3.6 million of the net proceeds from the Placing of the New Shares during the Forward Looking Period for the construction of information platform and launching of new system solutions that are successfully developed under the Group's R&D initiatives. The Group intends to spend an aggregate of approximately HK\$21.0 million during the Forward Looking Period in such R&D, information platform construction and launching activities for its system solutions.

Since the Group intends to increase its spending on R&D as compared to the past, there is no guarantee that the Group can successfully handle a significantly larger scale of R&D activities after the listing of the H Shares on GEM and the growth of the Group's turnover and profits in the future will heavily depend on the market performance of the new system solutions. In the event that the Group fails to develop any new system solutions or its system solutions do not receive targeted market acceptance as expected, the Group's business may be adversely affected. In particular, given the relatively larger scale of R&D activities that the Group intends to be engaged in, the Group's future business performance may also be gradually become more reliant on the R&D of new system solutions in order to maintain the Group's reputation and position in the market. Since such new system solutions have not been introduced to the market and their market recognition has not been proven, there is no guarantee that the new system solutions developed will generate the amount of revenue that the Directors expect. Any hindrance to the sales and marketing of such system solutions may also have an adverse effect on the Group's future profitability.

Risks of losing preferential tax treatment

According to the applicable PRC laws and regulations, the Group has to pay income tax at a standard rate of 33%. However, the Group is currently paying income tax at a preferential rate of 15% as a result of the favourable policy implemented by the PRC government towards High and New Technology Enterprises (高新技術企業). Although the Jiangsu Science and Technology Department (江蘇省科學技術廳) has identified the Company as a High and New Technology Enterprise (高新技術企業), there can be no assurance that the Group can continue to enjoy the same preferential tax treatment in the future. In the event that the PRC government changes its tax policy of supporting high and new technology development or the Company ceases to be recognised as a High and New Technology Enterprise (高新技術企業), the Group may have to pay income tax at the standard rate of 33%. The Group's performance and profitability may be adversely affected by any unfavourable changes, in part or in whole, of the preferential tax policy.

RISK FACTORS

Reliance on bank borrowings

During the Track Record Period, the Group's operations have been heavily financed by loans from banks. As at 30 April 2004, the Group had outstanding bank borrowings of approximately RMB30.0 million, out of which RMB15.0 million granted by the Industrial and Commercial Bank of China ("ICBC") was guaranteed (the "Guarantee") by Sample Group, a Shareholder. According to an undertaking given by ICBC dated 29 December 2003, ICBC undertook that the Guarantee would be released and substituted by guarantee in the form of the Company's credit upon listing of the H Shares on GEM. For each of the three years ended 31 December 2003, the gearing ratio (calculated as total debts divided by total assets) of the Group was approximately 42.2%, 31.0% and 29.4% respectively. If the Group shall default in the repayment of the bank loans, experience difficulties in obtaining a rollover or renewal of its bank loans on maturity or fail to generate sufficient cash flow to meet its operation expenditure, its operations and performance may be adversely affected.

No assurance of revenue

The Group was established in December 1997. Due to this relatively short operating history, it may be difficult to assess the Group's business and future prospects as compared to those with longer operating histories and track records.

The Group's past operating results and its current business model depend on revenues generated from various individual projects instead of recurring, long-term projects. There is no assurance that the Group will be able to continue to secure projects that generate revenue. Should the Group be unable to generate sufficient revenue from its business activities in the future, the results and financial position could be adversely affected.

Uncertainty in future expansion

The Group plans to expand its business in the forthcoming period. Such strategies may involve aggressive marketing and advertising campaigns and increase in investment in R&D. There can be no assurance that such plans will be successful in the future. In addition, the Group's expansion plan may place a significant strain on the Group's management, operation and financial resources. There can be no assurance that the management will be able to manage the future growth of the Group successfully. Should the Group's resources be inadequate to support its future expansion, the business and operations of the Group may be adversely affected.

Payment of dividends

The Directors presently do not intend to recommend the payment of any dividend by the Group in respect of the profit for the financial year ending 31 December 2004. No dividends have been declared by the Company and its subsidiaries during the Track Record Period, except for Sample Information System Engineering which paid a dividend of RMB1,608,000 in 2001, out of which approximately RMB691,000 was paid to its then minority owners. Investors should note that the level of dividend declared and paid by the Company and its subsidiaries for the year ended 31 December 2001 cannot be used as a reference for the dividend policy that will be adopted by the Company following the listing of the H Shares on GEM. Particulars of the dividend policy to be adopted by the Group following the listing of the H Shares on GEM are set out in the paragraph headed "Dividend policy" under the section headed "Financial information" in this prospectus. There is no assurance by the Directors that the Group will declare any dividend in the future.

RISK FACTORS

Potential product liability

Any defects in or errors of the Group's video security system solutions and services may adversely affect customers' operations or the performance of such system solutions and services, and as a result of which the Group may incur additional costs in rectifying the defects or defending any potential legal proceedings and claims from its customers. It may also affect the Group's relationship with such customers and the reputation of the Group. At present, the Group does not maintain any product liability insurance for the product sold by it. In addition, the Group may not be able to acquire an insurance policy to cover all the risks in connection with any product liability on commercially acceptable terms. Although no potential legal claims nor pending litigations against any member of the Group in connection with its video security system solutions and services were brought to the attention of the Group since its establishment, there can be no assurance that there will not be any product liability claims against the Group in the future.

RISKS RELATING TO THE INDUSTRY

Competition

Unlike developed countries such as U.S. and Germany, where the market for video security system solutions has become mature, the PRC's market for video security system solutions is still at a developing stage. Given that the State's policy of encouraging purchase from domestic producers, the Directors, to the best of their knowledge, are not aware that foreign competitors have been invited to provide video security system solutions or services to the PRC government authorities.

The Directors believe that the market of video security system solutions in which the Group is engaged will continue to grow in the coming years. The prospect and potential of this market will attract entry by companies with substantial capital and resources. Mergers and acquisitions of enterprises and consolidation of the industry may become a trend in the market. The environment in which the Group operates will become more competitive as a result. Competitors may offer similar system solutions and services at a price lower than those of the Group. In addition, price quotation of projects may also be lower due to intense competition. There is no guarantee that the projects undertaken by the Group in the future will maintain the present profit margin and a highly competitive environment may adversely affect the Group's profitability.

Protection of intellectual property

The Group's success depends on its ability to protect its proprietary software. At present, most of the Group's principal application software products have software copyright in the PRC. In the course of product development, the Group enters into confidentiality agreements with its staff and third parties to ensure that the Group's trade secrets and intellectual property will be put in strict confidentiality. Trade secrets include the quantities and price of products provided to the Group and the components and parts purchased by the Group. In respect of the Group's products, the design of the products, the components of the products and customisation made for its customers are covered by the confidentiality agreements as well. However, it may be difficult to prohibit competitors from infringing the copyrights of the Group's products. Infringement of its intellectual property rights may adversely affect the business and results of the Group.

RISK FACTORS

Uncertainty in the growth of demand for the Group's video security system solutions in the PRC

The progress of digitalisation in the two major sectors where the Group operates, i.e. the traffic monitoring and control sector and the customs logistics monitoring sector will, to a large extent, depend on the PRC government's future policy to invest and upgrade public utilities and infrastructure in the two sectors. The amount of expenditure allocated to these two sectors by the PRC government determines the overall market size for video security system solutions of the two sectors. There is no assurance that the PRC government will continue to increase its expenditure in these areas as it did in the past. If the PRC government reduces its investment in any of these areas or its policy is unfavourable to public investment, the demand for the Group's video security system solutions in the above sectors as a whole will be adversely affected.

The growth of the Group's business and revenue relies primarily upon the development of the traffic monitoring and control sector and the customs logistics monitoring sector in the PRC. Accordingly, should the PRC government's policy not be in favour of the development of the traffic monitoring and control sector and the customs logistics monitoring sector in the PRC, the growth of the Group's business may be adversely affected.

Changes in technology and product cycles

The provision of video security system solutions by the Group is subject to the risks relating to rapid technology change and short product life cycle in the technology industry as advanced versions of IT products are constantly being introduced to the market at a rapid pace. The demand for IT products and services are also subject to business cycles which may rise or fall along with the overall economic and business environment in the PRC. The Group's business cycle depends on the PRC government's investment in ITS. To the best of the Directors' knowledge, the PRC government will adjust and control its budget and expenditure in ITS in accordance with the overall economic development of the PRC. Investors should be aware that the Group's future success may be dependent upon its quick response to technology and product life cycles so that the Group is able to offer products and services to meet the changing demands of its customers. If the Group is unable to respond promptly to market changes, it may adversely affect its future development.

RISKS RELATING TO THE PRC

Political structure, social and economic environment of the PRC

Prior to the adoption of reform and open-door policies in 1978, China was primarily a planned economy. Since then, the PRC government has undergone various reforms in its economic system and government structure. These reforms have resulted in significant economic growth and social progress. The Directors believe that those reforms relating to China's political, economic and social conditions, laws, regulations and policies will have a positive effect on the Group's overall and long-term development. However, there is no assurance that these reforms will not adversely affect the Group's current or future business or profitability.

Changes in the PRC tax laws and regulations

Various tax reform policies have been implemented in the PRC in recent years. Moreover, there is no assurance that the existing PRC tax laws and regulations will not be revised or amended, or that new laws and regulations will not be introduced in the future. Should there be any change in the PRC tax policies or regulations, the Group's profitability may be adversely affected.

RISK FACTORS

Changes in the PRC foreign exchange regulations and exchange risk

The PRC government imposes control over the convertibility of RMB into foreign currencies. With effect from 1 January 1994, the PRC government implemented a unified floating exchange rate system based on market supply and demand. Under the new system, the PBOC publishes the PBOC exchange rate based on the previous day's dealings in the interbank foreign exchange market. Foreign currency designated banks use the exchange rate published by the PBOC as a basis and decide a rate of its own, which is within the floating range specified by the PBOC, to enter into foreign exchange sales and purchase transactions with customers. Although the new regulations have provided for greater liquidity of RMB, it is still not a freely convertible currency. Foreign exchange transactions under the capital account, including principal payments in respect of foreign currency-denominated obligations, continue to be subject to limitations and require the prior approval of the SAFE. These limitations could affect the Group's ability to obtain foreign exchange through debt financing, or to obtain foreign exchange for capital expenditures or dividend payments to the holders of H Shares.

Under the existing foreign exchange regulations in the PRC, following the completion of the Placing, the Group may undertake current account foreign exchange transactions, including the payment of dividends, without prior approval from the SAFE by producing relevant documents evidencing such transactions, provided that they are processed through PRC banks licensed to engage in foreign exchange transactions. The value of the RMB may be influenced by factors such as changes in the PRC government's policies, the PRC's domestic and international economic and political developments, as well as the supply and demand in the local market. Since 1994, the official exchange rate for the conversion of RMB to US dollars has generally been stable, and the RMB has appreciated slightly against the US dollars. However, there can be no assurance that the value of the RMB will continue to remain stable against the US dollars or any other foreign currency. As the Group does not currently sell its products outside the PRC, a devaluation of the RMB may not have a negative impact on the Group's overall operations. However, any devaluation of the RMB may adversely affect the value of, and dividends payable on, the H Shares in foreign currency terms since the Company receives its revenues and expresses its profit in RMB.

The PRC's accession to the WTO

Following the accession of the PRC to the WTO, the PRC is required to reduce the import tariff and gradually relax or abolish certain tariff restrictions on foreign IT manufacturers. The lowering or removal of the import tariff barriers by the PRC government will likely result in increased competition in the PRC information service market from foreign competitors. These foreign competitors may have certain advantages over the Company including greater financial and technical resources, better brand recognition and more established relationships in the relevant market. There is no assurance that the Group's business results will not be adversely affected by such increased competition from the foreign competitors.

Uncertainties regarding interpretation and enforcement of PRC laws and regulations

The PRC legal system is based on statutory law. Under this system, prior court decisions may be cited as persuasive authority but do not have binding precedential effect. Since 1979, the PRC government has been developing a comprehensive system of commercial laws and considerable progress has been made in the promulgation of laws and regulations dealing with economic matters, such as corporate organisation and governance, foreign investment, commerce, taxation and trade. As these laws, regulations and legal requirements are relatively new, with a limited volume of published cases and judicial interpretations and the non-binding nature of prior court decisions, the interpretation and enforcement of these laws, regulations and legal requirements involve some uncertainty.

RISK FACTORS

Different levels of shareholder protection

As all of the Group's business is conducted in the PRC, its operations are governed principally by the laws of the PRC. As a PRC company offering and listing its shares outside the PRC, the Group is subject to the Special Regulations and the Mandatory Provisions. The Mandatory Provisions contain certain provisions that are required to be included in the articles of association of PRC companies to be listed abroad and are intended to regulate the internal affairs of those companies.

The Company Law and the Special Regulations, in general, and provisions for the protection of shareholders' rights and access to information, in particular, are less developed than those applicable to companies incorporated in Hong Kong, the United Kingdom, the United States and other economically developed countries or regions. The Company Law is different in certain important aspects from the company laws in the United States, Hong Kong and other common law countries or regions, particularly with regard to investor protection, including areas such as derivative actions by minority shareholders and other minority protections, restrictions on directors, financial disclosure, variations of class rights, procedures at general meetings and payments of dividends.

The limited nature of investor protection under the Company Law is compensated for, to a certain extent, by the introduction of the Mandatory Provisions and certain additional requirements that are imposed by the GEM Listing Rules with a view to reducing the scope of differences between Hong Kong company law and the Company Law. The Mandatory Provisions and those additional requirements must be included in the articles of association of all PRC companies applying to be listed in Hong Kong. The Articles of Association have incorporated the provisions required by the Mandatory Provisions and the GEM Listing Rules. Despite the incorporation of those provisions, there can be no assurance that investors will enjoy the protection that they may be entitled to in other jurisdictions.

Submission to arbitration

The Articles of Association require a holder of H Shares having a claim against or a dispute with the Company, a Director, a Supervisor or a manager or officer of the Company or a holder of the Company's Shares relating to any rights or obligations conferred or imposed by the Articles of Association, the Company Law and other PRC laws or administrative regulations and relating to the Company's affairs, to submit the dispute or claim to the China International Economic and Trade Arbitration Commission or to the Hong Kong International Arbitration Centre for arbitration. The Articles of Association further provide that the arbitration award shall be final and binding on all parties.

The PRC is a signatory to the United Nations Convention on the Recognition and Enforcement of Foreign Arbitral Awards (the "New York Convention"), which historically has permitted reciprocal enforcement in the PRC of awards of arbitral bodies located in other New York Convention signatory countries. Following the resumption of sovereignty over Hong Kong by the PRC on 1 July 1997, the New York Convention no longer applies to the enforcement of Hong Kong arbitration awards in other parts of the PRC. On 21 June 1999, an arrangement was made between Hong Kong and the PRC for the mutual enforcement of arbitration awards. This new arrangement, which has been approved by the Supreme People's Court of the PRC (中國最高人民法院) and the Hong Kong Legislative Council, became effective on 1 February 2000. As far as the Directors are aware, no action has been brought in the PRC by any public shareholder of a PRC company to enforce an arbitration award granted in Hong Kong since 1 February 2000, and the outcome of enforcing such an arbitration award in the PRC under the new arrangement is therefore uncertain.

RISK FACTORS

RISKS RELATING TO THE PLACING

No prior public market for the H Shares

Prior to the Placing, there was no public market for the H Shares. The determination of the Placing Price for the H Shares was the result of negotiation between the Company and the Lead Manager, on behalf of the Placing Underwriters, and the Placing Price may differ significantly from the market price for the H Shares following the Placing. The Company has applied to list and deal in the H Shares on GEM. However, being listed on GEM does not guarantee that an active market for the dealing of the H Shares will develop following the Placing.

The liquidity and market price of H Shares may be volatile

The trading price and trading volume of H Shares may be volatile. The market price of H Shares may fluctuate substantially in response to factors such as changes in the Group's revenue, profit and cash flow, its ability to realise future business plans, acts of strategic alliance and/or acquisition, or fluctuations in product price. Any of the abovementioned factors may cause material and sudden changes in the trading price and trading volume of H Shares.

The trading price of the H Shares may also be subject to significant volatility in response to, among other things, the following factors:

- investors' perception of the Group;
- changes in the senior management of the Group;
- the depth and liquidity of the market for the H Shares; and
- general economic and other factors.

There is no assurance that these developments will not occur in the future. In addition, shares of the PRC companies listed on the Stock Exchange and shares of similar companies have experienced substantial price volatility in the past, and it is possible that the H Shares will be subject to changes in price that may not be directly related to the Group's financial or business performance.

Possible future dilution of Shareholders' interest in the Company

The Group may need to raise additional funds in the future to finance expansion of its operations or other new acquisitions or projects. If additional funds are raised through the issue of new equity-linked securities of the Company other than on a pro rata basis to the then existing Shareholders, the shareholding of the Shareholders may be reduced and the Shareholders' interest in the Company may be diluted. In addition, such newly-issued securities may have rights and preferences superior to those of the Shares.

Pursuant to Rule 17.29 of the GEM Listing Rules, no further Shares or securities convertible into equity securities of the Company (subject to certain exceptions) may be issued or form the subject of any agreement to issue within six months from the Listing Date.

RISK FACTORS

RISK RELATING TO CERTAIN REPRESENTATIONS IN THIS PROSPECTUS

Actual use of proceeds may deviate from original intention

The intended use of proceeds from the Placing of the New H Shares is set out in the paragraph headed “Reasons for the Placing and the use of proceeds” under the section headed “Statement of business objectives” in this prospectus. Currently, the Directors intend to apply the proceeds from the Placing of the New H Shares to the purposes mentioned in that paragraph. However, with the emergence of new opportunities and unforeseeable events, the Directors may (if they consider it to be in the best interests of the Company) apply the whole or part of the proceeds to other business plans or new projects or use the proceeds as operating fund or otherwise, or deposit them into a bank account in the PRC. As a result, the actual use of the proceeds may deviate from that originally intended as described in this prospectus. If the actual use of proceeds deviates from the original use described in this prospectus, the Company will make a separate announcement.

WAIVER FROM COMPLIANCE WITH THE GEM LISTING RULES

For the purpose of the listing of the H Shares on GEM, CPY has, on behalf of the Company, applied for the following waiver from the Stock Exchange in relation to the escrow arrangement requirements under Rule 13.16(1) of the GEM Listing Rules.

Escrow arrangement — waiver from strict compliance with Rule 13.16(1) of the GEM Listing Rules

Pursuant to Rule 13.16(1) of the GEM Listing Rules, every Initial Management Shareholder is required to place in escrow, with an escrow agent and on such terms as are acceptable to the Stock Exchange, its/his Relevant Securities during the Lock-up Period (or where that Initial Management Shareholder's Relevant Securities represent no more than 1% of the registered capital of the Company as at the Listing Date, for a period commencing on the date of this prospectus and ending on the date which is 6 months from the Listing Date).

As set out in the paragraph headed “Initial Management Shareholders” under the section headed “Substantial Shareholders and Initial Management Shareholders” in this prospectus, Sample Group, Nanjing Zhongbei, Huadong Technology, Sample Commerce City and Sha Min (沙敏) are Initial Management Shareholders. The Domestic Shares held by them are therefore subject to the requirement under Rule 13.16(1) of the GEM Listing Rules. However, since the Domestic Shares held by the Initial Management Shareholders are not represented by any form of physical scrip or title documents, the subject matter for custody by the escrow agent under Rule 13.16(1) of the GEM Listing Rules does not physically exist in any form available for custody purposes. Given that the Domestic Shares are in scripless form, the Initial Management Shareholders may not be able to create any pledge or charge by the deposit of the title documents in relation to their respective Domestic Shares or any part thereof.

In view of the foregoing, the Sponsor, for and on behalf of the Company, has applied to the Stock Exchange for a waiver from strict compliance with Rule 13.16(1) of the GEM Listing Rules in respect of the escrow arrangement and the waiver has been granted by the Stock Exchange.

INFORMATION ABOUT THIS PROSPECTUS AND THE PLACING

DIRECTORS' RESPONSIBILITY FOR THE CONTENTS OF THIS PROSPECTUS

This prospectus, for which the Directors collectively and individually accept full responsibility, includes particulars given in compliance with the GEM Listing Rules and the Companies Ordinance for the purpose of giving information with regard to the Group. The Directors, having made all reasonable enquiries, confirm that, to the best of their knowledge and belief:

- (a) the information contained in this prospectus is accurate and complete in all material respects and not misleading;
- (b) there are no other matters the omission of which would make any statement in this prospectus misleading; and
- (c) all opinions expressed in this prospectus have been arrived at after due and careful consideration and are founded on bases and assumptions that are fair and reasonable.

The Placing Shares are offered solely on the basis of the information contained and representations made in this prospectus. No person is authorised in connection with the Placing to give any information or to make any representation not contained in this prospectus, and any information or representation not contained herein must not be relied upon as having been authorised by the Company, the Placing Underwriters, the Sponsor, or any of their respective directors or any other person involved in the Placing.

UNDERWRITING

This prospectus is published in connection with the Placing which is sponsored by CPY and fully underwritten by the Placing Underwriters (subject to the Company and the Placing Underwriters agreeing on the Placing Price and the conditions of the Placing as set out in the paragraph headed "Conditions of the placing" in the section headed "Structure and conditions of the placing"). For further information relating to the underwriting arrangements, please refer to the section headed "Underwriting" in this prospectus.

CONSENT OF THE CSRC

On 26 March 2004, the CSRC gave its approval to the Company on the issue of H Shares and the listing of H Shares on GEM. In granting such consent, the CSRC accepts no responsibility for the financial soundness of the Company or the accuracy of any of the statements made or opinions expressed in this prospectus.

INFORMATION ABOUT THIS PROSPECTUS AND THE PLACING

SELLING RESTRICTIONS

No action has been taken to permit the Placing or the distribution of this prospectus in any jurisdictions (in particular the United States) other than Hong Kong. Accordingly, this prospectus may not be used for the purpose of, and does not constitute, an offer or invitation in any other jurisdictions or in any circumstances in which such offer or invitation is not authorised or to any person to whom it is unlawful to make such an offer or invitation.

Each person acquiring the Placing Shares will be required, and is deemed by his acquisition of the Placing Shares, to confirm that he is aware of the restrictions on offers of the Placing Shares described in this prospectus and that he is not acquiring, and has not been offered any Placing Shares in circumstances that contravene any such restrictions.

The distribution of this prospectus and the offering of the Placing Shares in certain jurisdictions are restricted by law and in particular, but without limitation, to following:

United States

This prospectus has not been registered under the US Securities Act and, accordingly may not be delivered within the United States, its territories or possessions or to, or for the benefit of, US persons (as defined under Regulation S of the US Securities Act), and the Placing Shares may not be offered or sold, transferred or delivered directly or indirectly, in the United States or to US persons except pursuant to an effective registration statement or pursuant to an exemption available under the US Securities Act.

United Kingdom

This prospectus has not been approved by an authorised person in the United Kingdom and has not been registered with the Registrar of Companies in the United Kingdom. This communication is directed solely at persons who (i) are outside the United Kingdom or (ii) have professional experience in matters relating to investments or (iii) are persons falling within Article 49(2)(a) to (e) of the Financial Services and Markets Act 2000 (Financial Promotion) Order 2001 (all such persons together being referred to as "relevant persons"). This communication must not be acted on or relied on by persons who are not relevant persons. Any investment or investment activity to which this communication relates is available only to relevant persons and will be engaged in only with relevant persons. The Placing Shares may not be offered or sold in the United Kingdom except to persons whose ordinary activities involve them in acquiring, holding, managing or disposing of investments, as principal or agent, for the purposes of their businesses or otherwise in circumstances which have not resulted and will not result in an offer to the public in the United Kingdom within the meaning of the Public Offer of Securities Regulations 1995 (as amended). In addition, any invitation or inducement to engage in investment activity (within the meaning of section 21 of the Financial Services and Market Act 2000 (the "FSMA")) in connection with the issue or sale of the Placing Shares may only be communicated or caused to be communicated in circumstances in which section 21(1) of the FSMA does not apply to the Company. All applicable provisions of the FSMA must be complied with in respect of anything done in relation to the Placing Shares in, from or otherwise involving the United Kingdom.

INFORMATION ABOUT THIS PROSPECTUS AND THE PLACING

Singapore

This prospectus has not been and will not be registered as a prospectus with the Monetary Authority of Singapore pursuant to the Securities and Futures Act, Chapter 289 of Singapore (the "SFA"), as there is currently no intention to offer the Placing Shares to the public or any member of the public in Singapore. Accordingly, the Placing Shares may not be offered for subscription or purchase or sold, nor may this prospectus or any other offering document be issued, circulated or distributed, directly or indirectly, to the public or any member of the public in Singapore, other than (i) pursuant to, or in accordance with, the conditions of an exemption to be invoked under Subdivision (4) of Division I of Part XIII of the SFA; or (ii) otherwise pursuant to, and in accordance with, the conditions of any other provisions of the SFA.

Japan

The Placing Shares have not been and will not be registered under the Securities and Exchange Law of Japan and are not being offered or sold and may not be offered or sold, directly or indirectly, in Japan or for the accession of any resident in Japan except (i) pursuant to an exemption from the registration and prospectus delivery requirements of the Securities and Exchange Law of Japan, and (ii) in compliance with any other applicable requirements of Japanese law.

Taiwan

The Placing Shares have not been and will not be approved by the Securities and Futures Commission of Taiwan under the Securities and Exchange Law of Taiwan to be issued, offered or sold in Taiwan and the Company has not been and will not be registered under the Company Law of Taiwan and related laws and regulations of Taiwan. Accordingly, the Placing Shares may not be issued, offered or sold, directly or indirectly, in Taiwan.

PRC

This prospectus may not be circulated or distributed in public in the PRC and the Placing Shares may not be offered or sold, directly or indirectly or offered or sold to any person for re-offering or resale, directly or indirectly, to any resident of the PRC except pursuant to applicable laws and regulations of the PRC.

APPLICATION FOR LISTING ON GEM

The Company has applied to the GEM Listing Committee for the listing of, and permission to deal in, the H Shares on GEM which are to be issued and sold pursuant to the Placing (including the H Shares which may fall to be issued upon the exercise of any options which may be granted under the Share Option Scheme).

As at the Latest Practicable Date, no part of the share or loan capital of the Company is currently listed or dealt in on any other stock exchange and save as herein disclosed and no such listing or permission to deal in, any part of the share or loan capital of the Company is being or proposed to be sought.

INFORMATION ABOUT THIS PROSPECTUS AND THE PLACING

Pursuant to Rules 25.08 and 25.09 of the GEM Listing Rules, at the time of listing and at all times thereafter, the Company must ensure that all H Shares are held by the public (except as otherwise permitted by the Stock Exchange), the H Shares must normally constitute not less than 10% of the total issued registered share capital of the Company, and the aggregate amount of H Shares and such other securities of the Company which are held by the public must constitute not less than 25% of the total issued registered share capital of the Company.

Any allotment or transfer made in respect of any placing of the Placing Shares will be void if permission for the listing of, and dealing in, the H Shares on GEM has been refused before the expiration of three weeks from the date of closing of the subscription lists or such longer period (not exceeding six weeks) as may, within the said three weeks, be notified to the Company by or on behalf of the Stock Exchange.

Only securities registered on the H Share register of members of the Company kept in Hong Kong may be traded on GEM unless the Stock Exchange otherwise agrees.

COMMENCEMENT OF DEALINGS IN THE SHARES

Dealings in the H Shares on GEM are expected to commence on Wednesday, 9 June 2004 and the H Shares will be traded in board lots of 1,000 H Shares.

STRUCTURE AND CONDITIONS OF THE PLACING

Details of the structure of the Placing, including its conditions, are set out under the section headed "Structure and conditions of the Placing" in this prospectus.

SHARES WILL BE ELIGIBLE FOR ADMISSION INTO CCASS

Subject to the granting of the listing of, and permission to deal in, the H Shares (including the H Shares which may be issued upon the exercise of any options which may be granted under the Share Option Scheme) on GEM and the compliance with the stock admission requirements of HKSCC, the H Shares will be accepted as eligible securities by HKSCC for deposit, clearance and settlement in CCASS with effect from the date of commencement of dealings in the H Shares on GEM or any other date as HKSCC may choose. Potential investors should seek the advice of their stockbroker or other professional adviser for details of those settlement arrangement and how such arrangement will affect their rights and interests. Settlement of transactions between participants of the Stock Exchange is required to take place in CCASS on the second business day after any trading day.

All activities under CCASS are subject to the General Rules of CCASS and CCASS Operational Procedures in effect from time to time. Investors should seek the advice of their stockbroker or other professional advisers for details of those settlement arrangements and how such arrangement will affect their rights and interests.

All necessary arrangements have been made for the H Shares to be admitted into CCASS. The Company shall ensure, as far as it is able, that the H Shares will remain admitted into CCASS.

INFORMATION ABOUT THIS PROSPECTUS AND THE PLACING

REGISTRATION OF SUBSCRIPTION, PURCHASE AND TRANSFER OF H SHARES

The Company has instructed Computershare Hong Kong Investor Services Limited, its Hong Kong share registrar, and Computershare Hong Kong Investor Services Limited has agreed not to register the subscription, purchase or transfer of any H Shares in the name of any particular holder unless and until such holder delivers a signed form to it in respect of those H Shares bearing statements to the effect that the holder:

- (i) agrees with the Company and each other Shareholder, and the Company agrees with such registered holder and each other Shareholder, to observe and comply with the Companies Ordinance, the GEM Listing Rules, the Company Law, the Special Regulations and the Articles of Association;
- (ii) agrees with the Company, each other Shareholder, Director, Supervisor, manager and officer of the Company, and the Company acting for itself and for each Director, Supervisor, manager and officer of the Company agrees with such registered holder and each other Shareholder, to refer all differences and claims arising from the Articles of Association or any rights or obligations conferred or imposed by the Company Law or other relevant laws and administrative regulations concerning the affairs of the Company to arbitration in accordance with the Articles of Association, and any reference to arbitration shall be deemed to authorise the arbitration tribunal to conduct hearing in open session and to publish its award which shall be final and conclusive;
- (iii) agrees with the Company and each other Shareholder that the H Shares in the Company are freely transferable by the holder thereof; and
- (iv) authorises the Company to enter into a contract on the holder's behalf with each of the Director, Supervisor, manager and officer of the Company whereby such Directors, Supervisors, managers and officers undertake to observe and comply with their obligations to the Shareholders as stipulated in the Articles of Association.

PROFESSIONAL TAX ADVICE RECOMMENDED

If you are unsure about the taxation implications of the subscription, purchase, holding or disposal of, dealing in, or the exercise of any rights in relation to the H Shares, you should consult an expert.

The Company, the Vendor, the Directors, the Sponsor, the Placing Underwriters, any of their respective directors, officers, employees and/or representatives and any other parties involved in the Placing do not accept responsibility for any tax effects on or liabilities resulting from the subscription for, or purchase, holding or disposal of, or dealing in or the exercise of any rights in relation to, the Placing Shares.

HONG KONG H SHARE REGISTER AND STAMP DUTY

All H Shares issued pursuant to the Placing will be registered on the Company's H share register of members maintained in Hong Kong. The Company's principal register of members will be maintained at the Company's head office in the PRC. Dealings in the Placing Shares registered on the Hong Kong H share register of members of the Company will be subject to Hong Kong stamp duty.

DIRECTORS AND SUPERVISORS

Name	Address	Nationality
Executive Directors		
Sha Min (沙敏)	5-102, Yue Ya Hu Garden Nanjing City Jiangsu PRC	Chinese
Chang Yong (常勇)	Room 304, Block 4, No. 13, Bei Dong Gua Shi Nanjing City Jiangsu PRC	Chinese
Guo Ya Jun (郭亞軍)	1201, Ruijin Villa 33 Rui Jin Road Nanjing City Jiangsu PRC	Chinese
Non-executive Directors		
Zhao Jing Cheng (趙竟成)	Unit 4, Block 1, No. 4, Hong You Alley Nanjing City Jiangsu PRC	Chinese
Zhang Yin Qian (張銀千)	1-410 Bei Yuan San Cun Nanjing City Jiangsu PRC	Chinese
Zhao Wen (趙文)	405, Block 8, No. 43, Fo Xin Qiao Xuan Wu District Nanjing City Jiangsu PRC	Chinese
Zhu De Xiang (朱德祥)	405, Block 21, No. 10, Xin Men Kou Gu Lou District Nanjing City Jiangsu PRC	Chinese

DIRECTORS AND SUPERVISORS

Name	Address	Nationality
Independent non-executive Directors		
Zhang Zhan (張展)	401, Block 88 Feng Huang Garden Gu Lou District Nanjing City Jiangsu PRC	Chinese
Wang Wei (王煒)	Room 605, New Building 8, 28 Lan Yuan Xuanwu District Nanjing City Jiangsu PRC	Chinese
Lau Shek Yau John (劉石佑)	2/F, Clement Court No. 56 Mount Butler Road Hong Kong	Chinese
Supervisors		
Tian Tao (田濤)	Room 404, Block 8 Yue Ya Hu Garden Nanjing City Jiangsu PRC	Chinese
Sun Huai Dong (孫懷東)	Room 1201, Block 8 Qing Xi Building 19 Hou Zai Men Nanjing City Jiangsu PRC	Chinese
Du Jin (杜瑾)	Room 204, Block 4 No. 47, Shen Jia Alley Bai Xia District Nanjing City Jiangsu PRC	Chinese
Independent Supervisors		
Dai Jian Jun (戴建軍)	Room 1802, No. 2, Yang Guang Guang Chang Long Jiang Xiao Qu Nanjing City Jiangsu PRC	Chinese
Ma Lin Ping (馬林萍)	Room 201, Block 1, No. 23 Lan Yuan Xuanwu District Nanjing City Jiangsu PRC	Chinese

PARTIES INVOLVED IN THE PLACING

Sponsor

Core Pacific – Yamaichi Capital Limited
36th Floor
Cosco Tower
Grand Millennium Plaza
183 Queen's Road Central
Hong Kong

Lead Manager

Core Pacific – Yamaichi International (H.K.) Limited
36th Floor
Cosco Tower
Grand Millennium Plaza
183 Queen's Road Central
Hong Kong

Co-Lead Managers

Crosby Limited
Room 2701-3
Citibank Tower
3 Garden Road
Central
Hong Kong

First Shanghai Securities Limited
19th Floor, Wing On House
71 Des Voeux Road
Central
Hong Kong

Co-Managers

Asian Capital (Corporate Finance) Limited
Suite 1006, Bank of America Tower
12 Harcourt Road
Central
Hong Kong

CSC Securities (HK) Limited
3204-07, 32/F
COSCO Tower
Grand Millennium Plaza
183 Queen's Road Central
Hong Kong

PARTIES INVOLVED IN THE PLACING

First Asia Finance Group Limited
Room 3505-06, 35th Floor, Edinburgh Tower
The Landmark
15 Queen's Road Central
Hong Kong

Grand Vinco Capital Limited
Room 902, 9/F
Far East Finance Centre
16 Harcourt Road
Hong Kong

Taiwan Securities (HK) Co., Ltd.
Rm 4001-3, 40/F, Tower 2
Lippo Centre
89 Queensway
Central
Hong Kong

TIS Securities (HK) Limited
Unit 1010, 10/F
Tower Two, Lippo Central
89 Queensway
Hong Kong

Legal advisers to the Company

As to Hong Kong law:
Kwok & Yih
37th Floor, Gloucester Tower
The Landmark
Central
Hong Kong

As to PRC law:
Commerce & Finance Law Office
714 Huapu International Plaza
19 Chaowai Avenue
Beijing
PRC

Legal advisers to the Sponsor and the Placing Underwriters

As to Hong Kong law:
Sidley Austin Brown & Wood
39th Floor
Two International Finance Centre
8 Finance Street
Central
Hong Kong

PARTIES INVOLVED IN THE PLACING

Auditors and reporting accountants

Deloitte Touche Tohmatsu
Certified Public Accountants
26th Floor, Wing On Centre
111 Connaught Road Central
Hong Kong

Property valuer

Vigers Appraisal & Consulting Limited
10th Floor
The Grande Building
398 Kwun Tong Road
Kowloon
Hong Kong

CORPORATE INFORMATION

Registered office	Room 103, Building No. 1, Ruan Jian Chuang Ye Zhong Xin High Technology Development Region Nanjing City Jiangsu Province PRC
Head office and principal place of business in the PRC	7th Floor, No. 54 Jiangsu Software Park 168 Longpan Zhong Road Nanjing City Jiangsu Province PRC
Principal place of business in Hong Kong	Rooms 3705 to 3706 37th Floor, Gloucester Tower The Landmark Central Hong Kong
Website address	www.sampletech.cn (the contents of which do not constitute part of this prospectus)
Company secretary	Chan Wei Wei (陳慧慧) AHKSA, ACCA
Compliance officer	Guo Ya Jun (郭亞軍)
Qualified accountant	Chan Wei Wei (陳慧慧) AHKSA, ACCA
Audit committee	Zhang Zhan (張展) (chairman) Wang Wei (王煒) Lau Shek Yau John (劉石佑)
Authorised representatives	Guo Ya Jun (郭亞軍) Chan Wei Wei (陳慧慧) AHKSA, ACCA
Authorised person to accept service of process and notice	Chan Wei Wei (陳慧慧) AHKSA, ACCA
Hong Kong H shares registrar and transfer office	Computershare Hong Kong Investor Services Limited Shops 1712–1716, 17th Floor Hopewell Centre 183 Queen's Road East Wanchai Hong Kong

CORPORATE INFORMATION

Principal bankers

Industrial and Commercial Bank of China
(Nanjing Xinjiekou Branch)
95 Hanzhong Road
Nanjing City
Jiangsu Province
PRC

Shanghai Pudong Development Bank
(Nanjing Branch)
90 Zhongshan East Road
Nanjing City
Jiangsu Province
PRC

THE VIDEO SECURITY MARKET IN THE PRC

The Group is principally engaged in the provision and operation of video security system solutions, specifically in the traffic monitoring and control sector and the customs logistics monitoring sector. In the past, traffic monitoring and control activities which were performed manually required extensive labour input to operate the system solutions and perform judgemental actions. With the assistance of the information technology and the video security system solutions provided by the Group, the daily routine procedures and decision-making are simplified and manual and documentary work are reduced.

(I) Traffic monitoring and control system solutions

The PRC government places emphasis and effort in the development of traffic control technologies. According to the 'Ninth Five-Year' Plan (1996 to 2000) and the Long-term Plan to 2010 (一九九六至二零零零年「九五」規劃和到二零一零年長期規劃), the PRC government will reinforce the implementation of the Improve Traffic Through Technology and Education (科教興交) strategy.

The growing demand for the informationalisation of policy of the traffic/transport ministries of the PRC and, in particular, the needs of provincial public security traffic/police authorities to set up automatic traffic monitoring and control/public security monitoring and control systems, has created a potential market for the Group in the traffic monitoring and control sector.

In April 2002, the Ministry of Science and Technology of the PRC (中華人民共和國科學技術部) has admitted the Project for the Development and Demonstration of Key Technologies for ITS (智能交通系統關鍵技術開發和示範工程) as a key Technologies R&D Programme of the 'Tenth Five-Year' Plan (「十五」國家科技攻關計劃).

The Electronic Information Industry Development Funds (電子信息產業發展基金) which aim at encouraging the research, development and industrialisation of electronic information products in the PRC are jointly managed by the MOF and the MII. In the "Guidebook of Information Industry Electronic Development Funds in 2002" (《二零零二年度電子信息產業發展基金項目指南》), the MII categorised digitalised video and graphic processing products, security control network, comprehensive automatic control system for traffic of municipal tracks, comprehensive information processing products and control system for vehicles as key development items.

In the Highway and Waterway Transport Informationalisation 'Ninth Five-Year' Plan and the Guiding Principles up to 2010 (公路水運交通信息化「九五」規劃和二零一零年方針紀要), the Ministry of Communications of the PRC (中華人民共和國交通部) proposed to establish a modern information network for the nation-wide transport system based on computer, communication and information network technology.

In early 2000, ClearWay Project (暢通工程) was jointly promoted and implemented by the Ministry of Public Security of the PRC (中華人民共和國公安部) and the Ministry of Construction of the PRC (中華人民共和國建設部). The project focuses on improving the management of city road traffic and concentrates strength in solving problems affecting the smooth flow of traffic on city roads. It aims to speed up the scientific process, the traffic management legislation process and the standardisation of construction with a view to improving the traffic environment of city roads. Altogether 36 major cities, two prefecture-level cities and two county-level cities as confirmed by each province/autonomous region in the PRC are included under the Clear Way Project (暢通工程).

INDUSTRY OVERVIEW

Also in 2000, the Safe Road (平安大道) campaign was promoted by the Ministry of Public Security of the PRC (中華人民共和國公安部) for nation-wide application with an aim to attack and eliminate serious overloading, improper use of traffic lane, driving without licence and unregistered vehicles travelling on the roads.

According to a report of Xinhuanet (新華網) on 9 January 2002 which was based on a report from the website of the Ministry of Public Security of the PRC (中華人民共和國公安部), the State's investment in municipal traffic management facilities in 2001 amounted to RMB104.4 billion, representing an increase of 58% from 2000.

According to a report of *chinacitynet.com* on 17 July 2003, the total population of the top 30 cities in the PRC had reached approximately 285 million by the end of 2002. The market demand for municipal traffic management systems grows with the burgeoning economy of the PRC.

According to the Statistical Report on the Development of Land and Water Transport Sector from 2000 to 2002 (2000年至2002年公路水路交通行業發展統計公報) published by the Ministry of Communications of the PRC (中華人民共和國交通部) and the 2003 Economic and Social Development Statistical Report (2003年國民經濟和社會發展統計公報) published by the National Bureau of Statistics of the PRC (中華人民共和國國家統計局), the aggregate length of highways in the PRC grew from approximately 16,300 km in 2000 to approximately 29,800 km in 2003, representing a compound annual growth rate of approximately 22.3%. Further, according to the statistics of the National Bureau of Statistics of the PRC (中華人民共和國國家統計局), the number of vehicles in operation in the PRC had reached 20 million by the end of 2002. Such growth promotes the opportunity and necessity of informationalisation for the traffic monitoring and control sector in the PRC. The following chart sets out the aggregate lengths of highways in the PRC from 2000 to 2003 respectively:

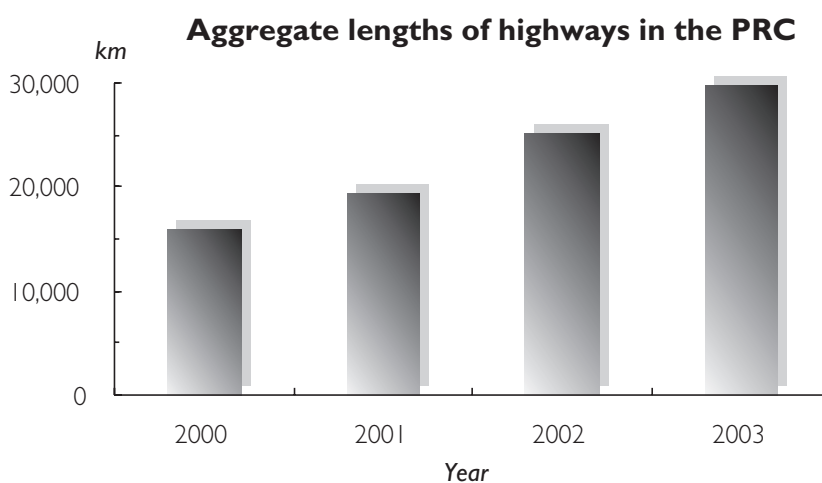

Source: *Statistical Report on the Development of Land and Water Transportation Sector from 2000 to 2002 (2000年至2002年公路水路交通行業發展統計公報)* by the Ministry of Communications of the PRC (中華人民共和國交通部) (2000-2002 data) and *2003 Economic and Social Development Statistical Report (2003年國民經濟和社會發展統計公報)* by the National Bureau of Statistics of the PRC (中華人民共和國國家統計局) (2003 data).

INDUSTRY OVERVIEW

Along with further implementation of the Improve Traffic Through Technology and Education (科教興交) strategy, the Directors believe that the market for the informationalisation of the traffic sector has potential for growth and present business opportunities for the Group.

According to a report of "Fa Zhi Daily" (《法制日報》) dated 25 January 2002, the Ministry of Public Security of the PRC (中華人民共和國公安部) will establish the Social Security Prevention and Controlling Mechanism (維護社會治安的長效機制) to coordinate between commanding centres and the police reporting services. The Directors believe that the future business of the Group with regard to traffic control and public security can assist the Ministry of Public Security of the PRC (中華人民共和國公安部) in achieving this objective and the Group will also engage itself in the research and development in that respect.

According to an article of "China Communication News" (《中國交通報》) published on the website of CHINAHIGHWAY(中國公路網) at www.chinahighway.com on 6 November 2003, it is expected that in the coming six years, the PRC government would spend at least RMB40 billion to enhance its intelligent transportation system.

(2) Customs logistics monitoring system solutions

According to the 2004 China's Customs Statistics (二零零四年中國海關統計), import and export trade in 1998 and 2003 amounted to US\$324 billion and US\$851.2 billion respectively. The Directors believe that the rapid growth of the PRC international trade highlights the pressing demand for PRC customs informationalisation, which in turn creates a substantial opportunity for the Group for the development of customs logistics monitoring sector:

In 2001, despite of unfavourable conditions in the global economy such as the "September 11" incident in the US, import and export of the PRC prosper under the favourable factors such as the PRC's entry into the WTO. According to the 2004 China's Customs Statistics (二零零四年中國海關統計), the PRC's total import and export volume amounted to US\$509.7 billion in 2001.

Cargos and containers processed in the PRC had also realised a continuous growth from 2000 to 2003. The amount of cargos processed at ports in the PRC increased from approximately 2.2 billion tonnes in 2000 to approximately 3.3 billion tonnes in 2003, representing a compound annual growth rate of approximately 14.5%. During the same period, number of containers processed in the PRC also surged

INDUSTRY OVERVIEW

from approximately 23.5 million in 2000 to approximately 48.0 million in 2003, representing a compound annual growth rate of approximately 26.9%. The following charts set out the amount of cargos and the number of containers processed in the PRC from 2000 to 2003 respectively:

Amount of cargos processed at ports in the PRC

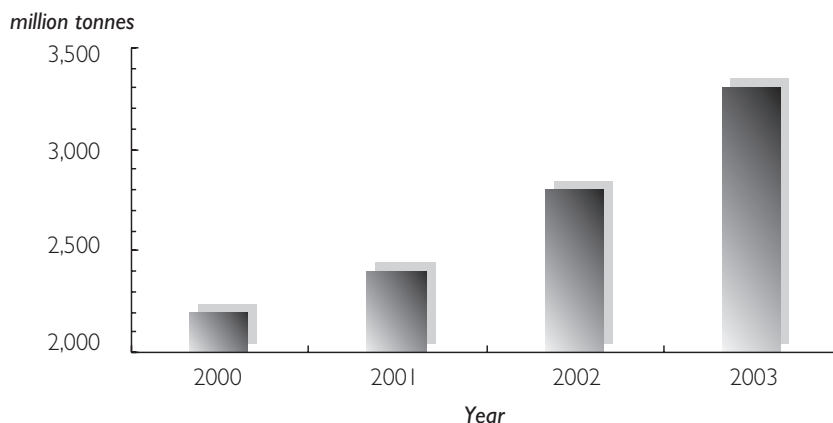

Source: *Statistical Report on the Development of Land and Water Transportation Sector from 2000 to 2002* (2000年至2002年公路水路交通行業發展統計公報) by the Ministry of Communications of the PRC (中華人民共和國交通部) (2000-2002 data) and *2003 Economic and Social Development Statistical Report* (2003年國民經濟和社會發展統計公報) by the National Bureau of Statistics of the PRC (中華人民共和國國家統計局) (2003 data).

Number of containers processed in the PRC

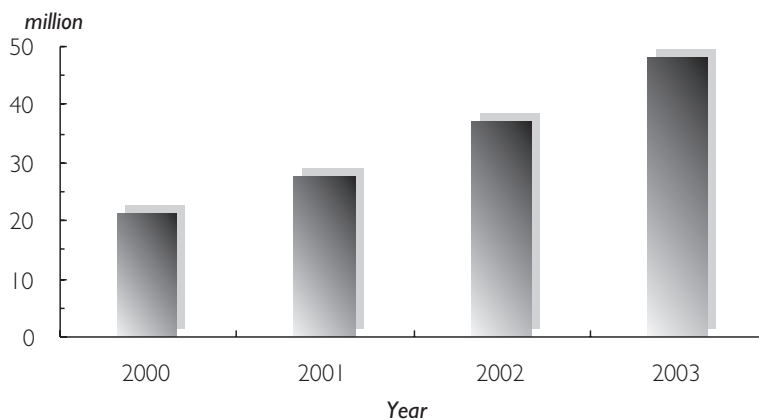

Source: *Statistical Report on the Development of Land and Water Transportation Sector from 2000 to 2002* (2000年至2002年公路水路交通行業發展統計公報) by the Ministry of Communications of the PRC (中華人民共和國交通部) (2000-2002 data) and *Report of the Xinhua News Agency* (新華社) issued on 11 January 2004 (2003 data).

The Directors believe that such growth represents a good prospect for the Group to engage in the business of providing video security system solutions for the customs logistics monitoring sector in the PRC.

As an administrative and executing organisation of the State Council in charge of import and export, processing trade, tax-exemption operation, customs examination, tariff and relevant tax levy, the PRC customs undertake a major responsibility of safeguarding the economy of the PRC. The Directors believe that along with the flourishing import and export business of the PRC, the workload of the PRC customs in controlling goods transport, fighting smuggling, levying tariff and import duties grows constantly. Full scale informationalisation and network management of the PRC customs have become essential for the future development thereof.

INDUSTRY OVERVIEW

According to a report published on Xinhuanet (新華網), a website maintained and operated by Xinhua News Agency (新華社), on 1 April 2002 which was based on the "People's Daily" (《人民日報》), the General Customs Administration of the PRC (中華人民共和國海關總署) required the reinforcement of regulation, reduction of customs clearance costs and the strengthening of export and external trade. At present, the PRC customs has to accomplish the change from its sole emphasis on goods to an emphasis on both goods and enterprises, the change of time span from the short period of customs control to an extended period of control before and after customs clearance, the change of information control from decentralisation to systematic centralisation, the change from single-manned counters to consolidated management, and the change from human-oriented to more technology-based methods. Accordingly, the PRC customs has regarded customs informationalisation as an effective measure for strengthening control.

RELEVANT PRC LAWS AND REGULATIONS RELATING TO THE INDUSTRY AND THE GROUP

Software products

On 27 October 2000, the Measures on the Administration of Software Products (軟件產品管理辦法) (the "S.P. Measures") was promulgated by the MII for implementation.

As provided in the S.P. Measures, activities such as development, production, sale, import and export of software products shall comply with the relevant PRC laws, rules, regulations and standards. No entities or individuals shall develop, produce, sell, import or export any software products containing the following: (a) information that infringes other people's intellectual property rights; (b) computer viruses; (c) contents which may endanger the safe operation of computer systems; (d) contents which are prohibited by the State from circulation; and (e) contents not complying with the PRC standards for software products.

According to the S.P. Measures, software production units should (1) be a co-operative legal entity whose scope of business include R&D and production of computer software; (2) possess the prerequisite and technology to produce software; (3) produce at a fixed location; and (4) have the procedure and ability to maintain quality control of software products.

There is a registration and filing system for software products. Software products without registration and filing or which have been withdrawn from registration shall not be used or sold within the PRC.

The S.P. Measures also contain relevant provisions to regulate manufacturers of software products.

Software enterprises

On 24 June 2000, the State Council of PRC promulgated the Several Policies on Encouraging the Development of Software Industry and Integrated Circuit Industry (鼓勵軟件產業和集成電路產業發展的若干政策) (the "Encouragement Policies"), which provides a series of preferential policies for software industry in various fields, such as investment, financing, tax, and income distribution. The Encouragement Policies also supports the financing of software enterprises by way of overseas listing. Recognised software enterprises are entitled to the preferential treatments under the Encouragement Policies.

On 16 October 2000, the Criteria for Confirmation and Measures on Administration of Software Enterprises (Trial Implementation) (軟件企業認定標準及管理辦法(試行)) (the "Software Enterprises Measures") was promulgated for implementation.

INDUSTRY OVERVIEW

The Software Enterprises Measures contain regulations by means of which the relevant responsible PRC government departments manage, supervise and coordinate software enterprises, and also manage the certification of software enterprises. These measures also state the certification standards and reviewing process on software enterprises.

The Company and its subsidiary Golden Dragon Software have been granted the Certificate for the Confirmation of Software Enterprises (軟件企業認定證書) by the Jiangsu Province Information Industry Department (江蘇省信息產業廳).

Video security products and system solutions

The Provisional Regulations for the Management of Security Preventive Works for Social and Public Security and its Qualification Certificate of Jiangsu Province (江蘇省社會公共安全技術防範工程和資格証管理的暫行規定) (the "Security Regulations") was promulgated and implemented by the Public Security Department of Jiangsu Province (江蘇省公安廳) on 28 February 1996.

The Security Regulations divide the scale of security preventive works into three classes, accordingly, the qualification certificates are divided into three grades. The first class of security preventive work is project processing the first class of risks or with investment cost exceeding RMB1,000,000. The second class of security preventive work is project processing the second class of risks or with investment cost exceeding RMB300,000 but less than RMB1,000,000. The third class of security preventive work is project processing the third class of risks or with investment cost less than RMB300,000. The Security Regulations also provide for the reporting criteria and procedures of each grading of qualification certificate relating to security preventive works.

On 1 January 2003, the Company was granted the Qualification Certificate for the Design and Construction of Security Preventive System (Works) of Jiangsu Province (Grade one) (江蘇省安全技術防範系統(工程)設計施工資格證書(一級)) by the Security Technology Office of the Public Security Department of Jiangsu Province (江蘇省公安廳技術防範辦公室).

Qualification management of construction companies

The Regulations for the Qualification Management of Construction Companies (建築業企業資質管理規定) ("Qualification Regulations") was implemented on 1 July 2001.

The Qualification Regulations categorise the construction companies into three different types of qualifications, namely the master construction contract, the professional contract and the subcontract of labour. Each of these construction qualifications was then, with reference to its nature of works and technical characteristics, sub-categorised into several qualification classes, each of which was further divided into certain grades according to the related criteria.

According to the Grading Standards for the Qualification of Construction Companies (建築業企業資質等級標準) issued on 20 April 2001 and subsequently implemented on 1 July 2001 by the Head of Construction Management under the Construction Ministry, the qualification of professional contractor for intelligent projects could be divided into Grade one, Grade two and Grade three. On 19 November 2002, the Company was granted the Certificate for the Qualification of Construction Companies (Grade three) (建築業企業資質證書(三級)) and was qualified as a Grade three professional contractor for Intelligent Construction works to undertake intelligent construction works with contract values of RMB6 million or below.

GENERAL OVERVIEW OF THE GROUP

SHAREHOLDING STRUCTURE

The following table illustrates the shareholding structure of the Company immediately after the completion of the Placing (without taking into account any Shares which may fall to be issued upon the exercise of any options granted under the Share Option Scheme):

Name of Shareholder	Number of Shares held	Class of securities	Approximate percentage of shareholding (%)
Sample Group (Note 1)	18,000,000	Domestic Shares	27.91
Huadong Technology (Note 2)	12,000,000	Domestic Shares	18.60
Nanjing Zhongbei (Note 3)	12,000,000	Domestic Shares	18.60
Sample Commerce City	1,650,000	Domestic Shares	2.56
Sha Min (沙敏)	450,000	Domestic Shares	0.70
Public Shareholders	20,400,000	H Shares (Note 4)	31.63
Total	<u>64,500,000</u>		<u>100.00</u>

Notes:

1. Sample Group has nominated Sha Min (沙敏), Mr. Chang and Mr. Guo as executive Directors and Mr. Sun as a Supervisor.
2. Huadong Technology has nominated Zhao Jing Cheng (趙竟成) and Zhang Yin Qian (張銀千) as non-executive Directors.
3. Nanjing Zhongbei has nominated Zhao Wen (趙文) and Zhu De Xiang (朱德祥) as non-executive Directors.
4. The H Shares comprise 19,500,000 New H Shares and 900,000 Sale H Shares.

The Company is offering 19,500,000 New H Shares for subscription and the Vendor is offering 900,000 Sale H Shares for sale under the Placing. The number of H Shares held by the public will represent approximately 31.63% of the registered capital of the Company immediately after the completion of the Placing (without taking into account any Shares which may fall to be issued upon the exercise of any options granted under the Share Option Scheme). The registered capital of the Company immediately after the completion of the Placing (without taking into account any Shares which may fall to be issued upon the exercise of any options granted under the Share Option Scheme) will be RMB64,500,000 divided into 64,500,000 Shares of RMB1.00 each. The Company's structure immediately after the completion of the Placing (without

GENERAL OVERVIEW OF THE GROUP

taking into account any Shares which may fall to be issued upon the exercise of any options granted under the Share Option Scheme) will be as follows:

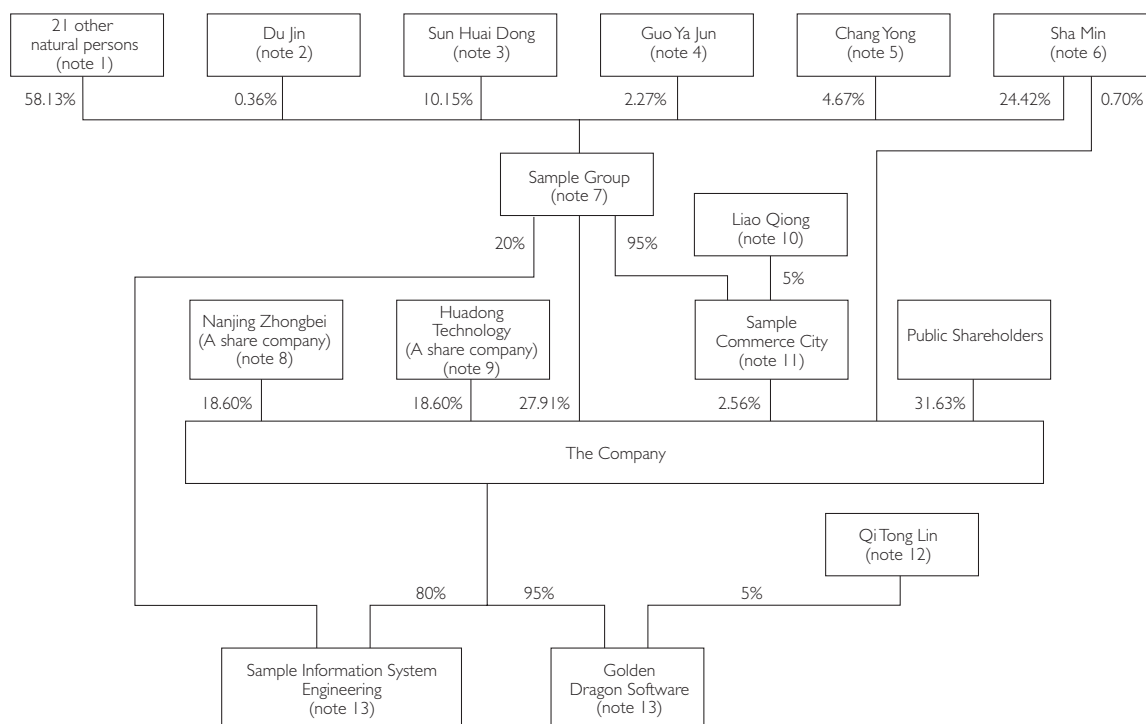

Notes:

- I. The names of the 21 other natural persons and their respective equity interest in Sample Group are as follows:

Name of shareholder	Percentage of equity interest held
Cai Long (蔡龍)	12.16%
Zhu Xiao Hui (朱曉暉)	7.39%
Guo Min Ke (郭明科)	5.62%
Yu You Geng (虞友庚)	5.48%
Cai Ju Ying (蔡菊英)	4.55%
Liao Qiong (廖瓊)	3.58%
Huang Shen (黃申)	2.86%
Xu Qiao Ling (徐巧玲)	2.79%
Peng Xiu Juan (彭秀娟)	2.52%
Qi Tong Lin (祁同林)	2.00%
Zong Xin Zhi (宗新志)	2.00%
Fei Chun Feng (費春風)	1.82%
Cheng Bo (陳波)	1.70%
Fu Yu Qing (富煜清)	0.66%
Liu Wei Ping (劉偉平)	0.61%
Hong Qi Sheng (洪啓生)	0.61%
Ding Jia (丁佳)	0.49%
Wang De Hua (王德華)	0.36%
Wang Li Sheng (王麗生)	0.33%
Liu Min (劉民)	0.30%
Dai Xiao Yu (戴曉玉)	0.30%
Total	58.13%

GENERAL OVERVIEW OF THE GROUP

Cai Long (蔡龍) and Zhu Xiao Hui (朱曉暉) are directors of Sample Group.

Guo Min Ke (郭明科) is a director and general manager of Sample Group.

Liao Qiong (廖瓊) is a manager of the finance department of Sample Group. Please refer to note 10 for further information regarding Liao Qiong (廖瓊).

Yu You Geng (虞友庚) and Xu Qiao Ling (徐巧玲) are supervisors of Sample Group.

Qi Tong Lin (祁同林) is a member of the senior management of the Company. Please refer to note 12 for further information of Qi Tong Lin (祁同林).

Fu Yu Qing (富煜清) is a member of the senior management of the Company.

Save as disclosed in this prospectus, none of the 21 other natural persons has participated or intends to participate in the management of Sample Group or the Company.

Save as disclosed in this prospectus, each of them is an Independent Third Party.

Dai Xiao Yu (戴曉玉) and Qi Tong Lin (祁同林), 2 of the 21 other natural persons, are altogether acting with Sha Min (沙敏), Sun Huai Dong (孫懷東), Chang Yong (常勇) and Guo Ya Jun (郭亞軍) as a group to hold an aggregate of over 43.81% interest in the registered capital of Sample Group throughout the Track Record Period.

Save as disclosed in the prospectus, all of the 21 other natural persons have no relationship amongst themselves and other shareholders of Sample Group.

2. Du Jin (杜瑾) is a Supervisor. Ms. Du is directly interested in approximately 0.36% of the registered capital of Sample Group which in turn will be directly interested in approximately 27.91% of the registered capital of the Company immediately after the completion of the Placing (without taking into account any Shares which may fall to be issued upon the exercise of any options granted under the Share Option Scheme).
3. Sun Huai Dong (孫懷東) is a Supervisor. Mr. Sun is directly interested in approximately 10.15% of the registered capital of Sample Group which in turn will be directly interested in approximately 27.91% of the registered capital of the Company immediately after the completion of the Placing (without taking into account any Shares which may fall to be issued upon the exercise of any options granted under the Share Option Scheme).
4. Guo Ya Jun (郭亞軍) is an executive Director and the deputy general manager of the Company. He is also a director of Sample Information System Engineering. Mr. Guo is directly interested in approximately 2.27% of the registered capital of Sample Group which in turn will be directly interested in approximately 27.91% of the registered capital of the Company immediately after the completion of the Placing (without taking into account any Shares which may fall to be issued upon the exercise of any options granted under the Share Option Scheme).
5. Chang Yong (常勇) is an executive Director and the general manager of the Company. He is also a director of Sample Group, Golden Dragon Software and Sample Information System Engineering. Mr. Chang is directly interested in approximately 4.67% of the registered capital of Sample Group which in turn will be directly interested in approximately 27.91% of the registered capital of the Company immediately after the completion of the Placing (without taking into account any Shares which may fall to be issued upon the exercise of any options granted under the Share Option Scheme).
6. Sha Min (沙敏) is an executive Director and the chairman of the Company. He is also a director of Sample Group, Golden Dragon Software and Sample Information System Engineering. He will be directly interested in approximately 0.7% of the registered capital of the Company immediately after the completion of the Placing (without taking into account any Shares which may fall to be issued upon the exercise of any options granted under the Share Option Scheme). He is also interested in approximately 24.42% of the registered capital of

GENERAL OVERVIEW OF THE GROUP

Sample Group which in turn will be directly interested in approximately 27.91% of the registered capital of the Company immediately after the completion of the Placing (without taking into account any Shares which may fall to be issued upon the exercise of any options granted under the Share Option Scheme). Accordingly, the attributable interest of Sha Min (沙敏) in the Company through Sample Group will be approximately 6.82%. His total shareholding interest in the Company (including direct and attributable interest) will be approximately 7.52% immediately after the completion of the Placing (without taking into account any Shares which may fall to be issued upon the exercise of any options granted under the Share Option Scheme).

To the best of the Directors' knowledge, Sha Min (沙敏) and his associates have no business or interest that competes or may compete with the business of the Group and have no other conflict of interest with the Group pursuant to Rule 11.04 of the GEM Listing Rules.

7. Sample Group is a limited liability company established in the PRC on 12 June 1993 and its former name was Sample Industry.

Registered capital	:	RMB33 million
Registration number of the business licence	:	3201001005848
Registered address	:	No. 454 Zhujiang Road, Xuanwu District, Nanjing
Legal representative	:	Guo Ming Ke (郭明科)
Name of directors	:	Guo Ming Ke (郭明科), Sha Min (沙敏), Cai Long (蔡龍), Chang Yong (常勇) and Zhu Xiao Hui (朱曉暉)
Principal banker	:	Nanjing Commercial Bank Ji Ming Si Office (南京市商業銀行雞鳴寺支行)
Auditors	:	Jiangsu Su Jian Certified Public Accountants (江蘇蘇健聯合會計師事務所)

The scope of business of Sample Group is the research, manufacture and sales of electronic products and communication equipment (excluding ground reception unit for satellite), apparatus and devices, and machinery; technological development of computer hardware and software, and technology services; computer network system integration; design and implementation of industry automation projects, investment in electronic technology projects; warehousing and transportation.

Sample Group is interested in approximately 20% of the equity interest in Sample Information System Engineering, approximately 27.91% of the equity interest in the Company and approximately 95% of the equity interest in Sample Commerce City.

Sample Group has nominated Sha Min (沙敏), Chang Yong (常勇) and Guo Ya Jun (郭亞軍) as the executive Directors and Sun Huai Dong (孫懷東) as a Supervisor.

GENERAL OVERVIEW OF THE GROUP

The structure of the registered capital of Sample Group is as follows:

Name of shareholder	Approximate percentage of the registered capital of Sample Group
Sha Min (沙敏)	24.42%
Cai Long (蔡龍)	12.16%
Sun Huai Dong (孫懷東)	10.15%
Zhu Xiao Hui (朱曉暉)	7.39%
Guo Min Ke (郭明科)	5.62%
Yu You Geng (虞友庚)	5.48%
Chang Yong (常勇)	4.67%
Cai Ju Ying (蔡菊英)	4.55%
Liao Qiong (廖瓊)	3.58%
Huang Shen (黃申)	2.86%
Xu Qiao Ling (徐巧玲)	2.79%
Peng Xiu Juan (彭秀娟)	2.52%
Guo Ya Jun (郭亞軍)	2.27%
Qi Tong Lin (祁同林)	2.00%
Zong Xin Zhi (宗新志)	2.00%
Fei Chun Feng (費春風)	1.82%
Cheng Bo (陳波)	1.70%
Fu Yu Qing (富煜清)	0.66%
Liu Wei Ping (劉偉平)	0.61%
Hong Qi Sheng (洪啓生)	0.61%
Ding Jia (丁佳)	0.49%
Wang De Hua (王德華)	0.36%
Du Jin (杜瑾)	0.36%
Wang Li Sheng (王麗生)	0.33%
Liu Min (劉民)	0.30%
Dai Xiao Yu (戴曉玉)	0.30%
Total	<u>100.00%</u>

Sample Group has undertaken to the Company and the Stock Exchange that, during the Lock-up Period, it will not, save as provided in Rule 13.18 of the GEM Listing Rules, (i) dispose of (nor enter into any agreement to dispose of) nor permit the registered holder to dispose of (or to enter into any agreement to dispose of) any of its equity interest in the Company; or (ii) otherwise create (nor enter into any agreement to create) nor permit the registered holder to create (or to enter into any agreement to create) any options, rights, interests or encumbrances in respect of any such interest.

Each of the shareholders of Sample Group has undertaken to the Company and the Stock Exchange that he/she will not dispose of (nor enter into any agreement to dispose of) any of his/her equity interest in Sample Group for a period of 12 months from the Listing Date.

To the best of the Directors' knowledge, Sample Group and its associates have no business or interest that competes or may compete with the business of the Group and have no other conflict of interest with the Group pursuant to Rule 11.04 of the GEM Listing Rules.

GENERAL OVERVIEW OF THE GROUP

8. Nanjing Zhongbei is a joint stock limited liability company established in the PRC on 10 July 1992 and its A shares commenced listing on the Shenzhen Stock Exchange on 6 August 1996. Details of Nanjing Zhongbei as appeared in its 2003 annual report are set out below:

Registered capital	:	RMB197,183,000
Registration number of the business licence	:	3201001003512
Registered address	:	No. 16 Tong Jiang Road, Jianye District, Nanjing
Legal representative	:	Xue Le Qun (薛樂群)
Name of directors	:	Xu Yi Min (徐益民), Chen Hui Yi (陳惠怡), Hu Zheng Ming (胡爭鳴), Guo Shi Ping (郭試平), Zhou Xue Xin (周學信), Xu Zheng Gou (許正苟), Yang Rong Hua (楊榮華), Li Hua Fei (李華飛), Xue Le Qun (薛樂群)
Principal banker	:	Industrial and Commercial Bank of China, Nanjing Branch and Han Zhong Men Office (中國工商銀行南京分行漢中門支行)
Auditors	:	Nanjing Yonghua Certified Public Accountants (南京永華會計師事務所有限公司)
Stock code	:	000421

The scope of business of Nanjing Zhongbei is motor vehicle hiring; passenger transportation on highway across provinces and cities; coach hiring; motor vehicle maintenance and repair; vehicle ticket agency; tour services (2nd categories); (design, production and agency service for press, publications and three-dimensional animated advertisement; promoting agent for advertisements on the body of motor vehicle, outdoor and gift commercials; franchised plate for community; sales and complementary services for motor vehicle); motor vehicle accessories; provision of groceries, daily commodities, and stationery; computers and accessories; craftsmanship products (excluding gold and silver ornaments); metal raw materials; ironmongery alternating current power (excluding power booster); building materials (selling); (development, construction and sales of property real estates; leasing of commodity houses; driving training; parking area); training on motor vehicle; chemical engineering products; sales of decorative materials; production and sales of clothing, hats and shoes repairing; property management; interior decoration; (accommodation, food and beverage services, flour, food additives). operations stated in brackets are applicable to branches only; highway transportation; economic information enquiries services; commercial agency.

According to the 2003 annual report of Nanjing Zhongbei, the shareholders of Nanjing Zhongbei which hold an interest of 5% or more are Nanjing Proprietary State-owned Property Management Company (Holdings) Company (南京市國有資產經營(控股)公司) which owns an interest of 28.56% of the registered capital of Nanjing Zhongbei and Nanjing Public Utilities Proprietary Holding (Group) Company Limited (南京公用控股(集團)有限公司) which owns an interest of 5.81% of the registered capital of Nanjing Zhongbei.

Nanjing Zhongbei has nominated Zhao Wen (趙文) and Zhu De Xiang (朱德祥) as Directors. Both of them are non-executive Directors and they do not involve in the daily management of the Company.

As at the Latest Practicable Date, none of the shareholders of Nanjing Zhongbei has undertaken not to dispose of their respective shareholdings in Nanjing Zhongbei. Nanjing Zhongbei has undertaken to the Company and the Stock Exchange that, during the Lock-up Period, it will not, save as provided in Rule 13.18 of the GEM Listing Rules, (i) dispose of (nor enter into any agreement to dispose of) nor permit the registered holder to dispose of (or to enter into any agreement to dispose of) any of its equity interest in the Company; or (ii) otherwise create (nor enter into any agreement to create) nor permit the registered holder to create (or to enter into any agreement to create) any options, rights, interests or encumbrances in respect of any such interest.

None of the Directors and members of the senior management of the Company had any interests in Nanjing Zhongbei as at the Latest Practicable Date.

To the best of the Directors' knowledge, Nanjing Zhongbei and its associates have no business or interest that competes or may compete with the business of the Group and have no other conflict of interest with the Group pursuant to Rule 11.04 of the GEM Listing Rules.

GENERAL OVERVIEW OF THE GROUP

9. Huadong Technology is a joint stock limited liability company established in the PRC on 8 January 1993 and its A shares commenced listing on the Shenzhen Stock Exchange on 20 May 1997. Details of Huadong Technology as appeared in its 2003 annual report are set out below:

Registered capital	:	RMB359,157,356
Registration number of the business licence	:	3201911000044
Registered address	:	Block D03, Nanjing New and High Technology Development Zone
Legal representative	:	Zhao Jin Cheng (趙竟成)
Name of directors	:	Zhao Jing Cheng (趙竟成), Xu Sen (徐森), Chen Zhong Guo (陳忠國), Zhao Bao Lin (趙寶林), Wang Bao Ping (王保平), Wang Xiu Pu (王秀浦), Han Zhi Jun (韓之俊), Si Yun Cong (司雲聰), Xu Qing (徐清)
Principal banker	:	Industrial and Commercial Bank of China, Nanjing Xinjiekou Branch (中國工商銀行南京分行新街口支行)
Auditors	:	Nanjing Yonghua Certified Public Accountants (南京永華會計師事務所有限公司)
Stock code	:	000727

Huadong Technology is principally engaged in the business of the manufacture and sale of electronic vacuum device, lighting device, display device, new generation of electronic device and electronic materials and crystal device and provision of energy resources. As the Company is principally engaged in the provision and operation of video security system solutions, the business of Huadong Technology does not compete with that of the Company.

According to the 2003 annual report of Huadong Technology, the shareholder of Huadong Technology which holds an interest of 5% or more is Nanjing Huadong Electronic Group Company (南京華東電子集團公司) which owns an interest of 45.20% of the registered capital of Huadong Technology.

According to the 2003 annual report of Huadong Technology, Nanjing Huadong Electronic Group Company (南京華東電子集團公司) is a State-owned enterprise established in the PRC on 30 May 1991. It is principally engaged in the business of manufacture and sale of fluorescent powder, lightings, medical electronics, solar energy water heater, modules, devices of integrated systems and fire prevention products. It does not engage in any business which competes with the business of the Company.

Huadong Technology has nominated Zhao Jing Cheng(趙竟成)and Zhang Yin Qian(張銀千)as Directors. Both of them are non-executive Directors and they do not involve in the daily management of the Company.

As at the Latest Practicable Date, none of the shareholders of Huadong Technology has undertaken not to dispose of their respective shareholdings in Huadong Technology. Huadong Technology has undertaken to the Company and the Stock Exchange that, during the Lock-up Period, it will not, save as provided in Rule 13.18 of the GEM Listing Rules, (i) dispose of (nor enter into any agreement to dispose of) nor permit the registered holder to dispose of (or to enter into any agreement to dispose of) any of its equity interest in the Company; or (ii) otherwise create (nor enter into any agreement to create) nor permit the registered holder to create (or to enter into any agreement to create) any options, rights, interests or encumbrances in respect of any such interest.

None of the Directors and members of senior management of the Company had any interests in Huadong Technology as at the Latest Practicable Date.

To the best of the Directors' knowledge, Huadong Technology and its associates have no business or interest that competes or may compete with the business of the Group and have no other conflict of interest with the Group pursuant to Rule 11.04 of the GEM Listing Rules.

10. Liao Qiong (廖瓊) is a manager of the finance department of Sample Group and is directly interested in 3.58% of the registered capital of Sample Group, which in turn will be directly interested in 27.91% of the registered capital of the Company immediately after the completion of the Placing (without taking into account any Shares which

GENERAL OVERVIEW OF THE GROUP

may fall to be issued upon the exercise of any options granted under the Share Option Scheme). She is also one of the 21 other natural persons who are interested in 58.13% in aggregate of Sample Group (For details of the 21 other natural persons, please refer to note 1 above). Her total attributable shareholding interest in the Company will be approximately 1.0% immediately after the completion of the Placing (without taking into account any share which may fall to be issued upon the exercise of any options granted under the Share Option Scheme).

Liao Qiong (廖瓊) has undertaken to the Company and the Stock Exchange that she will not dispose of (nor enter into any agreement to dispose of) any of her equity interest in Sample Group for a period of 12 months from the Listing Date.

11. Sample Commerce City is a limited liability company established in the PRC on 1 December 1996.

Registered capital	:	RMB3 million
Registration number of the business licence	:	3201021001688
Registered address	:	454 Zhujiang Road, Xuanwu District, Nanjing
Legal representative	:	Guo Min Ke (郭明科)
Name of directors	:	Guo Ming Kei (郭明科)
Principal banker	:	Nanjing Commercial Bank Ji Ming Si Office (南京市商業銀行雞鳴寺支行)
Auditors	:	Jiangsu Su Cheng Certified Public Accountants (江蘇蘇盛會計師事務所)

The scope of business of Sample Commerce City is the sale of computers, computer accessories and consumable materials, electronic products and communication equipment (excluding ground reception unit for satellite), household appliances; venue letting; sale of merchandise, office appliances, ironmongery alternating current power, mechanical products, electrical appliances and machinery, building materials; design, production of and agent service for press and magazine, printed advertisement and gift advertisement; goods and accessories, warehousing, loading and unloading and transportation (applicable for operation by branches only).

Sample Commerce City is engaged in the business of commercial shops leasing. Since Sample Commerce City does not manufacture and sell any electronic products, the Company considers that the business of Sample Commerce City does not compete with that of the Company.

Sample Commerce City has undertaken to the Company and the Stock Exchange that, during the Lock-up Period, it will not, save as provided in Rule 13.18 of the GEM Listing Rules, (i) dispose of (nor enter into any agreement to dispose of) nor permit the registered holder to dispose of (or to enter into any agreement to dispose of) any of its equity interest in the Company; or (ii) otherwise create (nor enter into any agreement to create) nor permit the registered holder to create (or to enter into any agreement to create) any options, rights, interests or encumbrances in respect of any such interest.

Sample Group and Liao Qiong (廖瓊) are interested in 95% and 5% respectively of the registered capital of Sample Commerce City. Each of the shareholders of Sample Commerce City has undertaken to the Company and the Stock Exchange that it/she will not dispose of (nor enter into any agreement to dispose of) any of its/her equity interest in Sample Commerce City for a period of 12 months from the Listing Date.

To the best of the Directors' knowledge, Sample Commerce City and its associates have no business or interest that competes or may compete with the business of the Group and have no other conflict of interest with the Group pursuant to Rule 11.04 of the GEM Listing Rules.

12. Qi Tong Lin (祁同林) is directly interested in 2.00% of the registered capital of Sample Group, which in turn will be directly interested in 27.91% of the registered capital of the Company immediately after the completion of the Placing (without taking into account any Shares which may fall to be issued upon the exercise of any options granted under the Share Option Scheme). He is also a member of the senior management of the Company. He owns 5.00% equity interest in and is a director of Golden Dragon Software, a subsidiary of the Company. He is also one of the 21 other natural persons who are interested in 58.13% in aggregate of Sample Group (For detail of the 21 other natural persons, please refer to note 1 above). His total attributable shareholding interest in the

GENERAL OVERVIEW OF THE GROUP

Company will be approximately 0.56% immediately after the completion of the Placing (without taking into account any shares which may fall to be issued upon the exercise of any options granted under the Share Option Scheme).

Qi Tong Lin (祁同林) has undertaken to the Company and the Stock Exchange that he will not dispose of (nor enter into any agreement to dispose of) any of his equity interest in Sample Group for a period of 12 months from the Listing Date.

13. Sample Information System Engineering, owned as to 80% by the Company and as to 20% by Sample Group, is principally engaged in design and implementation of projects of the Group.

Golden Dragon Software, owned as to 95% by the Company and 5% by Qi Tong Lin (祁同林), is principally engaged in the development of software for the Group.

For further particulars of Sample Information System Engineering and Golden Dragon Software, please refer to the paragraph headed "History and development" under the section headed "General overview of the Group" of this prospectus.

14. Nanjing Daily was registered as a State-owned enterprise in the PRC on 13 May 1996.

Registered capital	:	RMB38.87 million
Registration number of the business licence	:	3201001009625
Registered address	:	No. 53 Jiefang Road, Baixia District, Nanjing
Legal representative	:	Tian Tao (田濤)
Principal banker	:	Industrial and Commercial Bank of China Jiefang Road Sub office (中國工商銀行 南京分行解放路分理處)
Auditors	:	Jiangsu Tianye Certified Public Accountants (江蘇天業會計師事務所)

The scope of business of Nanjing Daily is newspaper printing, publication and issue; printing, plate making, advertising and various business activities.

Pursuant to the Provisional Measures on the Administration of the Reduction of the State-owned Shares for Raising Public Security Funds (減持國有股募集社會保障資金管理暫行辦法) promulgated by the State Council on 12 June 2001, holders of state-owned shares of a joint stock limited company in the PRC shall offer for sale such number of state-owned shares which is equivalent to 10% of the funds to be raised under the initial public offering of the joint stock limited company. Accordingly, the 900,000 State-owned Shares originally held by Nanjing Daily were transferred to the Vendor, which will be converted to 900,000 H Shares and are offered for sale at the Placing Price under the Placing. Such H Shares will rank pari passu with the New H Shares in all respects. The proceeds from the sale of the Sale H Shares will be remitted to the National Social Security Fund (全國社會保障基金). The PRC legal advisers to the Company advise that both CSRC and SASAC have no objection to the above arrangement in relation to the Domestic Shares held by the Vendor in the Company.

According to the 2003 annual report of Nanjing Zhongbei, Nanjing Daily held 1.12% equity interest in Nanjing Zhongbei.

Tian Tao (田濤), the legal representative of Nanjing Daily, is a Supervisor.

Nanjing Daily had not appointed any representatives to the Board or involved in the management of the Company.

To the best of the Directors' knowledge, Nanjing Daily and its associates have no business or interest that competes or may compete with the business of the Group and have no other conflict of interest with the Group pursuant to Rule 11.04 of the GEM Listing Rules.

GENERAL OVERVIEW OF THE GROUP

15. Shanghai Common Data Technologies Company Limited (上海統一數據技術有限公司) was established in the PRC on 28 December 2001 with a registered capital of RMB900,000. It provides services to electronic, computer, software and telecommunication facilities sectors. It is also engaged in the sales of electronic products, computers and computer hardware, and telecommunication facilities. At the time of its establishment, Shanghai Common Data Technologies Company Limited (上海統一數據技術有限公司) was owned as to 60% by Golden Dragon Software, as to 14% by Huang Kun (黃昆), as to 14% by Du Yan (杜炎), as to 3% by Xu Yu Min (徐玉敏), as to 3% by Zheng Xin (鄭昕), as to 3% by Cai Dan (蔡丹) and as to 3% by Shi Chun Lei (施春雷). Its board of directors comprised Guo Ya Jun (郭亞軍), Fu Yu Qing (富煜清), Qi Tong Lin (祁同林), Huang Kun (黃昆) and Du Yan (杜炎); and Cai Dan (蔡丹) was its supervisor. For the year ended 31 December 2002, the net asset value, total turnover and net loss of Shanghai Common Data Technologies Company Limited (上海統一數據技術有限公司) were approximately RMB552,000, RMB120,000 and RMB348,000 respectively. Pursuant to seven share transfer agreements all dated 25 January 2003, Golden Dragon Software agreed to transfer all its equity interest in Shanghai Common Data Technologies Company Limited (上海統一數據技術有限公司) to Ye Yan Ming (葉燕銘) at a consideration of RMB540,000 whilst Huang Kun (黃昆), Du Yan (杜炎), Xu Yu Min (徐玉敏), Zheng Xin (鄭昕), Cai Dan (蔡丹) and Shi Chun Lei (施春雷) agreed to transfer all their respective equity interest in Shanghai Common Data Technologies Company Limited (上海統一數據技術有限公司) to Wang Jing Jing (王京菁) at a consideration of RMB126,000, RMB126,000, RMB27,000, RMB27,000, RMB27,000 and RMB27,000 respectively. The Directors consider that the considerations of the share transfers were fair and reasonable. Such transfers were approved by a resolution of shareholders' of Shanghai Common Data Technologies Company Limited (上海統一數據技術有限公司) dated 22 January 2003. As a result of the transfers, Shanghai Common Data Technologies Company Limited (上海統一數據技術有限公司) was owned as to 60% by Ye Yan Ming (葉燕銘) and as to 40% by Wang Jing Jing (王京菁). All the purchasers are Independent Third Parties.

At the time of its establishment, Shanghai Common Data Technologies Company Limited (上海統一數據技術有限公司) was an indirect subsidiary of the Company as it was owned as to 60% by Golden Dragon Software, a direct subsidiary of the Company which was owned as to 95% by the Company. After the share transfers pursuant to the seven share transfer agreements dated 25 January 2003, the Company no longer has any relationship with Shanghai Common Data Technologies Company Limited (上海統一數據技術有限公司). Such disposal was made because the Company intended to concentrate on its traffic and customs related business and the projects undertaken by Shanghai Common Data Technologies Company Limited (上海統一數據技術有限公司) were only in the procedural phase and still far from completion. The Company considered that the possibility to carry on the projects and meet the original target was far-reaching.

The PRC legal advisers to the Company advise that the Company had paid up the registered capital of each of its subsidiaries.

ORGANISATIONAL STRUCTURE

The Company has complied with the Company Law and its constitution since its incorporation. It holds members' general meeting, meetings of the boards of Directors and Supervisors on a regular basis, appoints general manager and set up an administrative and operational structure with natural persons for the implementation of its regulated operation. The members' general meeting is the highest authority of a joint stock company and represents the interests of, and protects the legal interests of all the shareholders. The Board of Directors represents the authority for operational decisions and accounts to the members' general meeting. The Board of Directors comprises 10 Directors who were elected in the members' general meeting, three of which are independent non-executive Directors. The Board of Directors has one chairman who is the legal representative of the Company. The board of Supervisors is the supervising authority of the Company and is responsible for exercising the supervisory functions over the Board of Directors, the general manager and other senior management members. The board of Supervisors comprises 5 Supervisors, of which one is the representative elected by the staff. The general manager, who is employed and discharged of by the Board of Directors, is in charge of the ordinary routine works of production, operation and administration and accounts to the Board of Directors.

GENERAL OVERVIEW OF THE GROUP

The organisational structure of the Group are as follows:

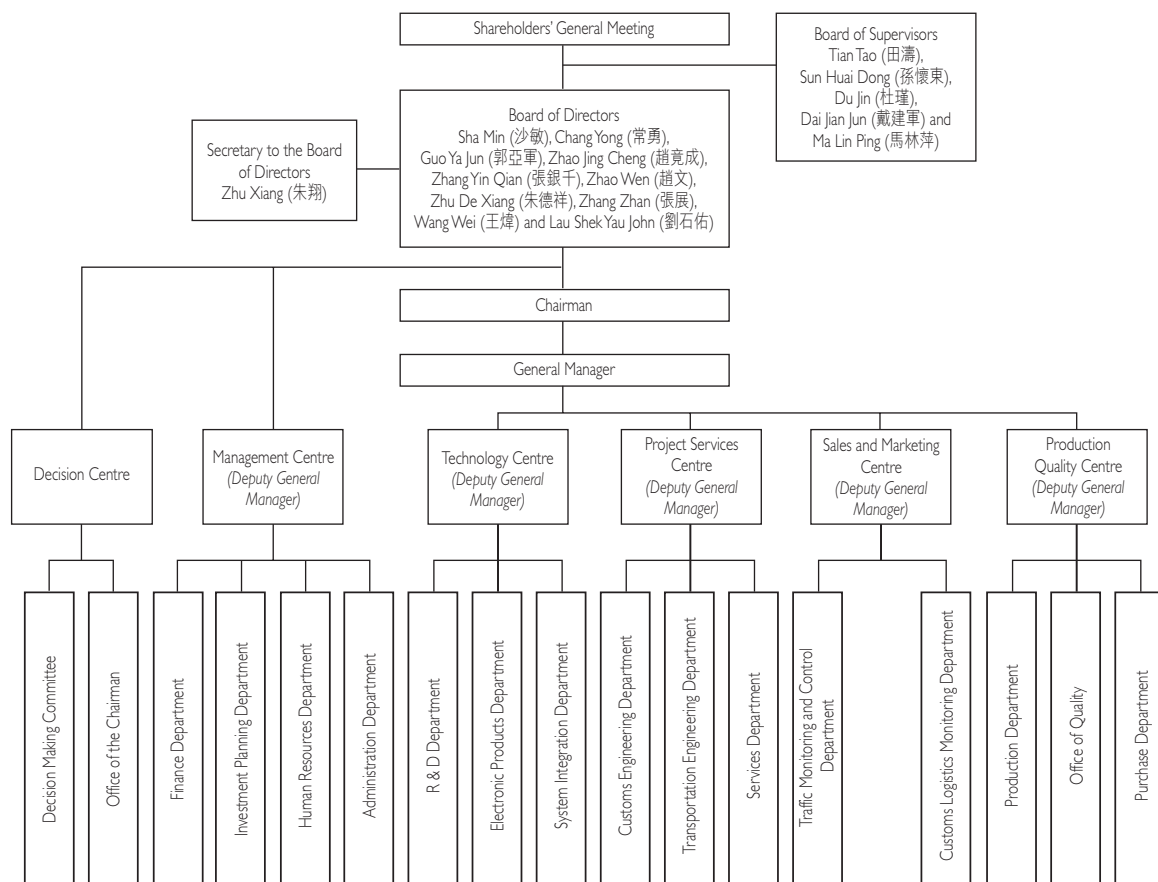

HISTORY AND DEVELOPMENT

Sample System, the predecessor of the Company, was established as a limited liability company on 30 December 1997. Upon establishment, it had a registered capital of RMB5 million and was held as to approximately 20% by Sample Industry, approximately 20% by Sample Commerce City, approximately 40% by Hu Jia Yong (胡家永) and approximately 20% by Qi Tong Lin (祁同林). Its legal representative was Chang Yong (常勇). According to a capital verification report (寧會審所驗 (1997) 064號) dated 25 December 1997 and an agreement entered into between Sample Industry, Sample Commerce City, Hu Jia Yong (胡家永) and Qi Tong Lin (祁同林) dated 24 December 1997, the RMB1 million capital injection by Sample Industry was in the form of technological product known as Automatic Transformer Substation Video Monitoring and Control System (無人值班變電站遠程視頻監控系統). The technological product was used to develop video security system solutions for the urban elevator sector. The Directors advise that the Group had ceased to develop video security system solutions for the urban elevator sector since January 2001 in view of the limited potential for further market development in the sector. The Directors consider that the capital injection of the technological product in the amount of RMB1 million was fair and reasonable as the agreement dated 24 December 1997 was reached between Sample Industry, Sample Commerce City, Hu Jia Yong (胡家永) and Qi Tong Lin (祁同林) after arm's length negotiation with reference to an asset valuation report (寧審所資 [1997] 660號) dated 12 December 1997 issued by a PRC registered asset valuer, an Independent Third Party. At that time, Sample System was principally engaged in the business of R&D, distribution and sale of traffic monitoring

GENERAL OVERVIEW OF THE GROUP

and control products and Chang Yong (常勇) was a Director. The following was the then structure of the registered capital of Sample System:

Name of shareholder	Capital contribution (RMB thousand)	Percentage of equity interest (%)
Sample Industry	1,000	20.00
Sample Commerce City	1,000	20.00
Hu Jia Yong (胡家永) (Note 1)	2,000	40.00
Qi Tong Lin (祁同林) (Note 2)	1,000	20.00
Total	<u>5,000</u>	<u>100.00</u>

Notes:

- Hu Jia Yong (胡家永) was interested in 40% equity interest of Sample System at the time of its establishment. He transferred such equity interest to Sample Industry pursuant to an agreement dated 10 December 1999 entered into between Sample Industry, Sample Commerce City, Nanjing Zhongbei, Hu Jia Yong (胡家永), Qi Tong Lin (祁同林) and Sha Min (沙敏). The Directors confirm that Hu Jia Yong (胡家永) was also interested in 11.76% equity interest of Sample Group during the period from 25 January 1998 to 28 May 2002. He has transferred such equity interest to Cai Long (蔡龍) pursuant to an agreement dated 28 May 2002.

Save that Hu Jia Yong (胡家永) was a shareholder of Sample System from 30 December 1997 to 28 February 2000 and a shareholder of Sample Group from 25 January 1998 to 28 May 2002, he has no relationship with the Company.

- Qi Tong Lin (祁同林) is a member of the senior management of the Company who is directly interested in 2% of the registered capital of Sample Group, which in turn will be directly interested in approximately 27.91% of the Company immediately after the completion of the Placing (without taking into account any Shares which may fall to be issued upon the exercise of any options granted under the Share Option Scheme). He is also a shareholder of Golden Dragon Software, a subsidiary of the Company.

At that time, Sample Industry was held as to approximately 9.41% by Sha Min (沙敏), approximately 8.24% by Sun Huai Dong (孫懷東), approximately 8.24% by Chang Yong (常勇), approximately 8.82% by Guo Ya Jun (郭亞軍), approximately 11.77% by Qi Tong Lin (祁同林), approximately 5.88% by Dai Xiao Yu (戴曉玉), approximately 4.71% by Li Mang (李忙), approximately 8.82% by Wu Jian Qiao (伍建橋), approximately 5.88% by Tao Yan Juan, approximately 9.41% by Gu Qun (顧群), approximately 7.06% by Zhang Xiao Chun (張效春) and approximately 11.76% by Hu Jia Yong (胡家永). The board of Sample Industry comprised Sun Huai Dong (孫懷東), Chang Yong (常勇), Sha Min (沙敏), Guo Ya Jun (郭亞軍) and Hu Jia Yong (胡家永). According to the business licence of Sample Industry, Sample Industry was engaged in the business of: research, manufacture and sales of electronic products and communication facilities (excluding ground reception unit for satellites), instruments and meters, medical equipment; technological development and technical services of computer hardware and software; sales of general merchandises, construction materials, hardware and electronic appliances (excluding bicycles), electrical hardware, and electrical equipment; export of electronic products and communication facilities, instruments and meters, and medical equipment manufactured by the company; and import of raw materials, machinery and equipment, instruments and meters, and components required by the company for its manufacturing and R&D. As advised by the Directors, Sample Industry became an investment holding company in December 2000.

GENERAL OVERVIEW OF THE GROUP

At the same time, Sample Commerce City was held as to 95% by Sample Industry and 5% by Guo Ya Jun (郭亞軍) and its sole executive director was Chang Yong (常勇). According to the business licence of Sample Commerce City, Sample Commerce City was principally engaged in the business of: sales, development, service and advisory service of computers and components and consumption materials, electronic products and communication (excluding ground reception unit for satellites), home electrical appliances, and medical equipment; renting; sales of general merchandises, office stationery, hardware and electronic appliances, machinery and electrical products, electrical hardware, and construction materials; design, production, agency of newspapers and magazines, advertising of publications, advertising of gifts; and courier of goods, storage, loading, and transport services (can only be operated by branches).

On 10 December 1999, Sample Industry, Sample Commerce City, Hu Jia Yong (胡家永), Qi Tong Lin (祁同林), Nanjing Zhongbei and Sha Min (沙敏) entered into a share transfer and capital increase agreement pursuant to which they agreed, inter alia, that (i) Hu Jia Yong (胡家永) should transfer the RMB2 million equity interest held by him in Sample System (representing 40% of the registered capital of Sample System at that time) to Sample Industry at a consideration of RMB2 million; (ii) Qi Tong Lin (祁同林) should transfer the RMB230,000 equity interest held by him in Sample System (representing 4.6% of the registered capital of Sample System at that time) to Sample Industry at a consideration of RMB230,000; (iii) Qi Tong Lin (祁同林) should transfer the RMB390,000 equity interest held by him in Sample System (representing 7.8% of the registered capital of Sample System at that time) to Sample Commerce City at a consideration of RMB390,000; and (iv) Qi Tong Lin (祁同林) should transfer the RMB380,000 equity interest held by him in Sample System (representing 7.6% of the registered capital of Sample System at that time) to Sha Min (沙敏) at a consideration of RMB380,000. According to a capital verification report (蘇盛會驗 [2000]010-2) dated 31 January 2000, Sample System's then net asset value before the share transfer was approximately RMB5.1 million. The Directors confirm that the Company intended to list its shares on a stock exchange in the PRC as A shares in or around year 1999. To the best of the Directors' knowledge at that time, prior to year 2000, no A shares companies listed have individual natural person as a promoter. Therefore, at that time, Hu Jia Yong (胡家永) and Qi Tong Lin (祁同林) transferred all their respective interests in Sample System for the purpose of reorganizing Sample System in order to conform to such norm prevailing at that moment.

Pursuant to the share transfer and capital increase agreement dated 10 December 1999, Sample Industry, Sample Commerce City, Hu Jia Yong (胡家永), Qi Tong Lin (祁同林), Nanjing Zhongbei and Sha Min (沙敏) also agreed to increase the registered capital of Sample System from RMB5 million to RMB38 million which should be satisfied by way of injection of intangible asset and cash as to RMB13.24 million by Sample Industry and cash as to RMB19.76 million by Nanjing Zhongbei. According to a capital verification report (蘇盛會驗 (2000)010-2) dated 31 January 2000, the RMB13.24 million capital injection by Sample Industry consisted of intangible assets in the form of non-patented technology (as to RMB8.3 million) and RMB4.94 million cash. The non-patented technology was valued by a PRC registered asset valuer, an Independent Third Party, in an asset valuation report (寧永會評報(1999)057), at RMB13.9 million. The non-patented technology was applied to the Urban Elevator Monitoring and Testing Alarm System (城市電梯監測報警系統) and the Procuratorate Evidence Displaying System (檢察院示證系統), which were the main video security system solutions of the urban elevator sector and the procuratorial sector of the Group's business respectively. The Directors advise that the Group had ceased to develop video security system solutions for the urban elevator sector and the procuratorial sector since January 2001 and December 2002 respectively in view of the limited potential for further market development in these two sectors. The Directors consider that the valuation of RMB8.3 million in respect of the injection of the non-patented technology was fair and reasonable as the agreement was reached between Sample Commerce City, Nanjing Zhongbei, Sha Min (沙敏) and Sample Industry pursuant to a technology injection agreement of the same date after arm's length negotiation with reference to the asset

GENERAL OVERVIEW OF THE GROUP

valuation report. Hu Jia Yong (胡家永) and Qi Tong Lin (祁同林) were not parties to the technology injection agreement dated 10 December 1999 despite their being, at that time, shareholders of Sample System registered with the Nanjing Administration for Industry and Commerce (南京市工商行政管理局) because they had agreed to dispose of all of their respective interest in the registered capital of Sample System pursuant to the share transfer and capital increase agreement of the same date. As the valuation of the non-patented technology would affect the respective interest of Nanjing Zhongbei and Sha Min (沙敏), who had agreed to acquire interest in Sample System pursuant to the share transfer and capital increase agreement dated 10 December 1999, they were made parties to the technology injection agreement.

On the same day, a shareholders' meeting of Sample System was held at which, among other matters, resolutions were passed to approve (i) the increase of the registered capital of Sample System as set out above; (ii) the transfer of equity interest as set out above; (iii) the change of company name from Sample System to Sample Computer Technology; and (iv) the election of Sha Min (沙敏), Chang Yong (常勇), Guo Ya Jun (郭亞軍), Wang Yi (王毅) and Zhao Wen (趙文) as Directors. The changes were duly registered with the Nanjing Administration for Industry and Commerce (南京市工商行政管理局) and a business licence was issued on 28 February 2000. The following was the structure of the registered capital of Sample Computer Technology after the change in registered capital from RMB5 million to RMB38 million:

Name of shareholder	Capital contribution (RMB thousand)	Approximate percentage of equity interest (%)
Nanjing Zhongbei	19,760	52.00
Sample Industry	16,470	43.34
Sample Commerce City	1,390	3.66
Sha Min (沙敏) (Note)	380	1.00
	38,000	100.00
Total	38,000	100.00

Note: Sha Min (沙敏) is an executive Director and the chairman of the Company.

On 11 March 2000, Sample Information System Engineering was established by Sample Computer Technology and Huadong Electronics with a registered capital of RMB22 million which was owned as to 43% by Huadong Electronics and as to 57% by Sample Computer Technology. The registered capital of Sample Information System Engineering was fully paid up by Huadong Electronics on 26 January 2000 and Sample Computer Technology on 31 January 2000 and 29 February 2000. According to a capital verification report (寧永會二驗字(2000)011號) dated 4 March 2000, out of the RMB12.54 million contributed by Sample Computer Technology, RMB3.13 million was in the form of tangible assets comprising stocks, equipment and motor vehicles; and RMB7 million was in the form of technology which was applied to Digital ePolice System (數碼電子警察系統) and Highway Security Checkpoint Monitoring and Control System (公路治安卡口監控系統), which were the main video security system solutions for the traffic monitoring and control sector. The tangible assets and the technology were valued at approximately RMB3.77 million and RMB11.2 million respectively according to an asset valuation report (寧永會評報(2000)第052號) dated 10 February 2000. The Directors consider that the capital injection of the tangible assets in the amount of RMB3.13 million and the technology in the amount of RMB7 million were fair and reasonable as the valuations were reached between Sample Computer Technology and Huadong Electronics after arm's length negotiation with reference

GENERAL OVERVIEW OF THE GROUP

to the asset valuation report. In October 2000, Huadong Electronics agreed to transfer its 43% equity interest in Sample Information System Engineering to Sample Industry at a consideration of RMB9.46 million. In November 2001, Sample Industry agreed to transfer its 23% equity interest in Sample Information System Engineering to Sample Computer Technology at a consideration of RMB5.06 million. After the completion of the transfers, Sample Information System Engineering was owned as to 80% by Sample Computer Technology and as to 20% by Sample Industry. Sample Information System Engineering is principally engaged in design, supervision and implementation of computer network systems and industry automation projects. The Company controls the composition of the board of directors of Sample Information System Engineering. As at the Latest Practicable Date, the directors of Sample Information System Engineering were Sha Min (沙敏), Chang Yong (常勇) and Guo Ya Jun (郭亞軍) who are also executive Directors and were all nominated by the Company.

On 16 June 2000, Sample Industry and Nanjing Zhongbei entered into an agreement pursuant to which Nanjing Zhongbei agreed to transfer its RMB9.625 million equity interest in Sample Computer Technology to Sample Industry at a consideration of RMB9.625 million as Nanjing Zhongbei had no intention to become the controlling shareholder of the Company and involve actively in the daily management of the Company. According to a capital verification report (蘇盛會驗 [2000]010-2) dated 31 January 2000, the net asset value of Sample System as at 27 January 2000 was approximately RMB38.1 million. The transfer was approved by a resolution of the shareholders of Sample Computer Technology on the same day. The following was the structure of the registered capital of Sample Computer Technology after the transfer:

Name of shareholder	Capital contribution (RMB thousand)	Approximate percentage of equity interest (%)
Sample Industry	26,095	68.67
Nanjing Zhongbei	10,135	26.67
Sample Commerce City	1,390	3.66
Sha Min (沙敏)	380	1.00
Total	38,000	100.00

On 30 July 2000, Sample Industry, Huadong Electronics and Nanjing Daily entered into an agreement pursuant to which Sample Industry agreed to transfer its RMB10.135 million equity interest in Sample Computer Technology (representing approximately 26.7% of the registered capital of Sample Computer Technology) to Huadong Electronics at a consideration of RMB12 million. Sample Industry also agreed to transfer its RMB760,000 equity interest in Sample Computer Technology (representing 2% of the registered capital of Sample Computer Technology) to Nanjing Daily at a consideration of RMB1.8 million. According to an accountant's report (寧永會五審字 (2000)096) dated 10 December 2000, the audited total assets of Sample Computer Technology as at 30 September 2000 was approximately RMB65.7 million. To the best of the Directors' knowledge, the reason for the transfers was that Huadong Electronics regarded Sample Computer Technology as an investment which could diversify its business and Nanjing Daily was confident in the prospects of ITS industry. On the same day, resolutions were passed by the shareholders of Sample Computer Technology approving, inter alia, (i) the transfer; (ii) the election of Zhao Jing Cheng (趙竟成) as director; and (iii) the resignation of Wang Yi (王毅) from directorship of Sample Computer Technology. The changes made pursuant to the resolutions dated 16 June 2000 and 30 July 2000 were duly registered with the Nanjing Administration for Industry and Commerce (南京市工商行政管理局) and a business licence was issued on 10 August 2000.

GENERAL OVERVIEW OF THE GROUP

Subsequent to the passing of the resolutions, the board of directors of Sample Computer Technology comprised Sha Min (沙敏), Chang Yong (常勇), Guo Ya Jun (郭亞軍), Zhao Jing Cheng (趙竟成) and Zhao Wen (趙文). The following was the structure of the registered capital of Sample Computer Technology after such transfer:

Name of shareholder	Capital contribution (RMB thousand)	Approximate percentage of equity interest (%)
Sample Industry	15,200	40.00
Nanjing Zhongbei	10,135	26.67
Huadong Electronics (Note 1)	10,135	26.67
Sample Commerce City	1,390	3.66
Nanjing Daily (Note 1)	760	2.00
Sha Min (沙敏) (Note 2)	380	1.00
Total	38,000	100.00

Notes:

- For the background of Huadong Electronics and Nanjing Daily, please refer to the paragraph headed "Shareholding structure" under this section.
- Sha Min (沙敏) is an executive Director and the chairman of the Company.

Sample Computer Technology was converted to a joint stock limited company in the name of the Company. Such conversion was approved by the shareholders of Sample Computer Technology pursuant to a resolution dated 12 October 2000 and was approved by the Nanjing People's Government (南京市人民政府) pursuant to an approval document (寧政覆[2000] 119號) dated 28 December 2000. The conversion was registered with the Nanjing Administration for Industry and Commerce (南京市工商行政管理局) and a business licence was issued on 29 December 2000. By a shareholders' resolution of the Company dated 29 December 2000, Sha Min (沙敏), Chang Yong (常勇), Guo Ya Jun (郭亞軍), Zhao Jing Cheng (趙竟成), Zhang Yin Qian (張銀千), Zhao Wen (趙文), Zhu De Xiang (朱德祥), Zhang Zhan (張展) and Huang Wei were elected as Directors. The registered capital of the Company was RMB45 million divided into 45 million Domestic Shares of RMB1.00 each. The following was the shareholding structure of the Company immediately after the conversion of Sample Computer Technology into a joint stock limited company in the name of the Company:

Name of shareholder	Capital contribution (RMB thousand)	Approximate shareholding percentage (%)
Sample Industry	18,000	40.00
Nanjing Zhongbei	12,000	26.67
Huadong Electronics	12,000	26.67
Sample Commerce City	1,650	3.66
Nanjing Daily	900	2.00
Sha Min (沙敏)	450	1.00
Total	45,000	100.00

GENERAL OVERVIEW OF THE GROUP

Pursuant to an approval (寧上管辦(2000)002號) issued by the Management Office for the Reorganisation and Listing of Enterprises in Nanjing (南京企業改制上市管理辦公室) dated 9 November 2000, Huadong Electronics changed its name to Huadong Technology with a registered capital of RMB313,738,600.

Pursuant to a resolution of the Shareholders dated 26 February 2001, the registered address of the Company was changed. The change of registered address of the Company to Room 103, Building No. 1, Ruan Jian Chuang Ye Zhong Xin, High Technology Development Region, Nanjing City, Jiangsu Province, PRC was duly registered with the Nanjing Administration for Industry and Commerce (南京市工商行政管理局) and a business licence was issued on 2 March 2001. On 29 February 2001, the Company was permitted for business operation in the Nanjing High and New Technology Industry Development Zone (南京高新技術產業開發區) with the approval (寧高管內字(2001) 22號) from the Administration Committee of the Nanjing High and New Technology Industry Development Zone (南京高新技術產業開發區管理委員會).

By a shareholders' resolution of the Company dated 10 November 2001, Wang Wei (王偉) was elected as a Director in replacement of Huang Wei.

On 7 November 2001, Golden Dragon Software was established by the Company and Qi Tong Lin (祁同林) with a registered capital of RMB6 million. It was owned as to 95% by the Company and 5% by Qi Tong Lin (祁同林). The registered capital of Golden Dragon Software was fully paid up by the Company and Qi Tong Lin (祁同林) on 5 November 2001 and 2 November 2001 respectively. The Company set up Golden Dragon Software with Qi Tong Lin (祁同林) because Qi Tong Lin (祁同林) was a member of the senior management team and a long-term staff of the Company and the Company regarded Qi Tong Lin (祁同林) as an authority in the technology field. The principal business and products of Golden Dragon Software are software development, technology consultation service, software for data management of highway vehicle monitoring and customs control software. The Company controls the composition of the board of directors of Golden Dragon Software. The directors of Golden Dragon Software are Sha Min (沙敏), Chang Yong (常勇) and Qi Tong Lin (祁同林). Sha Min (沙敏) and Chang Yong (常勇) are executive Directors and Qi Tong Lin (祁同林) is a member of the senior management of the Company. They were all nominated by the Company.

On 10 March 2001, Guo Min Ke (郭明科) was elected as the sole executive director of Sample Commerce City. Pursuant to an equity transfer agreement dated 17 June 2002, Guo Ya Jun (郭亞軍) transferred his 5% equity interest in the registered capital of Sample Commerce City to Liao Qiong (廖瓊).

On 20 August 2002, Sample Industry's registered capital was increased to RMB33 million. Sha Min (沙敏), Chang Yong (常勇), Guo Min Ke (郭明科), Zhu Xiao Hui (朱曉暉) and Cai Long (蔡龍) were elected as directors of Sample Industry. For the structure of registered capital of Sample Industry after the increase of capital, please refer to the paragraph headed "Shareholding structure" under this section. On the same day, Sample Industry changed its name to Sample Group with a registered capital of RMB33 million.

BUSINESS OVERVIEW

The Group is a major developer and provider of video security system solutions in the PRC targeting on government authorities. Currently, its system solutions are designated for use in (i) the traffic monitoring and control sector; and (ii) the customs logistics monitoring sector in the PRC.

The video technologies adopted by the Group include video data capturing, transmission and processing technologies which involve the utilisation of system solution software to enable, among others, digital video recording, phototaking, video data compression and decompression, various types of image processing and identification and data analyses. The video security system solutions developed by the Group involve the application of those technologies for security, law-enforcement and administrative and regulatory purposes in (i) the traffic monitoring and control sector; and (ii) the customs logistics monitoring sector in the PRC. All system solutions provided by the Group, except for (i) certain ready-made system solutions components purchased from third parties; and (ii) the related computer products as set out in the paragraph headed "Sales of related computer products" under this section, are developed by the Group.

The Group endeavours to become a prominent provider and operator of video security system solutions in (i) the traffic monitoring and control sector; and (ii) the customs logistics monitoring sector in the PRC. In July 2001, the Company was recognised as a Software Enterprise (軟件企業) by the Jiangsu Information Industry Department (江蘇省信息產業廳). In August of the same year, the Company was also recognised as a Key High and New Technology Enterprise (重點高新技術企業) by the Torch High Technology Industry Development Centre of the Ministry of Science and Technology (科學技術部火炬高技術產業中心). In November 2002, the Company was granted the Qualification Certificate for Construction Enterprises (Grade three) (建築業企業資質證書(三級)) by the Jiangsu Construction Department (江蘇省建設廳) and was qualified to undertake Intelligent Construction works with contract values of RMB6 million or below. In November 2003, the Company was granted the Qualification Certificate for Computer Information System Integration (Grade three) (計算機信息系統集成資質證書(三級)) and was qualified to be capable of undertaking computer information system constructions independently for small and medium enterprises and co-operatively for large enterprises. In December of the same year, the Company was recognised as an Advanced National Information Industry System Organisation (全國信息產業系統先進集體) by the Ministry of Personnel of the PRC (中華人民共和國人事部) and the MII.

As far as the PRC legal advisers to the Company are aware, the Group has obtained the required licences, permits and certificates to operate its current business in the PRC since its establishment and that they are not aware of other restrictions imposed by the relevant authorities on the business currently carried on by the Group. The relevant licences, permits and certificates obtained by the Group include: (i) the Qualification Certificate for Technology Trading (南京市技術貿易資格證書) issued by the Nanjing Technology Marketing Management Office (南京技術市場管理辦公室) on 21 June 2001; (ii) the Software Enterprise Recognition Certificate (軟件企業認定證書) issued by the Jiangsu Information Industry Department (江蘇省信息產業廳) on 28 July 2001; (iii) the Qualification Certificate for the Design and Construction of Security Preventive System (Works) of Jiangsu Province (Grade one) (江蘇省安全技術防範系統(工程)設計施工資格證書(一級)) issued by the Jiangsu Public Security Department Technology Protection Office (江蘇省公安廳技術防範辦公室) on 1 January 2004; (iv) the Certificate for the Qualification of Construction Companies (Grade three) (建築業企業資質證書(三級)) issued by the Jiangsu Construction Department (江蘇省建設廳) on 19 November 2002; and (v) the Qualification Certificate for Computer Information System Integration (Grade three) (計算機信息系統集成資質證書(三級)) issued by the MII on 26 November 2003.

BUSINESS OF THE GROUP

REVENUE MODEL

Currently, the Group's revenue is mainly derived from the provision of video security system solutions to its customers on a project basis. Some of the projects undertaken by the Group are obtained through tenders. Generally, the Company would bid for projects in response to tender invitations by the relevant PRC government authorities. The prices of the Group's system solutions would generally be finalised at the end of the bidding process in accordance with the general standard of placing competitive bids.

The Group also sells some related computer products to its customers. Such related computer products include monitors, cables and wiring, digital cameras, servers and workstations, which are general hardware products required for the Group's video security system solutions. The Group would provide and sell such related computer products to its customers upon request in order to facilitate their usage of the Group's video security system solutions.

Recently, the Group has also commenced operating video security system solutions for some provincial/municipal governments in the PRC. The Directors consider that, as the Group participates in the operation of its system solutions for provincial/municipal governments in the PRC, management fees generated from such participation will broaden the Group's revenue base and provide a recurring revenue stream for the Group.

Upon the successful implementation of the operation of video security system solutions for some provincial/municipal governments in the PRC, the Group's revenue stream will comprise: (i) income derived from the provision of video security system solutions; (ii) management fees derived from the operation of video security system solutions; and (iii) income derived from sales of related computer products. Items (i) and (ii) may be recurring or non-recurring whilst item (iii) is non-recurring in nature.

BUSINESS OF THE GROUP

TENDERING AND PRODUCTION PROCESSES

The tendering procedure adopted by the Company is illustrated in the following chart:

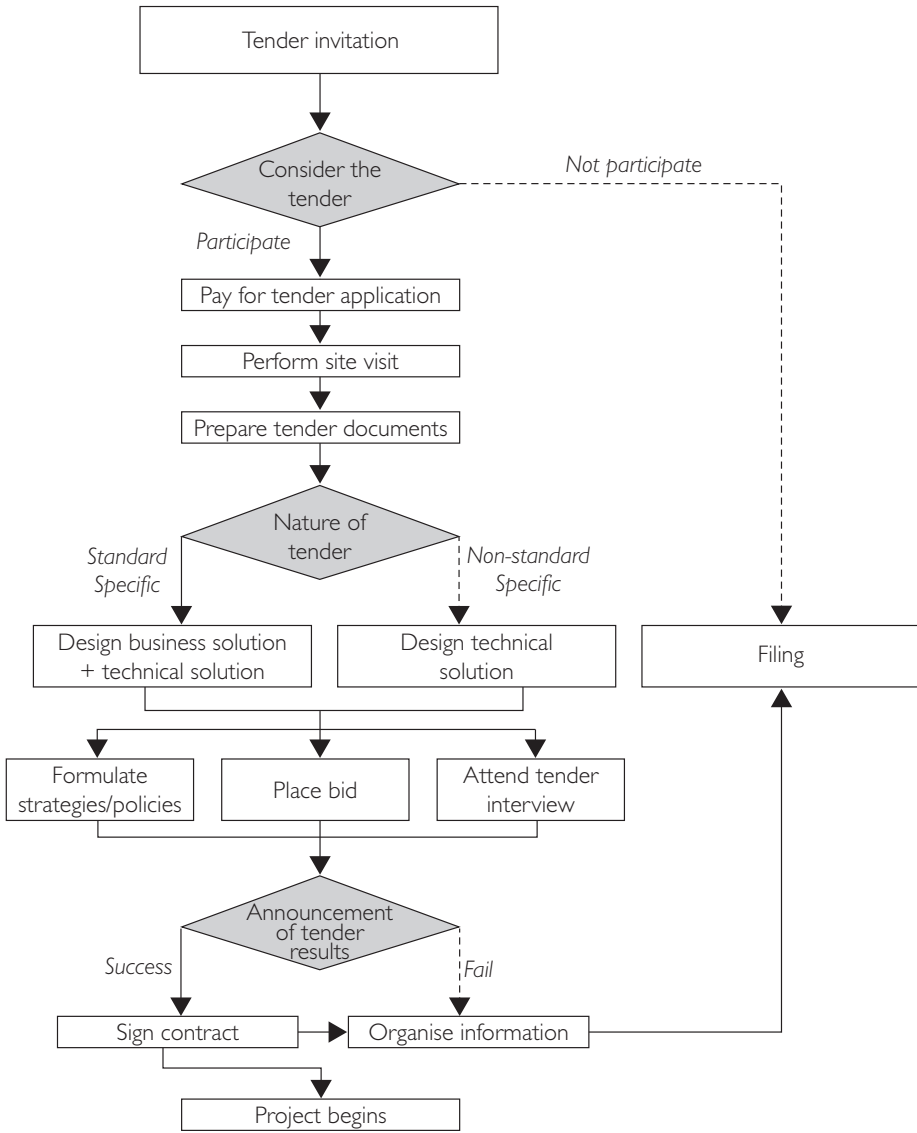

The following diagram illustrates the production process of the Group's video security system solutions after it successfully wins a bid:

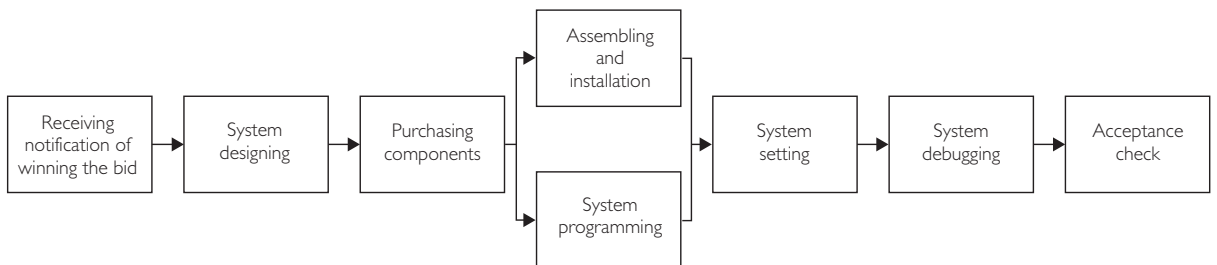

Receiving notification of winning the bid

After winning the tender and receiving notification, the Group will enter into a contract with the relevant authorities to undertake the project.

System designing

The technology centre, project services centre, sales and marketing centre and production quality centre of the Group are involved in system designing. These centres may conduct site visits and meetings with the authorities concerned to discuss the requirements and/or functionality of the system solution. The final design of the system solution plans will be submitted to the authorities concerned for approval.

Purchasing components

The Group's main procurement items include digital cameras, computers and computer hardware, graphic cards, television sets, light-emitting diode, cases, racks, and cables and wires. The Group procures components required for its tendered projects on a project-by-project basis, except for some generic items, such as cases, racks, and cables and wires.

Assembling and installation

The actual on-site/installation work is implemented by the project services centre of the Group. The Group assigns a project team to supervise the progress of the project. This project team is normally led by a project team leader supported by approximately 5-10 team members depending on the size and timetable of the project.

System programming

The technology centre of the Group is responsible for the programming of systems, which can be conducted with assembling and installation during the production process. The programs will be designed and tested at the headquarters of the Group before installed into the client's system.

System setting

The technology centre of the Group assigns IT technicians to the client's site to install the system who are responsible for compiling the appropriate default setting of the system for the authorities concerned.

System debugging

After setting the system, the IT technicians perform a series of debugging tests to check for any error in system programming.

BUSINESS OF THE GROUP

Acceptance check

Upon satisfaction of the operation of the system, the authorities concerned will confirm and sign off the receipt and usage of the system solution.

PRODUCTION FACILITIES

The Group's headquarters are currently located at Rooms 701-3, 702-2 and 702-3, Cheng Chang Development Zone, Jiangsu Software Park, No. 168 Longpan Zhong Road, Nanjing City, Jiangsu Province, the PRC. Currently, the Group's accounting department, sales and marketing department, R&D department and management are all located in the headquarters. The production (including system designing, system programming) of the Group's video security system solutions are also conducted in the headquarters.

The Company acquired a parcel of land from the Nanjing Land Resources Bureau (南京市國土資源局) in August 2003 with a total site area of approximately 50,117 sq.m. at a consideration of approximately RMB6.0 million. The Group intends to develop the Sample Science and Technology Park (三寶科技產業園) (the "Technology Park") on the parcel of land and the headquarters of the Group will also be relocated to the Technology Park. The current construction comprises a software R&D building, a main office building and a residential and catering building and have a total gross floor area of approximately 13,814 sq.m.. The Directors anticipate that the construction will be completed in or around June 2004.

Software R&D building

The software R&D building is a 3-storey building with a total gross floor area of approximately 4,080 sq.m. and will be occupied by the Group's transportation engineering department, customs engineering department and system integration department. A software testing laboratory, an engineering centre and a logistics centre will also be located in the building. The Directors expect that the furnished building would be able to accommodate 300 to 500 technicians and staff. This represents the maximum capacity of personnels that the R&D software building will be able to accommodate. As set out in the paragraph headed "Implementation plan - Allocation of human resources" under the section headed "Statement of business objectives" in this prospectus, the Directors intend to expand the Group's R&D team and the technical support service team with 85 and 88 members respectively by the end of 2006 and the Directors consider that the capacity of the R&D software building will be sufficient for the Group's intended expansion of R&D staff and technical support service team during the Forward Looking Period. Given the possible business opportunities that may arise in the future, the Group may continue to expand its R&D activities and may employ additional technicians and R&D staff after the Forward Looking Period. The Directors consider that, given such possible further expansion in R&D activities and human resources after the Forward Looking Period, the Group should reserve sufficient office area and space in the Technology Park and the Group will not require to incur extra time or costs to search for and purchase or lease additional office space. Accordingly, the Directors consider that reserving sufficient office areas now in the Technology Park for possible future development and expansion would be beneficial to the Group. This also enables the Group to be more flexible in recruiting extra personnels or purchasing additional equipment or facilities for different departments when it considers necessary. The Directors currently intend not to lease out the excess spaces of the software R&D building and will allocate these vacant spaces to its existing staff.

BUSINESS OF THE GROUP

Main office building

The main office building is a 4-storey building with a total gross floor area of approximately 4,890 sq.m. and will comprise a management centre, a sale and marketing centre, an exhibition centre and a conference centre. The management department, human resources department, finance department and investment department will also be located in the main office building. The Directors expect that the main office building would be able to accommodate approximately 200 staff. This represents the maximum number of personnel that the main office building will be able to accommodate. As set out in the paragraph headed "Implementation plan - Allocation of human resources" under the section headed "Statement of business objectives", the Directors intend to expand the Group's non-technical personnel to 102 (50 for management and general administration and 52 for sales and marketing) by the end of 2006 and the Directors consider that the capacity of the main office building will be sufficient for the Group's staff expansion during the Forward Looking Period.

As the headquarters of the Group will be relocated to the Technology Park after the completion of the construction, which is currently expected to be in or around June 2004, the Directors consider that the headquarters of the Group should provide sufficient space for the existing employees of different departments and also provide with excess areas to be utilised for further expansion in the future. The Directors consider that, after the listing of the H Shares on GEM, the Group's business and operational scale will be enhanced and therefore it is necessary to reserve excess office space for possible expansion in human resources and/or production facilities during or after the Forward Looking Period. The Directors currently do not intend to lease out the excess spaces of the main office building and will allocate these vacant spaces to its existing staff.

Residential and catering building

The residential and catering building is a 3-storey building with a total gross floor area of approximately 4,844 sq.m. and will comprise a catering centre, a leisure centre and staff quarters.

The Directors anticipate that the construction will be completed in or around June 2004 with an expected total construction cost of approximately RMB49.0 million. The Directors consider that, given the Group's net cash position as at 31 December 2003, the construction costs could be financed by the Group's internal resources and the Directors do not intend to finance the construction costs by any of the proceeds from the Placing of the New H Shares. As at the Latest Practicable Date, the Group had contracted an amount of approximately RMB28.3 million for the construction of the Technology Park, out of which approximately RMB28.2 million had been incurred and paid by the Group as at 30 April 2004, such sum mainly comprised fees for the initial site inspection and design, administration fees and costs for the construction of buildings, offices and other infrastructure. The balance of approximately RMB0.1 million represents the capital commitment of the Group which was contracted but not provided for in the Group's financial statements as at 31 December 2003. The expected remaining construction cost to be incurred in the amount of approximately RMB20.7 million will be applied to the construction of infrastructure, setting up plumbing and electricity systems, installation of equipment, interior and exterior design of buildings and other miscellaneous site projects.

Upon completion of the construction of the Technology Park, the Group will be subject to a property registration fee (房產登記費) of RMB4,000 and a property floor area survey charge (房屋面積勘測費) of RMB3.5 per sq.m. of the property's gross floor area.

PROVISION OF VIDEO SECURITY SYSTEM SOLUTIONS

Traffic monitoring and control sector

The Group has been engaged in the transport monitoring and control sector since the introduction of its Red Light Overshoot Automatic Record System (also known as ePolice) (闖紅燈自動記錄系統(又名電子警察)) since 1999. In respect of urban traffic construction, the Ministry of Public Security of the PRC (中華人民共和國公安部) announced the implementation of the Safe Road (平安大道) campaign and Clear Way Project (暢通工程) in April 1999 and February 2000 respectively. Since then, the Group has been engaged in the corresponding R&D with a view to meeting the requirements of the State sector in respect of the above-mentioned projects. The scope of applications of the video security system solutions of the Group has also been extended from general requirements at urban road junctions to inter-province traffic networks. The first system solution of the Company, the ePolice, was originally used at urban road junctions. As the demand for intelligent transportation system grows, the Company commenced to develop products that can be used for inter-province traffic network, namely the Highway Vehicle Intelligent Monitoring and Recording System (also known as Highway Checkpoint Inspection System) (公路車輛智能化監測與記錄系統(又名公路卡口系統)).

The Recommendation in relation to the Implementation of National City Road Traffic Management (Clear Way Project) (關於實施全國城市道路交通管理「暢通工程」意見) was issued jointly by the Ministry of Public Security of the PRC (中華人民共和國公安部) and the Ministry of Construction of the PRC (中華人民共和國建設部) on 16 February 2000. The recommendation requires that specified zones in the PRC would need to implement “Clear Way Project” to improve the traffic management of highways. These zones include municipalities directly supervised by the PRC central government, provincial capital, provincial capital of autonomous regions and cities under direct planning by the State. Altogether 36 major cities, two prefecture-level cities and two county-level cities as confirmed by each province/autonomous region in the PRC are included under the Clear Way Project.

In April 1999, the Ministry of Public Security of the PRC (中華人民共和國公安部) demanded that the whole country should implement the “Safe Road Project”. The motives and aims of the “Safe Project” are:

- establishing road patrolling system;
- establishing scientific and effective monitoring mechanism;
- enforcing vehicles to comply with traffic rules and regulations;
- resolving traffic congestion;
- ensuring that no severe traffic accident will happen;
- enabling relevant PRC government departments to identify and provide support when accident happens; and
- improving visibility of traffic signals and directories.

BUSINESS OF THE GROUP

The Company's products/system solutions, such as the ePolice and the Highway Checkpoint Inspection System, can assist PRC government security departments to manage traffic through 24-hour remote monitoring, record keeping, abnormality identification and, where applicable, subsequent fining and prosecution. The Police Inspection and Reporting Post Information System and City Traffic Command Centre System, on the other hand, has increased the level of efficiency in monitoring and control of traffic management. The Company's products/system solutions effectively reduce the necessary manpower and time in the police day to day task and form an integral part of the traffic monitoring and control mechanism to ensure compliance of traffic rules and regulations.

Red Light Overshoot Automatic Recording System (also known as ePolice) (闖紅燈自動記錄系統(又名電子警察))

The Company commenced the development of the Red Light Overshoot Automatic Recording System in November 1998. The Company launched the ePolice in April 1999, which was designed for 24-hour monitoring and reporting on speeding vehicles or vehicles overshooting red light at urban road junctions. The existing model of ePolice has been modified substantially since its initial launch in 1999. Closed-circuit Televisions ("CCTV") have replaced portable digital cameras as the key image capturing equipment and the system has been upgraded to support internet access. ePolice can automatically take still images of law-violating vehicles by adopting digital image processing technology, network communication technology and multi-phase inspection technology. The product has been adopted by public security departments in 49 different cities in 14 provinces (Anhui, Fujian, Hebei, Henan, Hubei, Jilin, Jiangsu, Jiangxi, Liaoning, Shandong, Shanxi, Sichuan, Yunnan and Zhejiang) and 2 municipalities directly under the central government (Beijing and Chongqing) of the PRC.

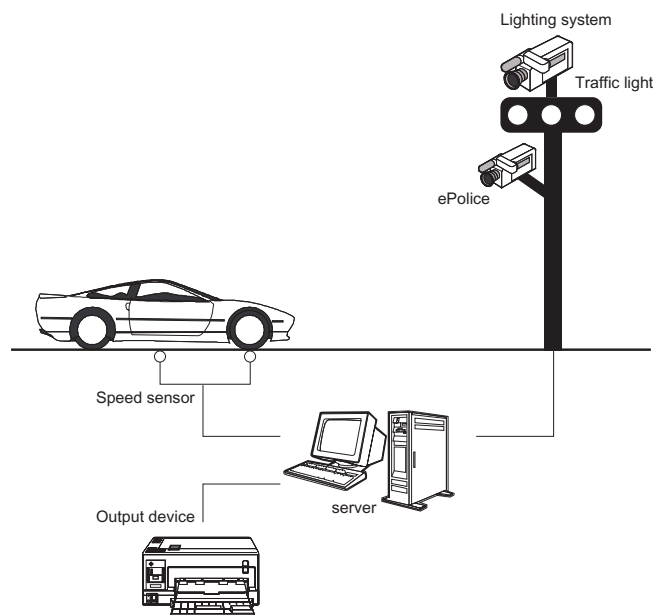

The structure of ePolice



An ePolice installed in Nanjing

BUSINESS OF THE GROUP

An ePolice generally consists of (i) one or more CCTVs for still image capturing; (ii) coils embedded in the ground at road junctions as sensors to record the speed of vehicles, (iii) linkages between the traffic light system and the server; (iv) a lighting system that facilitate the capture of images at night or in poor weather conditions; and (v) system hardware and software for image processing/identification and interfacing purposes. Images regarding rules violation captured by ePolice are used by the PRC public security authorities to prosecute or take the appropriate actions against violators. In areas where Internet services are available, the information captured by the CCTV will be transferred to servers located at the relevant police station or monitoring post via the Internet. For those areas in which Internet services are not available, the information obtained by ePolice is stored in detachable hardware that would be collected manually on-site. The Directors believe that, with the increasing availability of Internet service in the PRC in the future, less manpower will be required to operate the system.

Highway Vehicle Intelligent Monitoring and Recording System (also known as Highway Checkpoint Inspection System) (公路車輛智能化監測與記錄系統(又名公路卡口系統))

The Highway Vehicle Intelligent Monitoring and Recording System is designed for 24-hour monitoring and recording of motoring vehicles in inter-province traffic networks comprising city gateways, freeways and other major sections of roads. The Company launched this system in September 1998, which can effectively identify and capture still and moving images of law-violating vehicles and vehicles on wanted lists including overloaded vehicles, speeding vehicles and vehicles which flee from accident. The system is also capable of performing search and re-play functions on the moving images captured. The Directors believe that with such capabilities, the system plays a role in the Safe Road (平安大道) campaign promoted by the Ministry of Public Security.

Generally, a Highway Vehicle Intelligent Monitoring and Recording System consists of (i) CCTV that capture continuous image; (ii) system software for image processing; (iii) system software for vehicle licence plate recognition; (iv) lighting system with light sensor to facilitate the capturing of video; (v) software for compression of information captured by the system; and (vi) system network that links with the control centre of the local public security bureau.



Recording equipment located in City Highway



Search and Re-play interface

City Traffic Command Centre System (城市交通指揮中心系統)

It is a stated principle of the Clear Way Project (暢通工程) that traffic command centre should be integrated into the overall urban development plans. The City Traffic Command Centre System is an integrated city traffic command solution developed with a view to satisfying that principle. The Company launched the City Traffic Command Centre System in November 2000.

BUSINESS OF THE GROUP

The system utilises advanced technologies in the areas of electronic map, image processing, GPS and GIS. It integrates such technologies with the operations of traffic light controls and the operations of the Sub-unit of the Public Security Road Safety Bureau (公安道路安全部支隊) to divert traffic flow and identify law-violating vehicles. Various separate systems have been linked and logically managed and organised by computer communication networks. Different sub-systems have also been linked via the city electronic map platform to provide city geographic information and traffic management information on an integrated basis. As a result, information sharing, united command, logical redeployment are realised and an intelligent transportation management and traffic accident emergency support system is established. The major functions of the system include: (i) recording the movement of vehicles into/out of the cities; (ii) identifying the specific location of a vehicle within the city by GPS and GIS technologies; (iii) remote monitoring of the traffic of different areas; and (iv) alerting officials when abnormalities are identified.

The following diagram depicts the structure of a City Traffic Command Centre System:

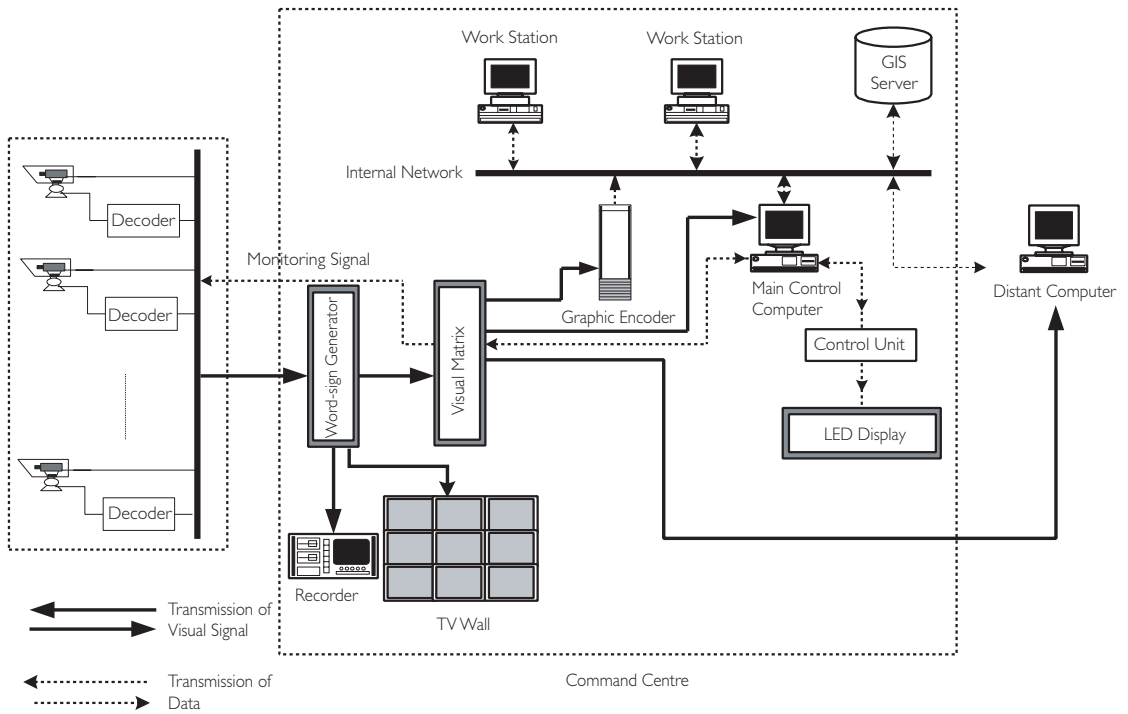

The City Traffic Command Centre System is generally integrated with ePolice. The images/video signals captured by the ePolice (or other similar systems) will be transmitted to the command centre. After processing by the “Word-sign Generator” (a software that helps add texts, such as dates, times and locations, to the images/video captured), all images captured from different places in the city will be displayed on the TV wall of the command centre sequentially on real-time basis. To facilitate subsequent enquiries and/or prosecutions (if necessary), all images/video signals will be recorded and backed up for storage. Through the “Visual Matrix” (a software platform that determines the appropriate flow of data of images captured), the processed images/video data will be transmitted to the main control computer and the “Graphic Encoder”, where images/video data will be compressed and encrypted for transmission in the internal network. Based on the pre-specified criteria, (i) alert signals will be displayed on the light emitting diode display inside the command centre to alert officials of the occurrences of specific events; (ii) reports will be generated for follow-up actions; and (iii) various viewpoints of the image/video capturing device can be adjusted/controlled.

BUSINESS OF THE GROUP

Police Inspection and Reporting Post Information Management System (警務查報站信息管理系統)

The Police Inspection and Reporting Post Information Management System is a system solution designed for public security authorities to monitor flow of motor vehicles. Police inspection and reporting posts are set up at major roads in the urban area by PRC municipal public security authorities. The system carries out real time supervision through (i) capturing images of vehicles; (ii) calculating speed of vehicles; (iii) identifying models of vehicles; and (iv) identifying vehicles' registration numbers on licence plates. This system enables the police inspection and reporting posts to share information of the surveillance database and stolen vehicle database of the command centre. Once any wanted or stolen vehicles that matched with the database information are identified, the system will automatically alert the relevant police inspection and reporting posts to take appropriate action. The system was launched by the Company in September 2003.

The following diagram depicts the structure of a Police Inspection and Reporting Post Information Management System:

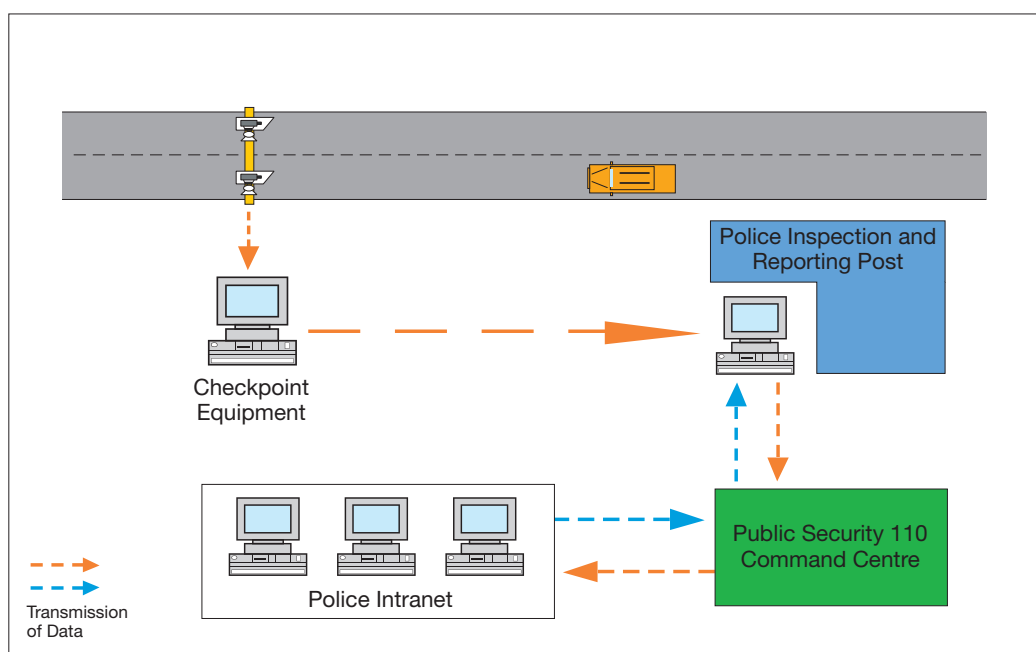

Mobile Vehicles Inspection System (移動式車輛緝查系統)

Leveraging on its experience gained from developing ePolice and the Highway Vehicle Intelligent Monitoring and Recording System, the Group has developed the Mobile Vehicles Inspection System, which can be installed in a police patrol car for automatically capturing and recording still images of passing vehicles, whether the police patrol car is stationary or in motion. The system adopts image identification technologies together with vehicle database and communication equipment to identify law-violating vehicles and "blacklisted" vehicles (e.g. speeding vehicles not observing traffic signals, stolen vehicles, vehicles on the wanted list, vehicles fleeing from accidents). The system can be programmed to automatically focus on a specific road or area and record the licence plates of passing vehicles. The system is able to recognise the licence plate numbers being captured and verify the numbers with the built-in "blacklisted" vehicle database. The system will alert a signal whenever it detects licence plate numbers that are equivalent or similar to those contained in the database. Subject to manual verification that the detected vehicles are "blacklisted", the police will immediately take action to trace the vehicles and arrest the drivers. The Company launched this system in June 2003. The

BUSINESS OF THE GROUP

Directors believe that the system provides effective technological support for the implementation of the Clear Way Project (暢通工程) and Safe Road (平安大道) campaign promoted by the Ministry of Public Security of the PRC (中華人民共和國公安部) and other traffic management authorities, and the system also reduces the time and manpower of the police to verify blacklisted vehicles.

The following diagram depicts the structure of a Mobile Vehicles Inspection System:

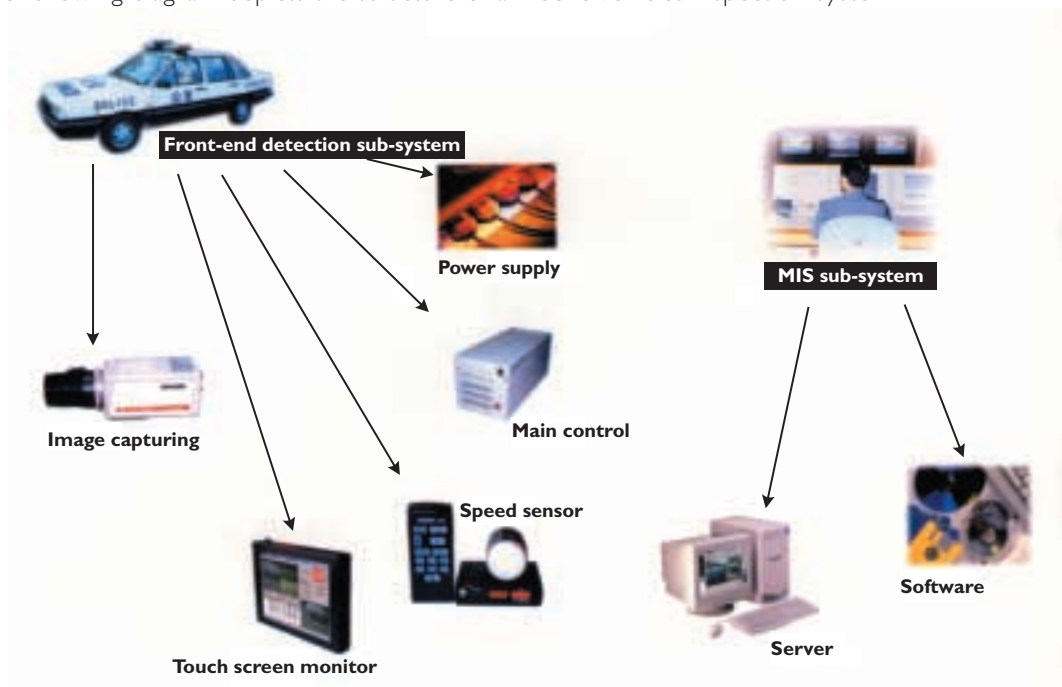

Captured image of speeding vehicle



Captured image of law-violating vehicle

Customs logistics monitoring sector

The Group has also been engaged in the customs logistics monitoring sector since July 1999 when the Group and the Nanjing Customs (南京海關) jointly developed the Customs Checkpoint Automatic Inspection System (海關關口自動查驗系統). Leveraging on the expertise and knowledge attained from the joint development of the Customs Checkpoint Automatic Inspection System (海關關口自動查驗系統), the Group subsequently developed another system in relation to the customs logistics monitoring sector called Customs Logistics Monitoring System (海關物流監控系統).

BUSINESS OF THE GROUP

Customs Logistics Monitoring System (海關物流監控系統)

The Customs Logistics Monitoring System is a system in relation to customs logistics monitoring sector and was developed by the Group. It contains a centralised database shared by local customs bureaus and facilitates the local customs bureaus to download, process and analyse the data and information contained in the centralised database. Through the Group's visual identification and RFID technologies, and together with the weighing system, the Customs Logistics Monitoring System can capture details of cargos, including reference numbers, weights and clearance times, and monitor the logistics and movement of cargos within the customs area. When a loaded vehicle stops at the inspection checkpoint, the registered licence number of the vehicle, colour of the vehicle and reference number of the containers will be recognised and recorded automatically by the Group's visual identification and RFID technologies on a real-time basis as image signals. At the same time, the weight of the loaded vehicle will also be automatically measured and recorded by the weighing system. The image signals and the weight information will be converted into data and transmitted to the central system for comparison with the information declared to the customs. The Customs Logistics Monitoring System will be alerted if it identifies any false declaration and unreported cargoes and the cargoes concerned will be diverted to a special route for manual inspection by the staff of the local customs bureaus. Accordingly, the Customs Logistics Monitoring System saves time and effort and also automates some daily routine and manual workflow including (i) inspection of the cargo details; and (ii) verification of the weights of cargos against those declared to the local customs bureaus. The Customs Logistics Monitoring System can cater for imports, exports, in-transits and miscellaneous cargos.

In addition to automating the daily routine workflow of the local customs bureaus, the Directors believe that the Customs Logistics Monitoring System also helps to reduce manual error, the Directors consider that this system enables the local customs bureaus to expedite the monitoring process and, therefore, reduce manual error and minimise possible fraudulent actions.

The Company had successfully applied the Customs Logistics Monitoring System to undertaken certain projects in relation to the customs logistics monitoring sector during the Track Record Period. Such projects are (i) Customs Export Processing Zone Project; and (ii) Customs International Wharf Project, details of which are described below:

Customs Export Processing Zone Project (海關出口加工區工程)

EPZs are specially enclosed areas supervised by the General Customs Administration of the PRC (中華人民共和國海關總署). Business activities inside the EPZs are restricted, such that only export processing, freight transport and storage related to processing activities for enterprises located in EPZs are permitted. The major objectives of establishing EPZs are to promote exports and prevent any illegal sale of duty-free imports of raw materials. VAT is not levied on any activities taken place within the EPZs and imports are tax-exempted.

Customs Export Processing Zone Project is developed based on the Company's Customs Logistics Monitoring System with a supplemental data capturing system. Information captured through visual identification and RFID technologies will be automatically uploaded to the database of the local customs bureaus for management and analysis purposes. The Company commenced to launch and distribute this project in August 2000 and through this project, the format of reports declared and submitted by transportation companies to the customs authorities of the EPZs are standardised and therefore this project reduces documentary and manual work.

BUSINESS OF THE GROUP

The following diagram depicts the structure of the Customs Export Processing Zone Project:

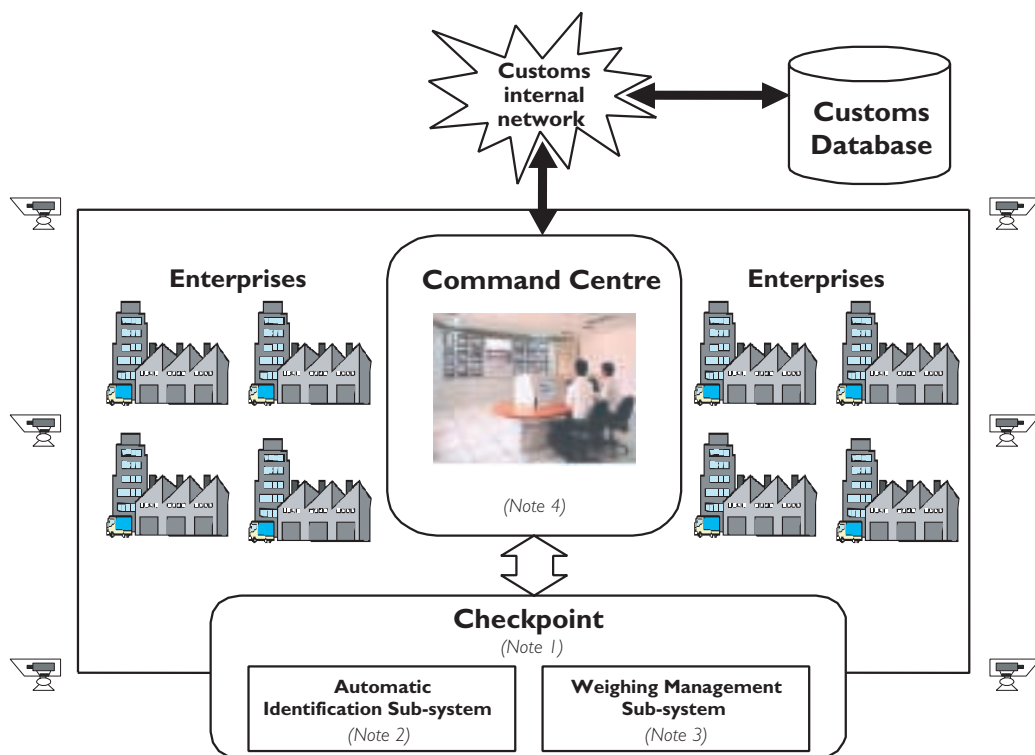

Notes:

1. Checkpoint is located at the entrance of the EPZ. Any vehicles and/or visitors must get through the checkpoints before entering into the EPZ.
2. The Automatic Identification Sub-system (自動識別系統) is a sub-system of the Company's Customs Logistics Monitoring System. It captures and identifies the images of vehicles' licence plates and cargos. The image signals will be converted into data and transmitted to the command centre of the EPZ.
3. The Weighing Management Sub-system (地磅管理系統) is a sub-system of the Company's Customs Logistics Monitoring System. It measures the weight of the loaded vehicle. The data will be transmitted to the command centre of the EPZ.
4. The command centre is responsible for monitoring vehicles and cargos in and out of the EPZ. By verifying the information detected by the systems against that declared by the enterprises inside the EPZ, the local customs bureaus can effectively identify any tax-evading activities.

There were 25 EPZs in the PRC in 2002 and the Group had entered into and subsequently completed 12 projects for these EPZs, representing approximately 50% market share. By the end of 2003, there were 38 EPZs and the Group had procured and completed 19 projects for these EPZs, representing 50% market share. The 19 key customs checkpoints that adopted the Company's Customs Logistics Monitoring System are listed below:

1. Nanjing Export Processing Zone (南京出口加工區)
2. Kunshan Export Processing Zone (崑山出口加工區)
3. Jiangsu Nantong Export Processing Zone (江蘇南通出口加工區)

BUSINESS OF THE GROUP

4. Wuxi Export Processing Zone (無錫出口加工區)
5. Suzhou Industrial Park Export Processing Zone (蘇州工業園出口加工區)
6. Suzhou New District Export Processing Zone (蘇州新區出口加工區)
7. Zhenjiang Export Processing Zone (鎮江出口加工區)
8. Wuhu Export Processing Zone (蕪湖出口加工區)
9. Dalian Export Processing Zone (大連出口加工區)
10. Tianjin Export Processing Zone (天津出口加工區)
11. Beijing Tianzhu Export Processing Zone (北京天竺出口加工區)
12. Qinghuangdao Export Processing Zone (秦皇島出口加工區)
13. Zhengzhou Export Processing Zone (鄭州出口加工區)
14. Xi'an Economy and Technology Development Zone Export Processing Zone (西安經濟技術開發區出口加工區)
15. Zhejiang Jiaying Export Processing Zone (浙江嘉興出口加工區)
16. Xiamen Export Processing Zone (廈門出口加工區)
17. Wuhan Export Processing Zone (武漢出口加工區)
18. Shenzhen Export Processing Zone (深圳出口加工區)
19. Beihai Export Processing Zone (北海出口加工區)

Customs International Wharf Project (海關國際碼頭工程)

Customs International Wharf Project is another type of customs logistics monitoring project undertaken by the Company for local customs bureaus to monitor the logistics and movement of cargos within the wharf areas which enhances the efficiency in recording and retrieving relevant information of the cargos. The Company's Customs Logistics Monitoring System is the underlying module of the project and is supported by other sub-systems, namely Automatic Identification Sub-system (自動識別系統), Barcode Reading and Printing Sub-system (條形碼閱讀及打印系統), Weighing Management Sub-system (地磅管理系統), Passage Management Sub-system (通道管理系統) and Statistics Enquiry Sub-system (查詢統計系統). Details of these sub-systems and their operations are depicted in the diagram below:

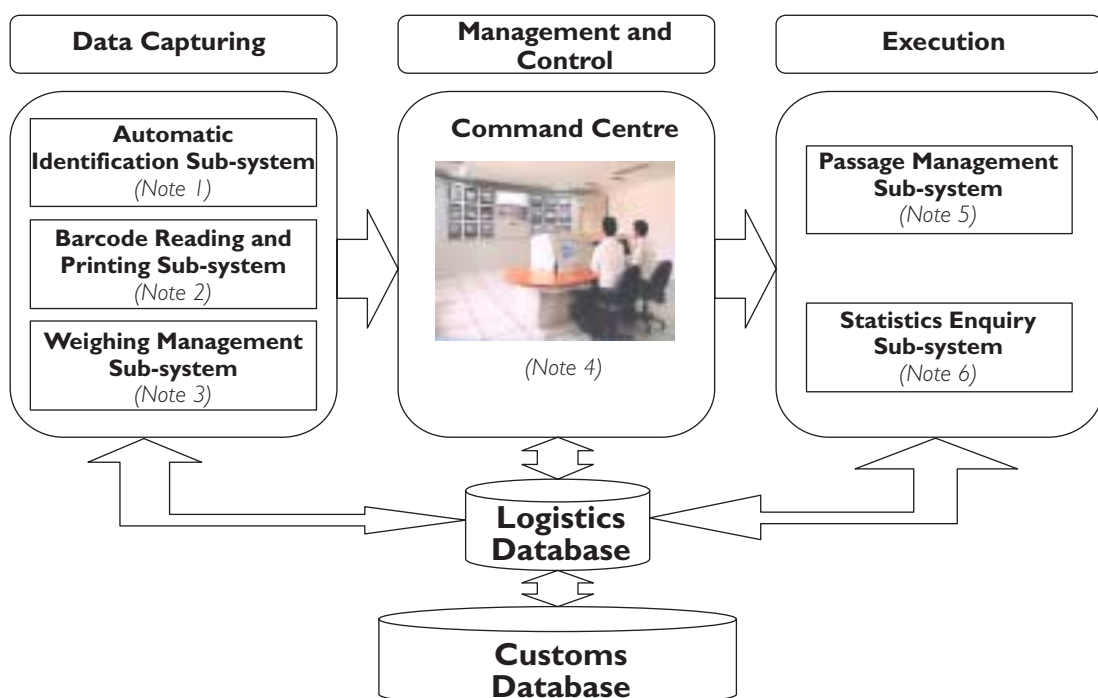

BUSINESS OF THE GROUP

Notes:

1. The Automatic Identification Sub-system (自動識別系統) captures and identifies images of vehicles' licence plates and cargos. The image signals will be converted into data and transmitted to the command centre of the wharf.
2. Information, including (i) registered numbers of vehicles; (ii) weights of vehicles; and (iii) weights of cargos, are stored in a tag labelled with a barcode. The Barcode Reading and Printing Sub-system (條形碼閱讀及打印系統) recognises the barcodes and generate electronic signals. The signals will be converted into electronic reports and displayed in one of the panels in the command centre of the wharf.
3. The Weighing Management Sub-system (地磅管理系統) measures the weights of the loaded vehicles. The data will be transmitted to the command centre of the wharf.
4. The command centre is responsible for the monitoring of cargos in and out of the wharf and control of the logistics of cargos inside the wharf.
5. The Passage Management Sub-system (通道管理系統) captures information of cargos for customs' inspection and statistical analyses.



Passage Management Sub-system



Passage Management Sub-system interface

6. The Statistic Enquiry Sub-system (查詢統計系統) enables customs authorities to obtain information of cargos in and out the passages of the wharf at any time and retrieve any relevant information for decision making.

The Customs International Wharf Project increases the level of automation of the operation of wharfs and the efficiency in customs logistics monitoring and therefore reduces manual error. The Group has undertaken such project since July 2000. Up to 31 December 2003, the Group had undertaken three such projects for Xiamen Customs (廈門海關), Nanjing Customs (南京海關) and Dalian Customs (大連海關).

Other sectors

The Group was also involved in the provision of video security system solutions for the procuratorial sector in the PRC. In July 1999, the Group began to engage in the sector by developing the Procuratorate Criminal Case Evidence-displaying System (檢察機關刑事案件法庭示證系統) with the People's Procuratorate of Jiangsu province (江蘇省人民檢察院). The system helps edit and arrange pictures and/or photographs of evidences to be demonstrated in courts in the sequence that follows the prosecutors' schedule. This system passed the inspection and assessment of the Supreme People's Procuratorate (最高人民檢察院) and was recommended by the General Office of the Supreme People's Procuratorate (最高人民檢察院辦公廳) to procuratorates across the PRC. By the end of 2002, the system was adopted by the procuratorates of 18 different provinces and municipalities namely Hubei, Inner Mongolia, Heilongjiang, Shanxi, Anhui, Jiangsu, Shandong, Guangdong, Henan, Hebei, Shanxi, Jilin, Guansu, Jiangxi, Fujian, Hunan, Beijing and Liaoning in the PRC. The Group was also involved in the provision of video security system solutions for the urban elevator sector in the PRC. The Group had developed Urban Elevator Monitoring and Testing Alarm System (城市電梯監測報警管理系統) which was a main video security system solution for this sector but the Group ceased to develop other system solutions for this sector since January 2001.

BUSINESS OF THE GROUP

As compared to the Group's business in the traffic monitoring and control sector and the customs logistics monitoring sector, the Directors believe that the businesses in the procuratorial sector and the urban elevator sector have limited potential for further market development. After the Group had succeeded in the development of several video security system solutions for (i) the traffic monitoring and control sector and (ii) the customs logistics monitoring sector, the Directors consider that the focus on the procuratorial sector and the urban elevator sector should be relinquished as the profit margin for each of these two sectors are relatively low (approximately 25%) compared to those of the other sectors (approximately 40%) and there is limited room for further market penetration. Accordingly, the Group re-allocated its resources to the development and provision of video security system solutions for other sectors. In December 2002, the Group disposed of the Procuratorate Evidence Displaying System (檢察院示證系統) and the Urban Elevator Monitoring and Testing Alarm System (城市電梯監測報警管理系統), with net book values of approximately RMB2.4 million and RMB1.0 million respectively to Southeast University Science Park Company Limited (東大科技園股份有限公司), an Independent Third Party, for a consideration of approximately RMB5.8 million and RMB2.5 million respectively, which was based on the capitalised cost of the Group's technologies recorded in 1999. Southeast University Science Park Company Limited (東大科技園股份有限公司) is a joint stock limited company registered with the Administration of Industry and Commerce of Jiangsu Province (江蘇省工商行政管理局) and is engaged, amongst others, in the provision of risk investment, security investment, asset management; R&D of hi-tech technologies, technology transfer, technology advisory services and manufacturing of corresponding products; construction of science and technology park and domestic trading in the PRC. Such disposals, subsequently, brought a gain of approximately RMB4.4 million to the Group in 2002.

The Group has not been engaged in the provision of any on-going after-sales services or maintenance services in support of its video security system solutions for the procuratorial sector and the urban elevator sector after the sale of these two sectors of the business.

The financial information in relation to the procuratorial sector of business of the Group for the year ended 31 December 2002 (without taking into account the gain on disposal of the Procuratorate Evidence Displaying System (檢察院示證系統)) is shown as follows:

	Year ended 31 December 2002*
Net asset value (RMB'000)	—
Percentage to net asset value of the Group	—
Total turnover (RMB'000)	1,319
Percentage to total turnover of the Group	2.12%
Net profit (RMB'000)	301
Percentage to net profit of the Group	2.40%

* the procuratorial sector of business was sold in December 2002

OPERATION OF VIDEO SECURITY SYSTEM SOLUTIONS

Other than focusing on the provision of video security products/system solutions, the Company has also expanded the scope of its business by becoming an operator of certain of its system solutions in the traffic monitoring and control sector. The Directors believe that the government provincial/municipal authorities in smaller cities (such as those in the western region) in the PRC might prefer leasing to purchasing the traffic

BUSINESS OF THE GROUP

monitoring and control system solutions of the Group. To cater for the needs of such authorities, the Group has begun to lease certain of its system solutions to those authorities on the basis that the Group retains ownership of the system solutions leased and the Group receives rental/management fees for managing and operating the same. The said rental/management fees would be derived from fines imposed on law-violating vehicles that are successfully prosecuted.

The Company entered into an arrangement with the Yizheng City Traffic Police Sub-unit (儀征市交巡警支隊) ("Yizheng Traffic Police") in March 2003 to jointly operate ePolices in Yizheng city of Jiangsu province. Pursuant to the agreement, the Company was responsible for all the capital investment, including the installation of ePolices and the operation maintenance and upgrading of the same. The Group would assign its staff to Yizheng city to carry out the work. Management fees (being the agreed portion of the total fines received by Yizheng Traffic Police) would be received by the Company on a quarterly basis. No revenue of management fees in relation to such co-operation had been recognised for the Track Record Period. For the four months ended 30 April 2004, the Group had generated a revenue of approximately RMB96,000 thereon. On 22 November 2003, the Company entered into another similar agreement with the Jintan City Public Securities Bureau (金壇市公安局). The arrangements are similar to those set out in the agreement with Jiangsu Traffic Police, under which Jintan City Public Securities Bureau is required to repay to the Company all the capital investment it incurs before the Company is entitled to share a portion of the total fines with the Jintan City Public Securities Bureau.

The Directors believe that such co-operation with different provincial and municipal authorities would enable the Group to generate a recurring revenue stream to finance its expansion and the Group will continue to explore similar opportunities to operate such centres in the PRC. It is also the intention of the Group to apply a portion of the net proceeds from the Placing of the New H Shares in R&D after the listing on GEM to capitalise on the potential and prospects of the video security market and the expected demand for their system solutions. Accordingly, upon successful development of new system solutions or upgrade version of the existing system solutions, the Group will determine which mode of business (provision and/or operation) to be adopted and implemented for those system solutions.

SALES OF RELATED COMPUTER PRODUCTS

The Group also sells some related computer products to its customers. Such related computer products include monitors, cables and wiring, digital cameras, servers and workstations, which are general hardware products required for the Group's video security system solutions. The Group would provide and sell such related computer products to its customers upon request in order to facilitate their usage of the Group's video security system solutions. The Directors consider that the sale of the related computer products can (i) serve as a value-added service to existing customers; (ii) provide opportunities for the Company to identify potential customers; (iii) minimise the cost of carrying inventory and reduce the possibility of its inventory becoming obsolete and the purchase cost of its raw material through bulk purchase; and (iv) minimise the risk of incompatibility with the video security system products/system solutions of the Group.

The Directors believe that the sale of related computer products will remain as a complementary business of the Company. For each of the three years ended 31 December 2003, sales of related computer products amounted to approximately RMB7.0 million, RMB13.0 million and RMB961,000 respectively. The Directors believe that income derived from the sale of related computer products does not and will not constitute a major source of net profit due to its relative lower profit margin.

BUSINESS OF THE GROUP

The turnover breakdown of each product/system solution of the Group during the Track Record Period was as follows:

	Year ended 31 December		
	2001	2002	2003
	<i>RMB'000</i>	<i>RMB'000</i>	<i>RMB'000</i>
Turnover			
<i>Traffic monitoring and control sector:</i>			
Red Light Overshoot Automatic Recording System	4,131	6,456	18,920
Highway Vehicle Intelligent Monitoring and Recording System	7,148	23,357	15,154
City Traffic Command Centre System	972	3,707	9,017
Mobile Vehicles Inspection System	–	–	229
Police Inspection and Reporting Post Information Management System	–	–	2,992
<i>Customs logistics monitoring sector:</i>			
Customs International Wharf Project	4,672	11,183	6,269
Customs Export Processing Zone Project	8,952	5,063	8,917
	25,875	49,766	61,498
Less: Sales tax and surcharge	(189)	(636)	(623)
	25,686	49,130	60,875
Sales of related computer products	7,029	13,045	961
	32,715	62,175	61,836

SALES, MARKETING AND SERVICES

Sales and marketing

The Group only provides its video security system solutions in the PRC. As at the Latest Practicable Date, the Group had a sales and marketing team of 36 staff, 4 of whom are sales contact persons stationed in Ningbo in Zhejiang province, Jinan in Shandong province, Xiamen in Fujian province and Beijing respectively. These sales contact persons are responsible for providing timely after-sales and consultancy services to major customers of the Group in these cities.

As a major developer and provider of video security system solutions targeting on the PRC government authorities, the Group's customers includes various traffic monitoring and control departments, public security bureau under various municipalities, and customs authorities at various levels in the PRC. The orders from the aforesaid organisations are usually short to medium term projects, which are individual and non-recurring in nature. These projects mostly involve system design, implementation and provision of system solutions and the

BUSINESS OF THE GROUP

Group principally obtains such orders by placing competitive bids to the relevant government authorities. Generally, the Company bids for projects in response to tender invitations by relevant government authorities. For each of the three years ended 31 December 2003, the Company tendered for 9, 25 and 20 projects respectively, out of which it successfully bid for 5, 12 and 10 projects respectively.

The Group participates in exhibitions and seminars to promote its video security system solutions in the PRC. The Group has participated in the following exhibitions/seminars:

Date	Name of the exhibition/seminar
October 1999	The Sixth Multi-national City Traffic Exhibition (第六屆多國城市交通展覽會)
November 2000	Shanghai International Intelligence Traffic and Management Technology Seminar (上海國際智能交通及管理技術研討會)
June 2001	The Second North East International Intelligence Traffic Seminar (第二屆東北國際智能交通研討會)

The Group has also marketed its brand name “神保” by advertising in newspapers and magazines.

Technical services

The Group provides implementation services to its customers, by assigning its technical personnel to the customers for on-site installation, provides technical training to the customer's staff and answers their questions in respect of site use of the Group's products and system solutions. In addition, instruction manuals are also provided to its customers, these technical personnel will also provide technical support and are responsible for the collection of feedback from the customer to improve the quality of the Group's products and facilitate the innovation of future new products.

CUSTOMERS

The customers of the Group are mainly government authorities, including the Ministry of Public Security of the PRC (中華人民共和國公安部) and customs authorities in various provinces in the PRC. For each of the three years ended 31 December 2003, the sales to government or government agencies amounted to approximately 61.5%, 79.4% and 79.5% respectively of the total turnover of the Group. In general, each government department will determine the number and scale of the bids to offer by reference to its annual budget. The Group would bid for projects in response to tender invitations by relevant government authorities. The tender results would be communicated in writing to the tender participants. The Group derives most of its revenue from government projects in which government authorities would generally engage the Group to provide system solutions and services in respect of any of their projects. Accordingly, most of the Group's revenues are non-recurring and not long-term in nature and there is no guarantee that PRC government authorities will continue to engage the Group to provide system solutions and services for each project in the future.

BUSINESS OF THE GROUP

The map below depicts the distribution of Group's customers that are currently using the Group's video security system solutions.



For each of the three years ended 31 December 2003, the total sales to the five largest customers of the Group amounted to approximately RMB11.1 million, RMB33.2 million and RMB27.5 million respectively, representing approximately 34.0%, 53.4% and 44.5% of the total sales of the Group. For each of the three years ended 31 December 2003, sales to the largest customer accounted for approximately 9.7%, 23.7% and 14.7% of the total sales of the Group.

Save as disclosed herein, during the Track Record Period, none of the Directors, Supervisors, their respective associates or any shareholders holding 5% or more of the Company's registered capital had any interest in any of its customers.

During the Track Record Period, the Company sold its system solutions to over 50 customers. The following table shows the number of customers during the Track Record Period:

	Year ended 31 December		
	2001	2002	2003
Number of customers	58	51 (Note)	51

Note: 22 of the customers in 2002 are recurrent customers during the Track Record Period who had also engaged the Group in 2003. Accordingly, out of the 51 customers in 2003, 29 were new customers.

BUSINESS OF THE GROUP

The Group's sales are denominated in RMB. All sales transactions are settled by cheques/bank drafts or telegraphic transfer and are agreed to be made by instalments. For each of the three years ended 31 December 2003, approximately 5%, 23% and 6% of the payment of sales transactions of the Group were settled by cheques/bank drafts respectively and the remaining of approximately 95%, 77% and 94% of the sales transactions was settled by telegraphic transfer respectively. The Group issues bills to its customers on a project by project basis and in respect of a particular project, bills would generally be issued at different stages of completion as stipulated in the relevant contract. The Group has not entered into any long term contracts with any of its customers.

For the provision of video security system solutions, the Group normally determines the credit period to be granted to a particular customer according to the business size of that customer, the length of established business relationship, the contract amount and the customer's past payment record. The Group adhered strictly to its credit policy during the Track Record Period. The bills are generally issued by instalments at different stages: (i) upon signing of contract; (ii) after preliminary acceptance of project; and (iii) after final acceptance of project by the customers. Normally, customers will settle the full sales proceeds within 90 days after issue of the relevant bills while some customers with sizeable businesses may be allowed 180 days after issue of bills to effect full settlement. The customers with prolonged credit terms include the Traffic Police Headquarters of the Public Security Bureau of Shandong Province (山東省公安廳交通警察總隊) and the Procurement and Supply Centre of the General Administration of China Customs (海關總署物資裝備供應中心), which are both PRC government authorities. They are the Group's major customers and the Directors believe that their default risks are lower than those of private companies. For sales of related computer products, the orders are generally in small quantity and amounts and the Group normally grants a credit period of 90 days to its customers.

The Group has based on the aging of the outstanding trade receivable and made provisions for doubtful debts according to the following schedule:

Aging of trade receivable	Provisions in percentage
Not exceeding 1 year	Nil
More than 1 year but less than 2 years	50%
More than 2 years	100%

In addition, the Group also makes provision for debts with doubtful collectibility with regards to the payment history of the customers.

BUSINESS OF THE GROUP

The Group assigns one staff member from each of the traffic monitoring and control department and the customs logistics monitoring department to keep track of the aging and settlement of receivables. They report the aging status to the senior management of the Group on a monthly basis. The aging analysis of trade receivables during the Track Record Period is as follows:

	2001	2002	2003
	<i>RMB'000</i>	<i>RMB'000</i>	<i>RMB'000</i>
0 to 90 days	8,516	29,442	29,421
91 to 180 days	1,396	470	—
181 to 365 days	2,265	415	—
1 to 2 years	2,920	467	—
Over 2 years	905	—	—
	<u>16,002</u>	<u>30,794</u>	<u>29,421</u>

Note: The above aging analysis refers to the days commencing from the date of invoice.

For the purpose of collecting outstanding payments from the customers, the Group sends to the customers standardised Project Payment Forms (工程付款申請表) prepared by the Construction Department of Jiangsu Province (江蘇省建設廳). At the same time, project managers of the Group would also visit the customers to remind them of the outstanding payments due to the Group.

The Group may consider taking legal action to collect the outstanding payments from customers after the Directors have critically reviewed the repayment status of each debtor taking into account their repayment history, the follow up work to be performed by the Group (debtors may hold up their final payment when the Group is yet to complete their follow up orders) and the financial position of the debtor. After such review, the Directors will decide the appropriate action to be taken and/or provisions will be specifically made for those debts which are assessed to be doubtful.

The Group adhered strictly to its provision policy during the Track Record Period. The Group made allowance for bad and doubtful debts of RMB503,000 in 2002. No allowance for bad and doubtful debts was made for the year ended 31 December 2003. The following table illustrates the subsequent settlement of the Group's trade receivable as at 30 April 2004:

	<i>RMB'000</i>
Trade receivable as at 31 December 2003	29,421
Less: subsequent settlement up to 30 April 2004	<u>(11,416)</u>
Remaining balance	<u>18,005</u>

BUSINESS OF THE GROUP

SEASONALITY

The Group normally experiences higher sales during the second half of the year because most of the government projects are offered for tender from October to December each year. Accordingly, majority of trade receivables as at year ends would fall within the "0 to 90 days" category. The percentage changes of different classes of trade receivables from 2002 to 2003 demonstrate that the Group had exercised tight control over debt collection to minimise the risk of bad debt.

Given such seasonality that the Group experiences higher sales during the second half of the year and the Group's normal practice in granting a credit period of 90 to 180 days after the issue of bills, the customers from October to December each year may not settle the receivables in full until May or June in the following year. Accordingly, the Group may experience tight working capital and a relatively longer debtors turnover during the first half of the year.

SUPPLIERS

The Group's main procurement items include cameras, computers, wires and cables, graphic cards, television sets, and hardware.

For each of the three years ended 31 December 2003, the amounts of total purchases from the five largest suppliers were approximately RMB5.3 million, RMB9.5 million and RMB10.9 million respectively, representing approximately 24.3%, 37.1% and 36.7% of the total purchase amount for the respective years. The largest supplier accounted for approximately 7.9%, 12.5% and 12.2% of the total purchase amount for the respective years.

Save as disclosed herein, for each of the three years ended 31 December 2003, none of the Director(s), Supervisors, their respective associates or any shareholders holding 5% or more of the Company's registered capital had any interest in any of the five largest suppliers of the Company.

At present, purchases by the Group are denominated in RMB. Credit terms ranging from 0 to 90 days are granted by suppliers depending on the volume of purchases. All purchases are settled by cheques/bank drafts or telegraphic transfer. For each of the three years ended 31 December 2003, approximately 64.3%, 64.0% and 56.7% of the payment of purchases of the Company were settled by cheques/bank drafts respectively and the remaining of approximately 35.7%, 36.0% and 43.3% of the purchases were settled by telegraphic transfer respectively. Generally, the Group enters into one-year purchase contracts with the suppliers. All purchases are made through contracts based on customer demand. As the raw materials purchased by the Group are commonly available in the market and are provided by various different suppliers in the PRC, the Group can purchase raw materials from alternative sources if its major suppliers cease to provide raw materials.

INVENTORY CONTROL

The Group's inventories comprise raw materials and equipment stocked for resale. As at 31 December 2001, 31 December 2002 and 31 December 2003, the closing balance of the Group's inventories amounted to approximately RMB13.3 million, RMB2.7 million and RMB1.6 million respectively, which represented approximately 32.0%, 5.0% and 2.1% of the Group's net assets respectively. The Directors believe that an effective inventory control policy is important to manage the Group's working capital.

BUSINESS OF THE GROUP

Inventory is stock-counted monthly and the stock take is usually jointly conducted by personnel from the accounting department and the stock master. An inventory report is prepared and any discrepancy will be investigated.

The nature of the Group's business requires it to keep a minimal inventory level. The Group's inventory consists of low level of raw materials and equipment, therefore the Group did not make any stock provision during the Track Record Period and had not adopted any active stock provision policy. The inventory turnover days of the Group were 149 days, 16 days and 9 days for each of the three years ended 31 December 2003 respectively.

RESEARCH AND DEVELOPMENT

The Group places strong emphasis on the R&D of video security system solutions for the traffic monitor and control sector and the customs logistics monitoring sector in order to keep up with the development of the latest needs of its clients in the PRC. The Directors consider that a strong R&D capability is important to ensure the Group's success and its ability to develop video security system solutions to meet the requirements of government authorities or private enterprises for the traffic monitoring and control sector and the customs logistics monitoring sector, and also enables the Group to have the capability to continue to upgrade its existing system solutions in response to the changes in technological development.

The R&D staff of the Group work closely with the sales and marketing staff of the Group. Feedbacks from sales and marketing staff help guide the Group's development of its system solutions to meet the requirements of different customers. To maintain the quality and market awareness of the R&D team, the Group provides ongoing technical training and seminars to its R&D staff. Some members also attend and participate in exhibitions and external seminars to keep abreast of the latest technological developments and maintain regular contact and discussion with the PRC government authorities and private enterprises to acknowledge the market needs. The following list sets out the major video security system solutions that the R&D team had been involved in during the Track Record Period:

Traffic monitoring and control sector

- Mobile Vehicles Inspection Police System (移動式車輛緝查系統)
- EPV2000 ePolice (EPV2000電子警察)
- Police Inspection and Reporting Post Information Management System (警察查報站信息管理系統)
- VR4000 Series Highway Vehicles Intelligent Monitoring and Recording System (VR4000系列公路車輛監測與記錄系統)

Customs logistics monitoring sector

- Export Processing Zone Checkpoint Automatic Inspection System (出口加工區卡口自動查驗系統)
- Distributive Intelligence Customs Logistics Monitoring System (分佈式智能海關物流監控系統)

To cope with the Group's R&D initiatives and strategies, the Group intends to strengthen and concentrate its efforts on developing and upgrading its video security system solutions to enhance the quality and reliability of its system solutions. As set out in the paragraph headed "Implementation plan – Costs of implementation of business objectives" under the section headed "Statement of business objectives" in this prospectus, the Group intends to spend approximately HK\$2.3 million, HK\$4.5 million and HK\$4.6 million of

BUSINESS OF THE GROUP

the net proceeds from the Placing of the New H Shares in R&D and upgrading of the system solutions for the years ending 31 December 2004, 31 December 2005 and 31 December 2006 respectively. It is the intention of the Group to increase its R&D spending after the listing of the H Shares on GEM to capitalise on the potential and prospects of the video security market and the expected demand for their system solutions.

Expenditures on R&D are recognised as expenses in the period in which they are incurred. The Group's R&D expenses were approximately RMB877,000, RMB1.7 million and RMB2.2 million respectively for each of the three years ended 31 December 2003 and the Group intends to increase such expenses significantly during the Forward Looking Period. Accordingly, the Directors expect that the Group will implement a relatively larger scale of R&D activities after the listing of the H Shares on GEM. The Directors consider that such significant increase in R&D spending is necessary to pursue the Group's business strategies and objectives and to strengthen its core technologies in order to develop and enhance its video security system solutions and maintain its leading position in the market.

The following list sets out the major R&D initiatives that the Group intends to carry out during the Forward Looking Period:

- Expansion and upgrade of the functions of ePolice to meet the changing demands and requirements of governmental authorities for the traffic monitoring and control sector in the PRC
- Intensification of certain sub-systems for the Group's system solutions in the customs logistics monitoring sector to strengthen the functionality and technicality of the system solutions for this sector
- Enhancement of the Group's visual identification and RFID technologies in their applications for the video security system solutions in both traffic monitoring and control sector and customs logistics sector

The Group considers that ePolice will continue to be in demand by the PRC government authorities in accordance with their initiatives in the informationalisation of traffic sector in the PRC by extensively utilising and implementing information service and technology in their traffic monitoring network system. The Group also intends to focus on the R&D of certain sub-systems for its customs logistics monitoring system. Such sub-systems will strengthen the functionality and technicality of the Group's customs logistics monitoring system. The Directors believe that such initiative is important to meet the future needs of most local custom bureaus which will enable the expedition of their cargo monitoring and verification processes. Depending on the necessity and requirements of the R&D initiatives, the Group may also acquire or purchase additional R&D equipment and/or facilities. As at the Latest Practicable Date, the Group had no commitment as to purchasing any equipment and/or facilities for its R&D activities.

Details of the video security system solutions that the Group intends to develop and upgrade for the traffic monitoring and control sector and the customs logistics monitoring sector and the expected time frame are set out in the paragraph headed "Implementation plan – Product development and upgrade" under the section headed "Statement of business objectives" in this prospectus. The Group intends to target PRC government authorities (for the traffic monitoring and control sector) and general local custom bureaus (for the customs logistics monitoring sector) in major provinces in the PRC as the major customers of its video security system solutions under R&D.

BUSINESS OF THE GROUP

To accompany such strengthened R&D efforts and initiatives, the Group also intends to expand its R&D team progressively. As at the Latest Practicable Date, the Group had a R&D team of 35 professionals. The Directors intend to expand the Group's R&D team with 85 members by the end of 2006. Details of the expansion plans of R&D team are set out in the paragraph headed "Implementation plan – Allocation of human resources" under the section headed "Statement of business objectives" in this prospectus. The Group intends to recruit approximately 15 to 20 new members per year to expand its R&D team during the Forward Looking Period to satisfy its strengthened R&D efforts and initiatives. Most of the members of the current R&D team have received tertiary education and the Directors intend to recruit additional members with bachelor or master degrees in computer science or related disciplines in video security or technology who are also experienced in software programming and system analysis. The Directors anticipate that such expansion in R&D team will incur an overhead increment of approximately RMB2.0 million every year during the Forward Looking Period and the Group will provide on-the-job training and seminars to these R&D members at the training base located at the Technology Park.

COMMERCIALISATION OF SYSTEM SOLUTIONS

After the Group's R&D team successfully develops new video security system solutions or upgrades its existing system solutions, the Group will undertake commercialisation processes to test the functionality and technicality of the system solutions and see whether these system solutions satisfy the requirements of the Group's customers, in particular, the government authorities in the PRC. The commercialisation processes of the video security system solutions will be mainly performed by the technology centre and sales and marketing centre of the Group. These two centres together will assess the functionality and technicality of the system solutions by running the system solutions at different settings and performing series of debugging tests to confirm their reliability and applicability before the Group releases such system solutions to its customers.

The Directors consider that commercialisation of system solutions is important to ensure that the Group's system solutions meet and satisfy the requirements of its customers and maximise the economic values of its system solutions from the users' perspective. In particular, commercialisation also enables the Group to assess the level of acceptance in the market before it decides to place extensive efforts and resources in production and sales and marketing to launch the system solutions.

The commercialisation processes of the Group's system solutions will be mainly supervised by Mr. Chang Yong (常勇) and Mr. Fu Yu Qing (富煜清). They will determine the priority of which system solutions to be commercialised in light of prevailing trends in both traffic monitoring and control sector and customs logistics monitoring sector. Mr. Chang obtained a master degree in computer application studies and worked for the computer centre of the Nanjing Bureau of Finance (南京市財政局). Mr. Fu was an instructor of the Faculty of Wireless Communication and general engineer of the research institute of Southeast University (東南大學). Details of the qualifications and background of Mr. Chang and Mr. Fu are set out under the section headed "Directors, supervisors, senior management and staff" in this prospectus.

To match with the Group's intention to strengthen its efforts in R&D initiatives and strategies during the Forward Looking Period, the Group will also focus its efforts in this commercialisation process. The Directors consider that the Group's current commercialisation capabilities are insufficient to cope with its enlarged business and operating scale and strengthened R&D capabilities after the listing of the H Shares on GEM. Accordingly, the Directors intend to spend approximately HK\$9.0 million of the net proceeds from the Placing of the New H Shares during the Forward Looking Period to purchase additional equipment and/or facilities in enhancing the Group's commercialisation capabilities and efficiency. Details of the expected time frame of such

BUSINESS OF THE GROUP

spending are set out in the paragraph headed “Implementation plan – Cost of implementation of business objectives” under the section headed “Statement of business objectives” in this prospectus. The accounting policy for such expenditures on plant and equipment follows Statement of Standard Accounting Practice 17 “Property, Plant and Equipment” issued by the Hong Kong Society of Accountants and expenditures spent on the acquisition of equipment and facilities for the commercialisation of system solutions are capitalised at cost and stated at cost less depreciation and any identified impairment loss. As at the Latest Practicable Date, the Group had no commitment as to purchasing any equipment and/or facilities for commercialisation of system solutions. As commercialisation activities will be mainly performed by the technology centre and sales and marketing centre of the Group, the Directors also intend to expand the size of the relevant team during the Forward Looking Period. Expected time frame and number of personnels to recruit are set out in the paragraph headed “Implementation plan – Allocation of human resources” under the section headed “Statement of business objectives” in this prospectus.

After the Group successfully developed and commercialised new system solutions, it will consider formally launching and providing the system solutions to its target customers. Such launching activities will be responsible by certain departments of the Group including the project services centre and sales and marketing centre. Responsible personnels of the two centres of the Group will liaise with each other and arrive at the appropriate marketing and promotion strategies and determine the number of sales and marketing personnels that the Group will allocate for promoting the system solutions. Accordingly, the Group’s sales and marketing centre will be involved in both commercialisation and launching stages of new system solutions. The Directors consider that such arrangement enables the responsible personnels of the sales and marketing centre to (i) obtain feedback from the Group’s target customers at an early stage which is useful for the commercialisation process; and (ii) have sufficient timing and planning in formulating the marketing and promotion strategies before the new system solutions are formally released to the market after commercialisation.

COMPETITION



The Group is principally engaged in the provision and operation of video security system solutions for use in the traffic control and monitoring sector and the customs logistics monitoring sector. In the PRC, there exists other companies that are engaged in the provision of video security system solutions for usage in other sectors, such as warehouse security, irrigation system management and cargo logistics management.

The Directors believe that the principal strengths of the Group lie in its video security technology, its experience in the traffic monitoring and control sector and the customs logistics monitoring sector, its management and R&D team and the Company’s shareholder background. However, the Directors consider that the competition in the provision and operation of video security system solutions business is generally intense, particularly in the provision of system solutions similar to ePolice and the Highway Checkpoint Inspection System as there are a number of companies in the PRC that are engaged in the provision of system solutions. The Directors also consider that entry barrier to the business in which the Group operates is relatively low in the PRC. To the best of the Directors’ knowledge, most of these competitors, unlike the Group which operates at a nationwide level, only serve certain provincial governments.

To the best of the Directors’ knowledge, none of themselves, the Initial Management Shareholders and Substantial Shareholders has business or interest that compete or may compete with the business of the Group or any other conflict of interest with the Group.

INTELLECTUAL PROPERTY RIGHTS

The Group adopts the trademarks “” and “神保” to market its business. Such trademarks are owned by Sample Group and are registered in its name in the PRC. The Company and Sample Group entered into the Licence Agreement pursuant to which Sample Group agreed to grant a licence to the Company for the use of, inter alia, the trademarks “” and “神保” at nil consideration with effect from 1 January 2001. Pursuant to the Supplemental Agreement, Sample Group irrevocably agreed to grant a licence to the Company for, inter alia, (i) the use of the trademark “”; and (ii) the exclusive use of the trademark “神保” in connection with the services within the scope of approved services in the trademark registration certificate nos. 1223813 and 1223880 (i.e. class 42) at nil consideration. The licence period for (i) commenced on 1 January 2001 until 31 July 2008 whilst the licence period for (ii) commenced on 1 January 2001 until the earlier of (a) 31 July 2008; and (b) the date when the necessary procedures for the transfer of the trademark have been completed pursuant to the exercise of the Transfer Option under the Option Agreement. Under the Supplemental Agreement, Sample Group retains the right to use the trademark “” in connection with services included in class 42 and the Company was granted a pre-emptive right to acquire the trademarks “” and “神保” should Sample Group intend to transfer the same to third parties under the same terms and conditions after the expiry of the Supplemental Agreement.

The trademarks “” and “神保” are both registered in the name of Sample Group for a period from 14 November 1998 to 13 November 2008. Sample Group principally applied the trademark “” to its promotional brochures and letterheads and it did not use the trademark “神保” in any areas or products as at the Latest Practicable Date.

The Company and Sample Group entered into the Option Agreement pursuant to which the Transfer Option was granted to the Company by Sample Group exercisable from the date of signing of the Option Agreement to 31 July 2008 (“Option Period”). During the Option Period, the Company may, by written notice, request Sample Group to transfer the trademark “神保” to the Company at nil consideration. According to the Articles of Association, the non-exercise of the Transfer Option will not be subject to approval from the independent Shareholders and/or the independent non-executive Directors. It was further agreed that save for the tax required to be paid for the transfer of the trademark “神保”, which shall be paid by the parties in accordance with PRC laws, rules and regulations, the Company is not required to bear any costs in relation to the execution of the Option Agreement, the exercise of the option thereunder and the transfer of the trademark “神保”. It is the intention of the Directors to exercise the Transfer Option upon listing of the H Shares on GEM.

In addition, as at the Latest Practicable Date, the Group was the registrant of the domain name “sampletech.cn” and had registered nine copyrights in the PRC. The Group has relied on the confidentiality or contractual agreements with the Directors and its R&D staff, as well as the relevant PRC laws and Hong Kong laws, to protect and limit access to and distribution of the intellectual property rights that the Group has developed or acquired.

In accordance with the Regulations for the Protection of Computer Software (計算機軟件保護條例) issued by the State Council, which were promulgated on 20 December 2001 and implemented on 1 January 2002, the protection period for software copyright of a legal person or organisation should be 50 years, concluding on 31 December of the 50th year after the software's initial release.

The PRC legal advisers to the Company advise that pursuant to the Regulations for Publication Rights in the PRC (中華人民共和國著作權法) and the Regulations for the Protection of Computer Software (計算機軟件保護條例), registration of copyright is not legally mandatory. Copyright owners may select not to make copyright registration and non-registration does not constitute abandonment or deletion of such copyright.

BUSINESS OF THE GROUP

Certificates issued by the software registration authorities are preliminary proof of registration. Under these software protection regulations, software copyright holders enjoy the right of publication, right of authorship, right of amendment, right of copying, right of issue, right of renting, right of network transmission, right of translation, and any other rights which the software copyright holders shall be eligible to enjoy. Upon completion of the registration procedures, the legal right of the copyright owner on the registered software products shall be properly protected.

As at the Latest Practicable Date, the relevant member of the Group was the registered owner of the following copyrights:

Name of copyright	Registered owner	Registration number	Commencement date
Customs Checkpoint Automatic Inspection System V1.0 (海關關口自動查驗系統V1.0)	The Company	2001SR1342	1 January 2000
Highway Vehicle Monitoring & Recording System V1.0 (公路車輛監測與記錄系統V1.0)	The Company	2001SR1343	1 August 1998
Golden Dragon Highway Vehicle Monitoring and Data Management Software V1.0 (金龍公路車輛監測數據管理軟件V1.0)	Golden Dragon Software	2002SR4153	10 March 2002
Golden Dragon Customs Checkpoint Monitoring Software V1.0 (金龍海關關口監控軟件V1.0)	Golden Dragon Software	2002SR4154	10 March 2002
Golden Dragon Multi-media Display Software V1.0 (金龍多媒體展示軟件V1.0)	Golden Dragon Software	2003SR7615	10 March 2002
Golden Dragon Prosecution Business Management Software V1.0 (金龍起訴業務管理軟件V1.0)	Golden Dragon Software	2003SR8603	10 March 2002
Golden Dragon Justice Monitoring Management Software V1.0 (金龍司法監控管理軟件V1.0)	Golden Dragon Software	2003SR8604	10 April 2002
Golden Dragon Highway Vehicles Rule-violation Monitoring Software V1.0 (金龍公路車輛違章監測軟件V1.0)	Golden Dragon Software	2003SR8605	10 March 2002
Golden Dragon Rule-violation Vehicle Penalty Management Monitoring Software V1.0 (金龍違章車輛處罰管理監測軟件V1.0)	Golden Dragon Software	2003SR8606	10 April 2002

Other software products or system solutions of the Group are basically developed on the basis of the existing series of software products according to different requirements of different aspects.

BUSINESS OF THE GROUP

As at the Latest Practicable Date, the Company was the registered owner of the following patents:

Name of patent	Registered owner	Registration number	Commencement date
Industrial Outdoor Cabling Rack (工業室外機櫃)	The Company	ZL 03 3 16579.3	10 December 2003
Multi-dimensional Image Recorder Flange Plate (多自由度攝像機安裝法蘭盤)	The Company	ZL 03 2 20057.9	14 April 2004

As at the Latest Practicable Date, the Company had applied for registration of the following patents:

Name of patent	Name of applicant	Application number	Application date
Industrial Outdoor Cabling Rack with Temperature Control (工業室外溫控機櫃)	The Company	03222018.9	22 May 2003
Multi-flashing Lights (複合式閃光照明燈)	The Company	03222019.7	22 May 2003
Taxi Image Alarming and Recording Metre (出租車圖像報警記錄儀)	The Company	03222020.0	22 May 2003
All-in-one Intelligent Image Capturing Device (一體化智能圖像採集器)	The Company	03222021.9	22 May 2003
Taxi Passenger Inspection and Detection Device (出租車載客檢測器)	The Company	03278210.1	1 September 2003
Distributed Infrared Light Emitting Diode for Taxi Image Alarming and Recording Metre (出租車圖像報警記錄儀拍攝用 分佈式紅外照明裝置)	The Company	03278383.3	8 September 2003
3 Dimensional U-shape Image Recorder Flange Plate (三自由度U型攝像機安裝法蘭盤)	The Company	03278384.1	8 September 2003
Red Light Overshooting Law Violation Photographs Automatic Selection Method (闖紅燈違章照片自動篩選方法)	The Company	200310106049.7	13 October 2003
Complete Image Recording Road Traffic Monitoring and Detection Equipment (記錄圖像完整的道路車輛監測裝置)	The Company	200320123321.8	18 December 2003
Embedded Supplemental Image Recording Road Traffic Inspection and Detection Equipment (採用補償圖像的嵌入式道路 車輛檢測記錄裝置)	The Company	200320123323.7	18 December 2003

Further details in relation to the Group's intellectual property rights are set out in the paragraph headed "Intellectual property rights" in Appendix VII to this prospectus.

BUSINESS OF THE GROUP

AWARDS AND HONOURS

The Group is strong in developing its video security technologies and has won a number of awards of excellence and technological progress at provincial and municipal levels. The Directors consider that such awards and honours obtained by the Group signified its strengths in the development of its video security system solutions applying in (i) the traffic monitoring and control sector; and (ii) the customs logistics monitoring sector. Those awards and honours also represent the recognised position of the Group in the industry and market awareness of its video security system solutions. The awards granted by institutions also serve as an indicator of the quality of the video security system solutions developed by the Group. The key awards and honours received by the Group are set out as follows:

Date/Year of grant	Awards and honours	Awarding body
March 1999	Nanjing Excellent Private Technology Enterprise (南京市優秀民營科技企業), a recognition by the municipal government as to the Company's reputation in the industry, contributions to the domestic economy and contribution to the development of high and new technologies	Nanjing Municipal People's Government (南京市人民政府)
November 1999	Wide Area Digital Supervision Alarm System (廣域數字化監控警報系統) was awarded State Key New Products (國家重點新產品)	The Ministry of Science and Technology of the PRC, the State Administration of Taxation, the State Quality and Technology Supervision Bureau, the Ministry of Foreign Trade and Economic Co-operation of the PRC and the State Environment Protection Administration (中華人民共和國科學技術部，國家稅務總局，國家質量技術監督局，中華人民共和國對外貿易經濟合作部及國家環境保護總局)
December 1999	Wide Area Digital Supervision Alarm System (廣域數字化監控警報系統) was awarded Nanjing Municipal Technology Progress Award (南京市科學技術進步獎)	Nanjing Municipal People's Government (南京市人民政府)
2000	Year 2000 Meritorious Unit in the Construction of New Nanjing (2000年度建設新南京有功單位), a recognition by the municipal government as to the Company's contribution to Nanjing	Nanjing Municipal People's Government (南京市人民政府)

BUSINESS OF THE GROUP

Date/Year of grant	Awards and honours	Awarding body
April 2000 (Note)	Highway Vehicle Monitoring and Recording System (公路車輛監測與記錄系統) was awarded State Key New Products (國家重點新產品)	The Ministry of Science and Technology of the PRC, the State Administration of Taxation, the State Quality and Technology Supervision Bureau, The Ministry of Foreign Trade and Economic Co-operation of the PRC and the State Environment Protection Administration (中華人民共和國科學技術部，國家稅務總局，國家質量技術監督局，中華人民共和國對外貿易經濟合作部及國家環境保護總局)
April 2000	Highway Vehicle Monitoring and Recording System (公路車輛監測與記錄系統) was awarded State Torch Program Project (國家級火炬計劃項目)	Torch Hi-Tech Industry Development Centre of the Ministry of Science and Technology (科學技術部火炬高技術產業開發中心)
December 2000 (Note)	Highway Vehicle Monitoring and Recording System (公路車輛監測與記錄系統) was awarded Nanjing Municipal Year 2000 Science and Technology Advancement Third Prize (南京市2000年度科學技術進步三等獎), a recognition of the system's level of technology by the municipal government	Nanjing Municipal People's Government (南京市人民政府)
August 2001	Key High and New Technology Enterprise Certificate (重點高新技術企業證書), a recognition that the Group is supported by the PRC government's policy in promoting high and new technologies	Torch High Technology Industry Development Centre of the Ministry of Science and Technology (科學技術部火炬高技術產業開發中心)
2001 and 2003	Nanjing Municipal Private Advance Technology Enterprises (南京市民營科技先進企業), a recognition by the municipal government as to the Group's contribution to the domestic economy and development of high and new technologies, and the amount of contributed profit tax	Nanjing Municipal People's Government (南京市人民政府)

Note: The award was granted to Sample Industry, the entity which supplied the system at the time of receiving the award. Since February 2000, the system has been supplied by the Company.

BUSINESS OF THE GROUP

Date/Year of grant	Awards and honours	Awarding body
August 2002	Highway Checkpoint System (公路卡口系統) and ePolice were certified as in conformity with the ISO9001:2000 standard	Jiangsu Quality Guarantee Centre (江蘇質量保證中心)
September 2002	Distributive Intelligent Customs Logistics Monitoring System (分佈式智能海關物流監控系統) was recognised as Key Technologies R&D Programme Project (國家科技攻關計劃項目)	The Ministry of Science and Technology of the PRC (中華人民共和國科學技術部)
December 2002	High and New Technology Enterprise Recognition Certificate (高新技術企業認定證書), a recognition that the Group is supported by the PRC government's policy in promoting high and new technologies	Jiangsu Science and Technology Department (江蘇省科學技術廳)
March 2003	Nanjing Municipal Year 2000–2002 Civilisation Unit (南京市2000-2002年度文明單位), a recognition by the municipal government as to the Company's contribution to Nanjing	Nanjing Municipal People's Government (南京市人民政府)
December 2003	Advance National Information Industry System Organisation (全國信息產業系統先進集體), an honour as to the Group's contribution to the development of information industry in the PRC	The Ministry of Personnel of the PRC and the Ministry of Information Industry of the PRC (中華人民共和國人事部及中華人民共和國信息產業部)

BUSINESS OF THE GROUP

IMPACT OF THE PRC'S ACCESSION TO THE WTO

After the PRC gains accession to the WTO, the video security market may be subject to competition by foreign companies. The Directors, however, believe that due to concern over State security and the relatively superior understanding of the bidding process for government projects by PRC developers, the PRC government or some of the government related entities would prefer assigning security projects to domestic companies and, accordingly, competition between the Group and its domestic rivals may be greater than that between the Group and its foreign competitors.

Although foreign competitors generally possess strong financial background and advance technology know-how, they are still lack of specific market knowledge. Besides, the Directors believe that the PRC's accession to the WTO provides opportunities for the Company to co-operate with international corporations. Accordingly, this may also represent an opportunity for the Group to expand its business.

STRATEGIC ALLIANCE

The Company has formed strategic alliances with the following partners:

Strategic partner	Nature	Agreement date
High Technology Centre of Southeast University (the "Hi-Tech Centre") (東南大學高科技中心)	Technology and marketing co-operation	20 October 2003 for a term of 2 years
Nanjing University of Science and Technology ("NUST") (南京理工大學)	Technology co-operation	5 August 2003

Such co-operations with the Hi-Tech Centre and NUST are described as follows:

Hi-Tech Centre

Nanjing Southeast University is one of the key national universities under the Ministry of Education of the PRC (中國教育部) and is also one of the universities accredited by the State Council to determine and approve the qualifications of professor, associate professor and doctoral supervisor. The Company and the Hi-Tech Centre entered into a co-operative agreement for a term of two years starting from 20 October 2003 to 19 October 2005. Under this agreement, the Company agreed to allocate human resources and capital in promoting products or research findings of the Hi-Tech Centre. The Hi-Tech Centre, in return, is obliged to ensure the progress of projects undertaken by the Company by assigning sufficient human resources and facilities. In addition, both parties have agreed to jointly participate in operational activities, such as case discussion and placing bids, when undertaking relatively large-scale projects.

BUSINESS OF THE GROUP

NUST

NUST was established in 1953 and is now one of the key national universities under the Commission of Science Technology and Industry for National Defense (科技及國防工業委員會). On 5 August 2003, the Company and NUST entered into an agreement of application on establishing the Transportation Safety and Traffic Securities Intelligent System Engineering Technical Centre of Jiangsu Province (江蘇省運輸安全與交通治安智能系統技術中心) (the "Technology Centre"). The objective of establishing the Technology Centre is to encourage R&D on ITS products/system solutions, which will be launched in the open market for sale. Pursuant to the agreement, the Company is responsible for the operating costs of the Technology Centre after deducting the government's investments and NUST is responsible for the R&D costs in exploring the application of visual security technology in traffic monitoring and control sector. Pursuant to the feasibility study report dated 26 July 2003, the Company and NUST intend to invest approximately RMB13.4 million in aggregate into the Technology Centre for the first three years.

The Directors believe that, through the co-operative relationship between the Group and each of the Hi-Tech Centre and NUST, the Group has the ability to meet the market development trend by improving its research and development capabilities, developing innovative video security products/system solutions, and improving its existing products/system solutions on a continuous basis. As at the Latest Practicable Date, the Group had not contributed any funding for the co-operation between the Group and any of its partners.

PRINCIPAL STRENGTHS OF THE GROUP

The mission of the Group is to be a market leader in the provision and operation of video security system solutions for the traffic monitoring and control sector and the customs logistics monitoring sector in the PRC. The Group, through such business orientation and backed by the prospects of the video security market in the PRC, is committed to excel in the industry to provide quality video security system solutions to the PRC government authorities and private enterprises in the PRC.

The Directors consider the Group's principal strengths are: (i) its video security technology; (ii) its experience in the traffic monitoring and control sector and the customs logistics monitoring sector; (iii) its management and R&D team; and (iv) the Company's shareholder background; which are detailed as follows:

(I) The Group's video security technology

The Group has competitive strengths in developing technologies of real-time image/video capturing, encoding, decoding identification, transmission and web services. This has enabled the Group to respond promptly to market needs.

Traffic monitoring and control sector: the ITS system solution provided by the Group to its clients is a composite artificial intelligence system that integrates TV monitoring, traffic signal control and regulation, wired and wireless communication despatching, capturing and computerised information network of public order checkpoint monitoring as well as public services on the same CTGIS operating platform. As a solution, it assists users to manage traffic through remote monitoring, record keeping and abnormality identification, including the Highway Vehicles Monitoring and Recording System (公路車輛監測與記錄系統), which is recognised by the Ministry of Science and Technology of the PRC (中華人民共和國科學技術部) as a key project under the State Torch Program.

BUSINESS OF THE GROUP

Customs logistics monitoring sector: the system solutions provided by the Group to its clients integrates on-site monitoring, customs inspection and data flow regulation. The Customs Checkpoint Automatic Inspection System (海關關口自動查驗系統) of the Group is recognised by the Ministry of Science and Technology of the PRC (中華人民共和國科學技術部) as a key project under the State Torch Program. In addition, the Group has undertaken the Project of Distributive Intelligence Customs Logistics Monitoring System (分佈式智能海關物流監控系統項目) under the Key Technologies R&D Program (國家科技攻關計劃). The Group won the tender and became the main integration contractor for the core projects of Customs Logistics Monitoring System – the Container Numbers Identification System (集裝箱識別系統) and Electronic Licence Plate Numbers Identification System (電子車牌識別系統) for the General Customs Administration of the PRC (中華人民共和國海關總署).

The Group has won a number of awards of excellence and technological progress awards at provincial and municipal levels. The Company is recognised as a Key High and New Technology Enterprise (重點高新技術企業) by the Ministry of Science and Technology of the PRC (中華人民共和國科學技術部). It is also qualified as a Software Enterprise (軟件企業) by the Jiangsu Information Industry Department (江蘇省信息產業廳), a provincial qualification that entitled the Company to VAT benefit. The Company is the supplier of two State Key New Products (國家重點新產品), namely Wide Area Digital Supervision Alarm System (廣域數字化報警系統) and Highway Vehicle Monitoring and Recording System (公路車輛監測與記錄系統). State Key New Products (國家重點新產品) are products that fulfil the State's industrial requirements and are first researched and developed in the PRC. The Group's Highway Vehicle Monitoring and Recording System (公路車輛監測與記錄系統) was awarded the State Key New Product (國家重點新產品) in the PRC and is qualified under the State Torch Program Project (國家級火炬計劃項目). In addition, the Group is responsible for the operation of the Transportation Safety and Traffic Intelligent System Engineering Technical Centre of Jiangsu Province (江蘇省運輸安全與交通治安智能系統工程技術中心).

(2) The Group's experience in the traffic monitoring and control sector and the customs logistics monitoring sector

Since its establishment, the Group has put much emphasis on the development of system solutions that met the needs of the government authorities and private enterprises in the PRC. In particular, the Group has accumulated experience in the implementation of video security system solutions in the traffic monitoring and control sector and the customs logistics monitoring sector. The Directors believe that these experiences provide the Group with a solid background to implement large scale projects.

Traffic monitoring and control sector: The Group's Red Light Overshoot Automatic Recording System (ePolice) has been adopted by public security departments in 49 different cities in 14 provinces (Anhui, Fujian, Hebei, Henan, Hubei, Jilin, Jiangsu, Jiangxi, Liaoning, Shandong, Shanxi, Sichuan, Yunnan and Zhejiang) and 2 municipalities directly under the central government (Beijing and Chongqing) of the PRC. For the three years ended 31 December 2003, sales revenue of the system solutions for this sector was approximately RMB106.7 million.

Customs logistics monitoring sector: For the year ended 31 December 2003, the Group's Customs Logistics Monitoring System (海關物流監控系統) had been successfully operated by the customs authorities in 19 out of the 38 State-level EPZs. For the three years ended 31 December 2003, sales revenue of the system solutions for this sector was approximately RMB45.9 million.

(3) The Group's management and R&D team

Led by Sha Min (沙敏) and Mr. Fu Yu Qing (富煜清), the chairman and the chief technical officer of the Company respectively, the Group's senior management has a good understanding of the video security market and technological trend, which has put the Group in a leading position in developing and applying video security technologies for its system solutions. The senior management is able to keep abreast of latest market trend to develop and provide video security system solutions that meet the requirements of PRC government authorities and private enterprises in the PRC. As at the Latest Practicable Date, the Group had 172 employees, of whom 35 are R&D personnel. Most of the members of the current R&D team have received tertiary education and are strong in product development and system design and experienced in technical integration.

(4) The Company's shareholder background

Sample Group, a Substantial Shareholder, is a private enterprise equipped with sound and innovative technical know-how and market development capability. Huadong Technology, an A share company listed on the Shenzhen Stock Exchange, is a large key enterprise engaged in the PRC's information technology industry. Nanjing Zhongbei is also an A share listed company in the PRC. The extensive network of these shareholders provide a useful platform for the Group's development.

STATEMENT OF ACTIVE BUSINESS PURSUITS

The statements below set out a summary of active business pursuits of the Group for the three years ended 31 December 2003 and the period from 1 January 2003 to the Latest Practicable Date. The statements should be read in conjunction with the section headed "Industry overview" in this prospectus which sets out the industry background relevant to the business pursuits of the Group.

	For the year ended 31 December 2001	For the year ended 31 December 2002	For the year ended 31 December 2003	For the period from 1 January 2004 to the Latest Practicable Date
--	------------------------------------------------	------------------------------------------------	------------------------------------------------	--------------------------------------------------------------------------------------

Business development

Traffic monitoring and control sector

- | | | | |
|-------------------------------------------------------------------------------------------------------------------------------------------------------------------------------------------------------------------------------------------------|----------------------------------------------------------------------------------------------------------------------------------------------------------------------------------------------------------------------------------------------------------|-------------------------------------------------------------------------------------------------------------------------------|-----------------------------------------------------------------------------------------------------------------------------------------------------------|
| <ol style="list-style-type: none"> 1. Geographic coverage expanded to 12 provinces in the PRC including Shanxi, Jilin, Henan, Hubei, Jiangsu, Liaoning, Fujian, Yunnan, Shandong, Jiangxi, Zhejiang and Hebei by the end of 2001 | <ol style="list-style-type: none"> 1. Geographic coverage expanded to Anhui province in the PRC in January 2002 2. Checkpoint System and ePolice were certified as in conformity with the ISO 9001: 2000 standard in August 2002 | <ol style="list-style-type: none"> 1. Geographic coverage expanded to Sichuan province in the PRC in June 2003 | <ol style="list-style-type: none"> 1. The operation of video security system solutions in Yizheng began to generate income for the Company |
|-------------------------------------------------------------------------------------------------------------------------------------------------------------------------------------------------------------------------------------------------|----------------------------------------------------------------------------------------------------------------------------------------------------------------------------------------------------------------------------------------------------------|-------------------------------------------------------------------------------------------------------------------------------|-----------------------------------------------------------------------------------------------------------------------------------------------------------|

Customs logistics monitoring sector

- | | | | |
|--|-----------------------------------------------------------------------------------------------------------------------------------------------------------------------------------------------------------------------|-----------------------------------------------------------------------------------------------------------------------------------------------------------------------------------|----------------------------------------------------------------------------------------------------------------------------------------|
| | <ol style="list-style-type: none"> 1. Became the contractor of Distributive Intelligent Customs Logistics Monitoring Project (分佈式智能海關物流監控項目) of the State Technology Plan (國家科技攻關計劃) in September 2002 | <ol style="list-style-type: none"> 1. 19 out of 38 State-level EPZs in the PRC used the Company's customs logistics monitoring system solutions by the end of 2003 | <ol style="list-style-type: none"> 1. Business coverage expanded to bonded area of industrial parks (工業園保稅區) in the PRC |
|--|-----------------------------------------------------------------------------------------------------------------------------------------------------------------------------------------------------------------------|-----------------------------------------------------------------------------------------------------------------------------------------------------------------------------------|----------------------------------------------------------------------------------------------------------------------------------------|

Procuratorial sector

- | | |
|--|----------------------------------------------------------------------------------------------------------------------------------------------------------------------------------------------------------------------------------------------------------------|
| | <ol style="list-style-type: none"> 1. The Procuratorate-oriented Evidence-displaying System was used in procuratorates in 18 provinces and municipalities in the PRC 2. The procuratorial sector of business was sold in December 2002 |
|--|----------------------------------------------------------------------------------------------------------------------------------------------------------------------------------------------------------------------------------------------------------------|

STATEMENT OF ACTIVE BUSINESS PURSUITS

**For the year ended
31 December 2001**

**For the year ended
31 December 2002**

**For the year ended
31 December 2003**

**For the period
from 1 January
2004 to the Latest
Practicable Date**

Research and product development

Traffic monitoring and control sector

- | | | | | | | | |
|----|---------------------------------------------------------------------------------------------------------------------------------------------|----|--------------------------------------------------------------------------------------------------------------------------------------------------------------------------------------------------------|----|-------------------------------------------------------------------------------------------------------------------------------------------------------------------------------------------------------------------------------------------------------------|----|-------------------------------------------------------------------------------------------------------------------------------------------------------------------------------------------------------------------------|
| 1. | Completed the feasibility study of Highway Traffic Control Reference Data Monitoring and Inspecting System (高速公路交通控制參數檢測系統) in October 2001 | 1. | Commenced the R&D of Mobile Vehicles Inspection Police System (移動式車輛緝查系統) in August 2002 | 1. | Commenced the R&D of Police Inspection and Reporting Post Information Management System (警察查報站信息管理系統), a new generation of police enquiry post information system, in June 2003 | 1. | Commenced the R&D of the Police Inspection and Reporting Post Integrated Information System (警務查報站綜合信息系統), an upgraded version of the Police Inspection and Reporting Post Information Management System, in March 2004 |
| 2. | Completed the feasibility study of e-Police Photo Management System (電子警察照片管理系统) in December 2001 | 2. | Completed the R&D of EPV1000 ePolice (EPV1000電子警察) in April 2002 | 2. | Commenced the R&D of VR4000 Series Embedded Highway Vehicles Monitoring and Recording System (VR4000系列嵌入式公路車輛監測與記錄系統), an upgraded version of Highway Checkpoint Inspection System that possess automatic car plate recognition function, in September 2003 | | |
| | | 3. | Commenced the R&D of EPV2000 ePolice (EPV2000電子警察), an ePolice with an Auxiliary Lighting System, in August 2002 | | | | |
| | | 4. | Completed the feasibility study of Taxi Image Alarm System (出租車圖像報警系統), a security system for vehicles performing visual monitoring, wireless image transmission and emergency alarm, in November 2002 | 3. | Commenced the R&D of EPV3000 ePolice (EPV3000電子警察), an upgraded version of EPV2000 ePolice with encrypted software and additional automatic image deletion function, in October 2003. | | |

Customs logistics monitoring sector

- | | | | | | | | |
|----|-----------------------------------------------------------------------------------------------------------------------------------------------------------------------------------------------------------------------------------|----|------------------------------------------------------------------------------------------------------------------------------------------------------------------------------------------------------------------------------------------------|----|-------------------------------------------------------------------------------------------------------|----|-----------------------------------------------------------------------------|
| 1. | Completed the R&D of Customs Logistics Monitoring System V2.0 (海關物流監控系統 V2.0), an inspection system that verifies the basic information of cargos against the declaration submitted to the Customs at the EPZs, in September 2002 | 1. | Commenced the R&D of an upgraded version of the Customs Logistics Monitoring System (海關物流監控系統) which is connectable to the database of the Customs and compatible with various platforms and system solutions used by the Customs, in May 2003 | 1. | Commenced the R&D of the Headquarters Automatic Monitoring Centre System (總署無人值守監控中心系統) in March 2004 | 2. | Commenced the R&D of the Electronic Clearance System (電子關封系統) in April 2004 |
| | | 2. | Commenced the R&D of Digital Video Recording and Image Capturing Transmission System (數碼攝像一體拍攝傳輸系統), an all-in-one image capturing and transmission system, in October 2003 | | | | |

STATEMENT OF ACTIVE BUSINESS PURSUITS

For the year ended 31 December 2001	For the year ended 31 December 2002	For the year ended 31 December 2003	For the period from 1 January 2004 to the Latest Practicable Date
----------------------------------------	----------------------------------------	----------------------------------------	----------------------------------------------------------------------------

Technology and product development

Traffic monitoring and control sector

- | | | | |
|-----------------------------------------------------------------------------------------------------------------------------------------------------------------------------------------------------------------------------------------------------------------------------------------------------------------------------|--------------------------------------------------------------------------------------------------------------------------------------------------------------------------------------------------------------------------------------------------------------------------------------------------------------------------------------------------------------------------------------------------------------------------|------------------------------------------------------------------------------------------------------------------------------------------------------------------------------------------------------------------------------------------------------------------|--------------------------------------------------------------------------------------------------------------------------------------------------------|
| <ol style="list-style-type: none"> 1. Launched EP3040 Digital ePolice (EP3040型數碼電子警察) in September 2001 2. Launched VR3000 Series Highway Vehicles Intelligent Monitoring and Recording System (with motor car plate identification function) (VR3000系列公路車輛智能化監測與記錄系統(帶車牌自動識別功能)) in September 2001 | <ol style="list-style-type: none"> 1. Launched EPV1000 ePolice (EPV1000型電子警察) in May 2002 2. Launched Provincial Highway Vehicle Monitoring and Recording System (省級公路車輛監測記錄系統), a provincial network inspection system that automatically identify and report vehicles that are "blacklisted" by the provincial/ municipal traffic police of the Ministry of the Public Security, in April 2002 | <ol style="list-style-type: none"> 1. Launched Intelligent Mobile Vehicles Inspection System (移動式車輛緝查系統) in June 2003 2. Launched the Police Inspection and Reporting Post Information Management System (警務查報站信息管理系統) in September 2003 | <ol style="list-style-type: none"> 1. Launched Embedded Highway Vehicles Monitoring and Recording System (嵌入式公路車輛監測與記錄系統) in March 2004 |
|-----------------------------------------------------------------------------------------------------------------------------------------------------------------------------------------------------------------------------------------------------------------------------------------------------------------------------|--------------------------------------------------------------------------------------------------------------------------------------------------------------------------------------------------------------------------------------------------------------------------------------------------------------------------------------------------------------------------------------------------------------------------|------------------------------------------------------------------------------------------------------------------------------------------------------------------------------------------------------------------------------------------------------------------|--------------------------------------------------------------------------------------------------------------------------------------------------------|

Customs logistics monitoring sector

- | | |
|-----------------------------------------------------------------------------------------------------------------------------------------------------------------------------------------------------------------------------------------------------------------|-----------------------------------------------------------------------------------------------------------------------------------------------------|
| <ol style="list-style-type: none"> 1. Launched Customs Logistics Management System V2.0 (海關物流管理系統V2.0), an upgraded version of Customs Checkpoint Automatic Inspection System with database enquiry and data analysis functions, in October 2002 | <ol style="list-style-type: none"> 1. Launched Export Processing Zone Video Supervision Alarming System (出口加工區電視監控報警系統) in June 2003 |
|-----------------------------------------------------------------------------------------------------------------------------------------------------------------------------------------------------------------------------------------------------------------|-----------------------------------------------------------------------------------------------------------------------------------------------------|

STATEMENT OF ACTIVE BUSINESS PURSUITS

	For the year ended 31 December 2001	For the year ended 31 December 2002	For the year ended 31 December 2003	For the period from 1 January 2004 to the Latest Practicable Date
Market development				
Traffic monitoring and control sector	<ol style="list-style-type: none"> 1. Successful bidder in the tender exercise in the PRC for the Nanjing Public Security Bureau and Traffic Management Bureau ePolice Project (南京市公安局交通管理局闖紅燈自動記錄儀系統項目) in September 2001 2. Successful bidder in the tender exercise in the PRC for the Security Checkpoint System of the Transport Management Bureau under the Nanjing Public Security Bureau (南京市公安局交通管理局卡口監控系統) in September 2001 3. Successful bidder in the tender exercise in the PRC for ePolice of the Traffic Police Station of the Public Security Bureau in Zhangjiagang (張家港公安局交警大隊電子警察系統) in September 2001 4. Signed contract with the Traffic Management Scientific and Research Centre of the Ministry of Public Security (公安部交通管理科學研究所) for the ePolice in Chongqing in November 2001 	<ol style="list-style-type: none"> 1. Successful bidder in the tender exercise in the PRC for the Shandong Public Security Bureau and Traffic Management Bureau Security Checkpoint Monitoring System Project (山東省公安厅交通警察總隊公路車輛監測記錄系統項目) in April 2002 	<ol style="list-style-type: none"> 1. Successful bidder in the tender exercise in the PRC for the Command Centre integrated with the Police Inspection and Reporting Post Monitoring System Project of Nanjing Public Security Bureau (南京市公安局指揮中心綜合警務查報站監控系統項目) in May 2003 2. Signed contract with the Deyang Traffic Police Sub-unit of Public Security Bureau of Sichuan Province (四川德陽市公安局交警支隊) for the Mobile Vehicles Inspection System in June 2003 3. Signed co-operation agreement with the Yizhang Traffic Police Sub-unit of Jiangsu Province (江蘇儀征市交警支隊) in March 2003 4. Signed co-operation agreement with the Jintan City Public Securities Bureau (金壇市公安局) in November 2003 	<ol style="list-style-type: none"> 1. Successful bidder in the tender exercise in the PRC for the Taian Public Security Bureau Traffic Command Centre Project (泰安市公安交通指揮中心系統項目) in March 2004 2. Successful bidder in the tender exercise in the PRC for the Intelligent Security Checkpoint System of the Zhenjiang Public Security Bureau Traffic Police Sub-unit (鎮江市公安交通(巡邏)警察支隊道路交通治安卡口智能監控系統) in April 2004

STATEMENT OF ACTIVE BUSINESS PURSUITS

	For the year ended 31 December 2001	For the year ended 31 December 2002	For the year ended 31 December 2003	For the period from 1 January 2004 to the Latest Practicable Date
Customs logistics monitoring sector	<ol style="list-style-type: none"> Became the contractor of Beijing Tianzhu EPZ Customs Logistics Monitoring System (北京天竺出口加工區物流監管系統) in March 2001 Signed contract with the Nanjing Xinshengxu Customs (南京新生圩海關) for the Customs Logistics Monitoring System in May 2001 Became the contractor of Xiamen EPZ Container Automatic Identification Sub-system (廈門出口加工區集裝箱自動識別驗核系統) in 2001 	<ol style="list-style-type: none"> Successful bidder in the tender exercise in the PRC for the purchase of the Electronic Vehicle Licence Plate Recognition System Project of the General Administration of Customs of the PRC (中華人民共和國海關總署電子車牌識別系統採購項目) in November 2002 	<ol style="list-style-type: none"> Successful bidder in the tender exercise in the PRC for Qinhuangdao export Processing Zone System engineering project (秦皇島出口加工區系統工程項目) in March 2003 Successful bidder in the tender exercise in the PRC for the Checkpoint Facilities Management System Procurement Project of the General Administration of the PRC (中華人民共和國海關總署卡口設備管理採購項目) in November 2003 	<ol style="list-style-type: none"> Became the contractor of Suzhou Industrial Park Export Processing Zone (Area B) Customs Logistics Monitoring System (蘇州工業區出口加工區B區卡口海關物流監控系統) in March 2004 Became the contractor of Bonded Logistics Area of Suzhou Industrial Park Customs Logistics Monitoring System (蘇州工業園區保稅物流園物流管理系統卡口監控子系統) in April 2004
Revenue and profit				
Traffic monitoring and control sector	<ol style="list-style-type: none"> The audited turnover and gross profit of this sector was approximately RMB15.7 million and RMB4.6 million respectively 	<ol style="list-style-type: none"> The audited turnover and gross profit of this sector was approximately RMB44.3 million and RMB16.0 million respectively 	<ol style="list-style-type: none"> The audited turnover and gross profit of this sector was approximately RMB46.7 million and RMB25.1 million respectively 	<ol style="list-style-type: none"> Up to 30 April 2004, the unaudited turnover and gross profit of this sector was approximately RMB12.5 million and RMB5.8 million respectively
Customs logistics monitoring sector	<ol style="list-style-type: none"> The audited turnover and gross profit of this sector was approximately RMB14.2 million and RMB5.4 million respectively 	<ol style="list-style-type: none"> The audited turnover and gross profit of this sector was approximately RMB16.5 million and RMB7.5 million respectively 	<ol style="list-style-type: none"> The audited turnover and gross profit of this sector was approximately RMB15.1 million and RMB7.6 million respectively 	<ol style="list-style-type: none"> Up to 30 April 2004, the unaudited turnover and gross profit of this sector was approximately RMB2.4 million and RMB1.0 million respectively
Procuratorial sector	<ol style="list-style-type: none"> The audited turnover and gross profit of this sector was approximately RMB2.8 million and RMB677,000 respectively 	<ol style="list-style-type: none"> The audited turnover and gross profit of this sector was approximately RMB1.3 million and RMB421,000 respectively 		

STATEMENT OF ACTIVE BUSINESS PURSUITS

For the year ended 31 December 2001	For the year ended 31 December 2002	For the year ended 31 December 2003	For the period from 1 January 2004 to the Latest Practicable Date
----------------------------------------	----------------------------------------	----------------------------------------	----------------------------------------------------------------------------

Sales and marketing

- | | | | |
|---------------------------------------------------------------------------------------------------------------------------------------------------------------------------|--------------------------------------------------------------------------------------------------------------------------------------------------------------------------|---------------------------------------------------------------------------------------------------------------------------------------------------------------------------|----------------------------------------------------------------------------------------------------------------------------------------------------------------------------------------------------|
| <p>1. The Group's sales and marketing team had 16 personnel as at 31 December 2001</p> | <p>1. The Group's sales and marketing team had 40 personnel as at 31 December 2002</p> | <p>1. The Group's sales and marketing team had 36 personnel as at 31 December 2003</p> | <p>1. The Group's sales and marketing team had 36 personnel as at the Latest Practicable Date</p> |
| <p>2. The audited marketing and promotional expenses were approximately RMB5.3 million, representing approximately 16.1% of the turnover of the Group during the year</p> | <p>2. The audited marketing and promotional expenses were approximately RMB4.7 million, representing approximately 7.6% of the turnover of the Group during the year</p> | <p>2. The audited marketing and promotional expenses were approximately RMB7.2 million, representing approximately 11.6% of the turnover of the Group during the year</p> | <p>2. Up to 30 April 2004, the unaudited marketing and promotional expenses were approximately RMB3.0 million, representing approximately 20.0% of the turnover of the Group during the period</p> |

Research and development

- | | | | |
|----------------------------------------------------------------------------------------------------------------------------------------------------|--------------------------------------------------------------------------------------------------------------------------------------------------------|--------------------------------------------------------------------------------------------------------------------------------------------------------|------------------------------------------------------------------------------------------------------------------------------------------------------------------------------|
| <p>1. The Group's R&D team had 22 personnel as at 31 December 2001</p> | <p>1. The Group's R&D team had 37 personnel as at 31 December 2002</p> | <p>1. The Group's R&D team had 35 personnel as at 31 December 2003</p> | <p>1. The Group's R&D team had 35 personnel as at the Latest Practicable Date</p> |
| <p>2. The audited R&D expenses were approximately RMB877,000, representing approximately 2.7% of the turnover of the Group during the year</p> | <p>2. The audited R&D expenses were approximately RMB1.7 million, representing approximately 2.7% of the turnover of the Group during the year</p> | <p>2. The audited R&D expenses were approximately RMB2.2 million, representing approximately 3.6% of the turnover of the Group during the year</p> | <p>2. Up to 30 April 2004, the unaudited R&D expenses were approximately 1.1 million, representing approximately 7.3% of the turnover of the Group during the period</p> |

STATEMENT OF BUSINESS OBJECTIVES

OVERALL BUSINESS OBJECTIVES AND STRATEGIES

The Group aims to become a leading provider and operator of video security system solutions in the traffic monitoring and control sector and the customs logistics monitoring sector. To ascertain the prospect and potential of the Group's business in the provision of video security system solutions in the traffic monitoring and control sector and the customs logistics monitoring sector, the Company has engaged CCID Data at a consideration of RMB105,000 in preparing a market research report called Digitalisation of Traffic, Customs and Government sectors in the PRC – Current Investment Conditions and Trends (中國交通、海關、政府行業信息化投資現狀與趨勢) in respect of years 2002 to 2006 (the "Research Report").

The Research Report was issued in October 2002 and forecasts that total investment in the PRC information service market would increase from RMB50.4 billion in 2002 to RMB136.2 billion in 2006 with a compound annual growth rate of approximately 28.2%. According to the Research Report, investments in the intelligent transportation market in the PRC are estimated to increase from approximately RMB9.2 billion in 2002 to approximately RMB20.1 billion in 2005, representing a compound annual growth rate of approximately 29.8%. General Customs Administration of the PRC (中華人民共和國海關總署) also estimates that investment in informationalisation for the customs logistics monitoring sector in the PRC will be approximately RMB13.2 billion during the period from 2001 to 2005, out of which more than RMB5.2 billion will be invested in logistics control, approximately 2.3 billion in electronic services of customs and approximately RMB1.8 billion in electronic services of ports.

In view of the findings of the Research Report, the Group endeavours to continue its focus in the traffic monitoring and control sector and the customs logistics monitoring sector. The Group's system solutions assist the local public security bureaus in the PRC to identify suspected vehicles, locations of reported lost vehicles and undeclared cargos. Such identification function enables the local public security bureaus in the PRC to monitor public security effectively and to reduce possible law-violating activities. The Group will leverage on the opportunities arising from government digitalisation projects and city digitalisation projects to provide information value-added services to customers, with a view to maintaining its position in the traffic monitoring and control sector and the customs logistics monitoring sector.

The Group intends to achieve its business objectives by implementing the following strategies:

- Strengthen the research, development and application of the core technologies based on video graphic technology and to maintain its position in the relevant market. Emphasis is placed on the formulation of and compliance with self-developed product standards which had registered with the Standardisation Department of the Nanjing Quality and Technology Supervision Bureau (南京市質量技術監督局標準化處), a domestic official organisation responsible for implementing and supervising national, local and industrial product standards.
- Capitalise on the Group's technical advantage in developing technologies of real-time video capture, video encoding and decoding, video transmission, video identification and web services to develop a series of system solutions.
- Strengthen the Group's management quality and pursue the achievement of ISO9001 quality certification in order to promote corporate image and recognition of its system solutions.
- Build a corporate culture by following the business orientation of the Group, i.e. value the technical expertise of its professionals and emphasise the relationship with its customers to nurture team spirit and adapt to rapid market changes and development of the technology industry.
- Establish a research institute for new technologies and system solutions to improve the technological innovation capacity and upgrade its core technology, which will be financed by government subsidies and the Group's internal resources.

STATEMENT OF BUSINESS OBJECTIVES

- Strengthen the relationship and co-operation with reputable academic institutions and research institutes. Save as disclosed in this prospectus, the Group currently is not carrying out any negotiation with any academic institutions and research institutes.

BASES AND ASSUMPTIONS

In formulating the Group's business objectives, the Directors have evaluated the market potential of the Forward Looking Period with reference to the Group's development as stated under the section headed "Statement of active business pursuits" in this prospectus and have made reference to the trend of the industry and previous experience of the Directors. The Directors have made the following principal assumptions in making such assessments and formulation:

- There will be no material changes in the rates of taxation and bases of taxation that are currently applicable to the Group;
- There will be no material changes in the legal conditions in the PRC that will adversely affect the Group's business and operations.
- There will be no material change in the interest rates and exchange rates in the PRC that will adversely effect the business of the Group;
- The PRC government will continue to encourage and promote the development of the information service industry;
- There will be no material change in the funding requirement for each of the near term development strategies described herein as estimated by the management of the Group;
- external financing will be readily available to the Group;
- There will be no material changes to the Group's management;
- The Group can retain and employ suitable talents; and
- There will be no disasters, natural, political or other force majeure events which will severely hinder the Group's business or operations or cause significant losses, damages or destruction to the Group's properties or equipment, nor will there be any unexpected factors which will have material adverse effects on the Group.

IMPLEMENTATION PLAN

The Group endeavours to become a prominent video security system solutions provider and operator in the traffic monitoring and control sector and the customs logistics monitoring sector in the PRC.

The following are the specific business objectives of the Group for the period from the Latest Practicable Date to 31 December 2004 and for each of the six-month period during the two years ending on 31 December 2006:

Product development and upgrade

In accordance with the Group's R&D initiatives and strategies, the Group intends to concentrate its efforts on developing and upgrading its video security system solutions and the necessary core technologies for its technology based products, with a view to raising the quality of products, the reliability of the systems, technology barriers of the industry and facilitating the launch of new generations of products.

STATEMENT OF BUSINESS OBJECTIVES

Item	From the Latest Practicable Date to 30 June 2004	For the six months ending 31 December 2004	For the six months ending 30 June 2005	For the six months ending 31 December 2005	For the six months ending 30 June 2006	For the six months ending 31 December 2006
Traffic monitoring and control sector	Video Camera Type ePolice (capable of taking numerous photos, recreating driving routes of violating vehicles) Products: Highway Vehicle Monitoring Web Enquiry System, Remote and Warning System	Multi-function Electronic Police (capable of providing traffic light signaling, law violation monitoring, speeding detection and traffic flow statistics) Product: Special Highway Sections Regulation and Detection System (speeding, trespassing traffic light signal and wrong lane)	Mobile Vehicle Monitoring System (checking criminals' vehicles, vehicles evading yearly examination and defaulting penalties) Product: Motor Vehicle Safety Protection and Surveillance System	Inbuilt Highway Vehicles Monitoring and Recording System, Embedded Electronic Police System Product: Portable and Mobile Speeding Warning System	Integrated Digital ePolice (using CCD chips and lens developed by the Company, with high identification rate) Product: Taxi Safety Protection System	Automatic Vehicle Licence Plate Identification Digital ePolice (an upgraded version of Integrated Digital ePolice capable of identifying registration numbers on vehicle licence plates automatically) Product: RFID Vehicles In-and-out Management System
Customs logistics monitoring sector	Customs Operation Data Integration Platform Customs Vehicle & Cargo Supervision System for Cargo Transit Operation	Customs Inbuilt Image Collection Equipment for Yard Supervision	Customs Supervision, Video Information Intelligent Processing System for Customs Monitoring	Identity Card Management System in Customs Logistics Supervision	Customs Passage Monitoring and Control Centre System (an integrated system solution that enable automation of monitoring and control over the passages of customs)	Export Processing Enterprise Network Monitoring System (an integrated system solution that enables (i) supervision of customs application procedures, (ii) monitoring and control of export of equipment, facilities and processed products from enterprises in the EPZs, and (iii) data sharing through an intranet)

Sales and marketing

Item	From the Latest Practicable Date to 30 June 2004	For the six months ending 31 December 2004	For the six months ending 30 June 2005	For the six months ending 31 December 2005	For the six months ending 30 June 2006	For the six months ending 31 December 2006
Traffic monitoring and control sector	Upgrade the existing equipment of existing customers, promote products to potential customers	Advertise through major media, hold conferences and meetings, promote industry standards	Help the public security headquarters to upgrade the existing Traffic Rule Violation Punishment System and promote new products to them	Advertise through major media, hold regular trainings and trade fairs with existing customers	Target on 110 public security command centres all over the country, promote the Group's products according to the requirements of city security system	Promote the "Embedded Highway Checkpoint Inspection System" and the "Embedded ePolice" to public security authorities across the country
Customs logistics monitoring sector	Place advertisement on the magazine "PRC Customs" once per quarter	Establish business representative offices in Fujian Province and Liaoning Province	Focus on the holding of business conferences in Beijing, Shenzhen and Shanghai	Promote new products to the General Administration of Customs	Hold seminars/ briefing sessions on the Group's products for the customs of major cities of the country	Hold seminars with the Customs to introduce the Group's customs logistics monitoring product/system solutions to other customs authorities

STATEMENT OF BUSINESS OBJECTIVES

Allocation of human resources

The Directors intend to increase the number of staff (especially staff for research and development and marketing departments) in order to carry out the Group's business plans. As at the Latest Practicable Date, the Group employed 172 staff in the PRC and staff that engaged in R&D accounts for approximately 20% of the total staff members. As the Group possesses sufficient human resources for research and development, the Directors believe that the Group has the ability to develop new information technology solutions for its customers. With the gradual implementation of business development plan, the Directors expect that, assuming the business of the Group develops smoothly, the total number of employees to be employed by the Group will be as follows:

	As at the Latest Practicable Date	As at 30 June 2004	As at 31 December 2004	As at 30 June 2005	As at 31 December 2005	As at 30 June 2006	As at 31 December 2006
Management and general administration	36	43	45	45	48	50	50
Research and development	35	45	55	60	70	80	85
Sales and marketing	36	37	40	42	45	50	52
Technical support service	65	65	70	75	78	80	88
Total	172	190	210	222	241	260	275

The Group will continue to enhance its internal operation, for example, to modify and improve its existing management procedures, to reinforce its technical training for new recruits and to ensure their familiarity with the Group's corporate culture.

STATEMENT OF BUSINESS OBJECTIVES

Costs of implementation of business objectives

The estimated costs of implementing the Group's business objectives as stated in this section are as follows:

	From the Listing Date to 30 June 2004 <i>HK\$ million</i>	For the six months ending 31 December 2004 <i>HK\$ million</i>	For the six months ending 30 June 2005 <i>HK\$ million</i>	For the six months ending 31 December 2005 <i>HK\$ million</i>	For the six months ending 30 June 2006 <i>HK\$ million</i>	For the six months ending 31 December 2006 <i>HK\$ million</i>	Total <i>HK\$ million</i>
To be funded by the net proceeds from the Placing of the New H Shares (Note 1)							
R&D and upgrading of system solutions							
– Traffic monitoring and control sector	0.2	1.7	1.8	1.8	1.8	1.8	9.1
– Customs logistics monitoring sector	–	0.4	0.4	0.5	0.5	0.5	2.3
Construction of information platform							
– Traffic monitoring and control sector	0.1	0.9	0.9	0.9	1.0	1.0	4.8
– Customs logistics monitoring sector	–	0.2	0.2	0.2	0.3	0.3	1.2
Launching of new system solutions							
– Traffic monitoring and control sector	0.2	0.4	0.5	0.6	0.6	0.6	2.9
– Customs logistics monitoring sector	0.1	0.1	0.1	0.1	0.1	0.2	0.7
Purchase of additional equipment and/or facilities for commercialisation of system solutions	0.2	1.7	1.7	1.8	1.8	1.8	9.0
Expansion of sales and distribution network	0.2	1.1	1.1	1.2	1.2	1.2	6.0
Sub-total	<u>1.0</u>	<u>6.5</u>	<u>6.7</u>	<u>7.1</u>	<u>7.3</u>	<u>7.4</u>	<u>36.0</u>
Working capital	<u>–</u>	<u>1.1</u>	<u>1.1</u>	<u>1.1</u>	<u>1.1</u>	<u>1.1</u>	<u>5.5</u>
Total	<u><u>1.0</u></u>	<u><u>7.6</u></u>	<u><u>7.8</u></u>	<u><u>8.2</u></u>	<u><u>8.4</u></u>	<u><u>8.5</u></u>	<u><u>41.5</u></u>

Note:

- Based on the Placing Price of HK\$2.70 per H Share (being the lower limit of the indicative Placing Price range as set out in this prospectus)

STATEMENT OF BUSINESS OBJECTIVES

REASONS FOR THE PLACING AND THE USE OF PROCEEDS

The net proceeds from the Placing of the New H Shares, after deducting related listing expenses and underwriting commission, are estimated to be approximately HK\$41.5 million based on the Placing Price of HK\$2.70 per H Share, being the lower limit of the indicative Placing Price range as set out in this prospectus. The Group presently intends to apply approximately HK\$21.0 million of such net proceeds in the R&D and upgrading of system solutions, construction of information platform and launching of new system solutions. Details and the breakdown of the usage of the net proceeds from the Placing of the New H Shares are set out as follows:

- Approximately HK\$11.4 million will be invested in the R&D and upgrading of system solutions, including:
 - (i) approximately HK\$9.1 million for the traffic monitoring and control sector
 - (ii) approximately HK\$2.3 million for the customs logistics monitoring sector
- Approximately HK\$6.0 million will be invested in the construction of information platform, including:
 - (i) approximately HK\$4.8 million for the traffic monitoring and control sector
 - (ii) approximately HK\$1.2 million for the customs logistics monitoring sector
- Approximately HK\$3.6 million will be invested in the launching of new system solutions, including:
 - (i) approximately HK\$2.9 million for the traffic monitoring and control sector
 - (ii) approximately HK\$0.7 million for the customs logistics monitoring sector
- Approximately HK\$9.0 million will be invested in the purchase of additional equipment and/or facilities for commercialisation of system solutions
- Approximately HK\$6.0 million will be invested in the expansion of sales and distribution network
- Approximately HK\$5.5 million will be used as general working capital

The Placing Price, which is expected to be determined on or before the Price Determination Date, is not expected to be lower than HK\$2.70 but will not be more than HK\$4.60 per H Share. In the event that the net proceeds from the Placing of the New H Shares are not sufficient to cover the abovementioned plans for the use of proceeds, the Group intends to finance the remaining funds required through various financing alternatives, including, utilising its internal resources, obtaining additional equity financing or debt financing or through a combination of those methods. The Directors consider that the net proceeds from the Placing of the New H Shares, together with the Group's internally generated funds, will be sufficient to finance the implementation of the business plans of the Group as stated under the section headed "Statement of business objectives" in this prospectus.

STATEMENT OF BUSINESS OBJECTIVES

Should the Placing Price be fixed at HK\$4.60 per H Share, being the upper limit of the indicative Placing Price range as set out in the prospectus, the additional net proceeds from the Placing of the New H Shares, after deducting related listing expenses and underwriting commission, are estimated to be approximately HK\$35.5 million and will be applied by the Group in the same manner and in the same proportion as shown above.

To the extent that the net proceeds from the Placing of the New H Shares are not immediately applied for the above purposes, it is the present intention of the Directors that such net proceeds will be placed on short-term deposits.

In the event that any part of the business plans of the Group does not materialise or proceed as planned, the Directors will evaluate the situation and may reallocate the intended funding to other business plans and/or to new projects of the Group and/or to hold such funding as short-term deposits so long as the Directors consider it to be in the best interests of the Group and the Shareholders taken as a whole. The Company will make an announcement and comply with other applicable requirements in accordance with the GEM Listing Rules if this occurs.

DIRECTORS, SUPERVISORS, SENIOR MANAGEMENT AND STAFF

DIRECTORS

The Board consists of 10 Directors, three of which are executive Directors, four of which are non-executive Directors and the remaining three are independent non-executive Directors. The Directors are appointed at a shareholders' meeting of the Company for a term of three years, renewable upon re-election and re-appointment. The functions and duties conferred on the Board mainly include (i) convening shareholders' meetings and reporting its work at the shareholders' meetings; (ii) implementing the resolutions of shareholders' meetings; (iii) devising the Group's business plans and investment plans; (iv) formulating the Group's annual budget and final accounts, preparing the Group's proposals for dividend and bonus distributions and for the increase or reduction of capital as well as exercising other powers, functions and duties as conferred by the Articles of Association.

EXECUTIVE DIRECTORS

Mr. Sha Min (沙敏先生), aged 39, is an executive Director and the chairman of the Company. He is responsible for devising the Group's overall strategies and policies. Mr. Sha obtained a master degree in engineering from Southeast University (東南大學) in 1990. Mr. Sha was firstly appointed as a Director in December 1999. He will be directly interested in 0.7% of the registered capital of the Company immediately after the Placing. Mr. Sha was conferred the titles of Jiangsu Province Outstanding Young Entrepreneur (江蘇省優秀青年企業家) and Nanjing Ten Outstanding Young Entrepreneur (南京十佳青年經營管理者) in 2000 and 2001 respectively. Mr. Sha was elected as a committee member of the Chinese People's Political Consultative Conference of the Nanjing Committee (中國人民政治協商會議南京市委員會委員) in January 2003.

Mr. Chang Yong (常勇先生), aged 37, is the general manager of the Company since December 2000. He is responsible for implementing the Group's strategies and business plans. He obtained a master degree in computer application studies from Harbin Polytechnical University (哈爾濱工業大學) in March 1990. Mr. Chang worked for the computer centre of the Nanjing Bureau of Finance (南京市財政局) from 1990 to 1992. Mr. Chang became the vice general manager of Sample Group in June 1993 and was mainly responsible for the expansion, operation and management of Sample Group's business. He was appointed as an executive director and the general manager of Sample System in December 1997. Mr. Chang was elected as a member of the Chinese People's Political Consultative Committee of Xuanwu District in Nanjing City (中國人民政治協商委員會南京市玄武區委員) in 1998. Mr. Chang was firstly appointed as a Director in December 1997.

Mr. Guo Ya Jun (郭亞軍先生), aged 44, is an executive Director, deputy general manager and financial controller of the Company. He is responsible for supervising the company's accounting department and financial affairs. He graduated from the Faculty of Agricultural Economy at Anhui Agricultural College (安徽農學院) in August 1982 with a bachelor degree in agricultural economics. Mr. Guo worked for the Finance Bureau of Lingbi County in Anhui Province (安徽靈璧縣財政局) from 1982 to 1992. He worked for the Nanjing Jintai Building Materials Development Company (南京金台建材開發有限公司) between 1993 and 1996. Mr. Guo was appointed as the finance manager of Sample Group and Sample System in October 1996 and became the Company's director of finance and deputy general manager in December 2000. He is currently mainly responsible for the financial and administrative management of the Group. He was firstly appointed as a Director in December 1999.

DIRECTORS, SUPERVISORS, SENIOR MANAGEMENT AND STAFF

NON-EXECUTIVE DIRECTORS

Mr. Zhao Jing Cheng (趙竟成先生), aged 58, is a non-executive Director. He graduated from the Faculty of Automatic Control of Southeast University (東南大學) in 1969. Mr. Zhao completed the postgraduate study in Nanjing University of Science and Technology (南京理工大學) in 1998, and obtained an MBA degree from Macau Science and Technology University (澳門科技大學) in January 2002. He joined Huadong Electronics Factory (華東電子管廠) in August 1970 and is now the president and chairman of the board of Huadong Technology. Mr. Zhao was firstly appointed as a Director in July 2000.

Mr. Zhang Yin Qian (張銀千先生), aged 48, is a non-executive Director. He graduated from Wuxi School of Wireless Electronics Industry (無錫市無線電工業學校) in July 1978. Mr. Zhang joined Huadong Electronics Factory (華東電子管廠) in August 1978 and is now the supervisor of Huadong Technology. Mr. Zhang was firstly appointed as a Director in December 2000.

Mr. Zhao Wen (趙文先生), aged 35, is a non-executive Director. He graduated from the College of International Relationship (國際關係學院) in 1991. He formerly worked for Nanjing Hong Kong Chang Jiang Company Limited (南京香港長江有限公司) from July 1991 to February 1993 and was the general manager of Nanjing Daya Art Company Limited (南京大雅藝術有限公司) from April 1993 to April 1994. He worked with Jiangsu Social Science Academy (江蘇社會科學院) from May 1994 to August 1994. Mr. Zhao joined Nanjing Zhongbei in September 1994 and is now the deputy general manager of Nanjing Zhongbei. He was firstly appointed as a Director in December 1999.

Mr. Zhu De Xiang (朱德祥先生), aged 58, is a non-executive Director. He was a political instructor, head of the section and political commissioner of a division of the People's Liberation Army of the Nanjing Military Area Command (南京軍區部隊) between September 1965 and August 1991. Mr. Zhu joined Nanjing Zhongbei in August 1991 and is currently the secretary of the communist party of Nanjing Zhongbei. Mr. Zhu firstly was appointed as a Director in December 2000.

INDEPENDENT NON-EXECUTIVE DIRECTORS

Mr. Zhang Zhan (張展先生), aged 38, is an independent non-executive Director. He graduated from the Faculty of Computer Science at Wuhan University (武漢大學) and obtained a bachelor degree in 1989. Mr. Zhang is currently the general manager of the investment banking division of Jiangnan Securities Co. Ltd. (江南證券有限責任公司). Mr. Zhang was firstly appointed as a Director in December 1997.

Mr. Wang Wei (王煒先生), aged 44, is an independent non-executive Director. He graduated from the Department of Civil Engineering of the Southeast University (東南大學) with a bachelor degree in July 1982 and a master degree in February 1985. He then taught in the Transport Department of the Southeast University. Mr. Wang obtained a doctorate degree from Southeast University in structural engineering in May 1990. Mr. Wang has been the Head of the City Road Traffic Management (Clear Way Project) National professional Group of the Department of Public Security and Department of Construction (公安部/建設部城市道路交通管理'暢通工程'專家組長) since April 2000. Mr. Wang was appointed as an independent non-executive Director in November 2001.

Mr. Lau Shek Yau John (劉石佑先生), aged 56, is an independent non-executive Director. He was previously the managing director of United Distribution Services (Far East) Limited (a member of the Dodwell Group of Companies). Mr. Lau is active in cargo business and experienced in international trading. In 1985, he established United Distribution Services Far East Limited (華洋遠東貨運有限公司) which was subsequently sold. In 1990, Mr. Lau established Wide Shine Terminals Limited (宏光貨櫃碼頭有限公司), which was subsequently sold. Mr. Lau is the managing director of Cargo Services Far East Limited (嘉宏航運有限公司) and Far East Cargo Line which have overseas offices in the United Kingdom, Singapore, and the PRC. Mr. Lau is

DIRECTORS, SUPERVISORS, SENIOR MANAGEMENT AND STAFF

the director of Xinhaihua Enterprise Limited (香港新海華實業有限公司) and the chairman of Nanjing Xinhaihua Industry Company Limited (南京新海華實業有限公司). Mr. Lau was appointed as a committee member of the Chinese People's Political Consultative Committee of the Nanjing Committee (中國人民政治協商會議南京市委員會委員) in 2003. Mr. Lau was appointed as an independent non-executive Director in August 2003.

SUPERVISORS

Mr. Tian Tao (田濤先生), aged 56, is a Supervisor and chairman of the supervisory board of the Company. He graduated from the Department of Journalism with a bachelor degree in Journalism in Fudan University in January 1982. Mr. Tian was the vice director of the news department of Nanjing People's Broadcasting Station (南京人民廣播電台) between November 1983 and August 1984. During the period from August 1984 to April 1994, Mr. Tian acted as the head of the news department of Nanjing People's Broadcasting Station and was the Secretary of the party committee. Mr. Tian was appointed as the vice minister of the broadcasting department of Nanjing Municipal Commission of the Communist Party Committee (中共南京市委宣傳部) since 1994. Mr. Tian has been the head, chairman of the board and the secretary of the party committee of Nanjing Daily since December 2002. He was firstly appointed as a Supervisor in July 2000.

Mr. Sun Huai Dong (孫懷東先生), aged 36, is a Supervisor. He graduated from the Department of Radio Engineering (無線電工程系) of the Southeast University (東南大學) with a bachelor degree in July 1990. He worked for the State-owned Factory No. 772 (國營772廠) from 1990 to 1992. Mr. Sun was appointed manager of the sales department and general manager of Sample Industry during the period from 1993 to 2002. Mr. Sun has been the vice deputy general manager of Jiangsu Hai Te Man New Material Co., Ltd. (江蘇海特曼新材料有限公司) since 2002. He was firstly appointed as a Supervisor in December 1999.

Ms. Du Jin (杜瑾女士), aged 40, is a Supervisor elected by the staff members of the Company. She obtained an MBA degree from Asia International Open University (Macau) (亞洲澳門國際公開大學) in 2000. She formerly worked for Jiangsu Province Telecommunication Equipment Factory (江蘇省通信設備廠) from December 1985 to August 1993 and Nabisco Food (Suzhou) Company Limited Nanjing Branch (納貝斯克食品(蘇州)有限公司南京分公司) from July 1996 to July 1998. She joined the Company in August 1998 and is now the manager of the Company's customs affair department. She was firstly appointed as a Supervisor in December 1999.

INDEPENDENT SUPERVISORS

Mr. Dai Jian Jun (戴建軍先生), aged 33, is a Supervisor. He was educated in Jiangsu Public Security Professional School (江蘇公安專科學校) from September 1988 to July 1991. He worked for Southeast University (東南大學) in 1991. Mr. Dai was qualified as a lawyer in PRC in 1996. Mr. Dai has been a lawyer of Jiangsu Zhi Bang Law Firm (江蘇致邦律師事務所) since 1996. He was appointed as a Supervisor in August 2003.

Ms. Ma Lin Ping (馬林萍女士), aged 42, is a Supervisor. She graduated from the Correspondence School of the Communist Party of the PRC (中共中央黨校函授學院) in 1998. She was qualified as an accountant in PRC in 1994. Ms. Ma was an accountant of Nanjing Shi Cheng Certified Public Accountant (南京石城會計師事務所) from November 1995 to September 1999. She was qualified as a registered tax consultant and a registered asset valuer in PRC in 1999 and 2000 respectively. Ms. Ma was the director of Nanjing Shi Cheng Tax Consultants (南京石城稅務師事務所) since March 2000. She was appointed as a Supervisor in August 2003.

DIRECTORS, SUPERVISORS, SENIOR MANAGEMENT AND STAFF

SENIOR MANAGEMENT

Mr. Fu Yu Qing (富煜清先生), aged 65, is the Company's chief technical officer. He graduated from Southeast University (東南大學) in August 1961 and obtained a doctorate degree in Philosophy from the University of Laval in 1984. Mr. Fu was an instructor of the Faculty of Wireless Communications of Southeast University (東南大學) from September 1961 to December 1979. He was an associate professor, professor, director of teaching group, director of laboratory and general engineer of the research institute of Southeast University (東南大學) in different periods of time from January 1984 to July 1998. Mr. Fu joined Sample Group in September 1998 and is currently the vice president of Sample Group. Mr. Fu joined the Company and was appointed as the chief technical officer of the Company in December 2000.

Mr. Qi Tong Lin (祁同林先生), aged 38, is a technical expert of the Company's research institute and manager of electronic products division. He completed a four-year course in the Faculty of Wireless Communications of Southeast University (東南大學) in July 1987 and obtained a master degree in the Faculty of Automatic Control of the same university in February 1990. Mr. Qi was involved in R&D at Nanjing Computer Measure Equipment Company (南京電腦計量設備有限公司) from 1990 to 1992, and worked for Xinbo Medical Engineering Company (新博醫療器械實業電子有限公司) from 1992 to 1997. He was the assistant to the general manager and manager of engineering department of Sample Group between August 1997 and December 2000. Mr. Qi joined the Company in January 2001.

Mr. Wang Ting Song (汪廷松先生), aged 58, is a deputy general manager of the Company. He graduated from Shanghai Chemical College (上海化工學院) in 1969 majoring in Automatic Control (化工自動化). Mr. Wang was a supervisor of a workshop in a concrete plant of Hezhang county from September 1970 to February 1974. He was a technician in a printing factory of Hezhang county from March 1974 to October 1978. He joined Huadong Electronics Factory (華東電子管廠) in November 1978 as an engineer, and was promoted as the standing deputy head of the TV set factory of Huadong Electronics in November 1997. Mr. Wang was the deputy general manager of Sample Computer Technology between November 1999 and December 2000 before he joined the Company in January 2001.

Ms. Hu Hui Lin (胡慧玲女士), aged 49, is a manager of the Company's finance department. She graduated from Shenyang Engineering University (瀋陽工業大學) with a bachelor degree in 1998. She was qualified as a professional accountant in PRC in 1993. Ms. Hu was an accountant of Nanjing Tractor Repairing Factory (南京拖拉機修理總廠) (formerly known as Integrated Cold Storage Factory (組合冷庫廠)) from January 1973 to June 1991. Later, she became the head of finance department of Nanjing Wuzhou Refrigeration Equipment Group (南京五洲製冷集團) (formerly known as (Nanjing Freezer General Factory (南京冷凍機總廠)) from June 1991 to July 1997. Ms. Hu was the manager of the finance department of Nanjing Zhongbei Investment Consultation Company (南京中北投資諮詢公司) between July 1997 and June 1998 and was the manager of the finance department of Nanda Pharmaceutical Company Limited (南大藥業股份有限公司) from June 1998 to January 2000. Ms. Hu was the manager of the finance department of Sample Computer Technology, the predecessor of the Company, between January 2000 and December 2000.

Ms. Chan Wei Wei (陳慧慧女士), aged 26, is the company secretary, qualified accountant and one of the authorised representatives of the Company and is responsible for the financial and accounting management and secretarial affairs of the Company. Ms. Chan graduated from City University of Hong Kong with a degree in business administration in Accountancy in 1999 and is an associate member of the Hong Kong Society of Accountants and the Association of Chartered Certified Accountants. Before joining the Company in October 2003, she worked as an audit senior in the Hong Kong office of RSM Nelson Wheeler, an international accounting firm.

DIRECTORS, SUPERVISORS, SENIOR MANAGEMENT AND STAFF

COMPLIANCE OFFICER

Mr. Guo Ya Jun (郭亞軍先生), aged 44, an executive Director, compliance officer and one of the authorised representatives of the Company. Mr. Guo will advise and assist the Board in implementing procedures to ensure that the Company complies with the GEM Listing Rules and other relevant laws applicable to the Company. Details of the background and qualifications of Mr. Guo Ya Jun (郭亞軍) are set out in the paragraph headed “Executive Directors” under this section.

AUDIT COMMITTEE

The Company established an audit committee on 27 August 2003 with terms of reference in compliance with Rules 5.28 to 5.33 of the GEM Listing Rules. The primary duties of the audit committee are the reviewing of the financial reporting process and internal control system of the Company. The members of the Company’s audit committee are set out as follows:

Name	Position in the audit committee	Position in the board of Directors
Mr. Zhang Zhan (張展先生)	Chairman	Independent non-executive Director
Mr. Wang Wei (王煒先生)	Member	Independent non-executive Director
Mr. Lau Shek Yau John (劉石佑先生)	Member	Independent non-executive Director

EMPLOYEES

Overview

As at the Latest Practicable Date, the Company had a total of 172 employees in the PRC. An analysis of their duties is as follows:

	As at 31 December 2001	As at 31 December 2002	As at 31 December 2003	As at the Latest Practicable Date
Management and general administration	20	27	36	36
Research and development	22	37	35	35
Sales and marketing	16	40	36	36
Technical support service	28	56	65	65
	<hr/>	<hr/>	<hr/>	<hr/>
Total	86	160	172	172
	<hr/> <hr/>	<hr/> <hr/>	<hr/> <hr/>	<hr/> <hr/>

DIRECTORS, SUPERVISORS, SENIOR MANAGEMENT AND STAFF

Relationship with employees

The pay scale of the Company's employees is maintained at a competitive level and employees are rewarded based on their performance according to the general framework of the Company's salaries system, which is reviewed annually. The Company has not experienced any significant labour disputes or strikes which have led to the disruption of its normal business operations.

Retirement benefit scheme

The Company provides employee benefits covering pension insurance scheme, unemployment insurance scheme, labour injury insurance scheme and maternity insurance scheme (collectively under the social insurance scheme) for its staffs, whereby the Company is required to make monthly contributions to these schemes. The Company has no obligation for the payment of retirement and other post-retirement benefits of employees other than the monthly contributions described above. Expenses incurred by the Company in connection with the retirement benefit plans were approximately RMB16,000, RMB330,000 and RMB248,000 for each of the three years ended 31 December 2003.

As confirmed by the Company's legal adviser as to PRC law, the Company has complied with the relevant regulations and provisions under PRC law in respect of the management of the social insurance scheme.

Other benefits

The Company also maintains a medical insurance scheme for its staff. The medical insurance scheme covers four areas namely (i) group personal accident plan; (ii) group crisis insurance; (iii) group medical out-patient insurance; and (iv) group medical in-patient insurance.

SUBSTANTIAL SHAREHOLDERS AND INITIAL MANAGEMENT SHAREHOLDERS

SUBSTANTIAL SHAREHOLDERS

So far as the Directors are aware, immediately after the completion of the Placing (without taking into account any Shares which may fall to be issued upon the exercise of any option granted under the Share Option Scheme), the following persons will have an interest or short position in the shares or underlying shares of the Company which would fall to be disclosed to the Company under the provisions of Divisions 2 and 3 of Part XV of the SFO, or will be directly or indirectly interested in 10% or more of the nominal value of any class of share capital carrying rights to vote in all circumstances at general meetings of the Company:

Name of Shareholder	Number of Domestic Shares	Nature of interest	Approximate percentage of registered capital immediately after the completion of the Placing (without taking into account any Shares which may fall to be issued upon the exercise of any options granted under the Share Option Scheme) (%) (Note 1)
Sample Group (Note 2)	19,650,000	Beneficial and corporate	30.47
Nanjing Zhongbei	12,000,000	Beneficial	18.60
Huadong Technology	12,000,000	Beneficial	18.60
Nanjing Huadong Electronic Group Company (南京華東電子集團公司) (Note 3)	12,000,000	Corporate	18.60

Notes:

- Unless otherwise stated, all securities are long positions held by the Shareholders.
- Sample Group directly holds 18,000,000 Domestic Shares and is also interested in 95% of the registered capital of Sample Commerce City, which in turn is directly interested in 1,650,000 Domestic Shares. Pursuant to section 316 of the SFO, Sample Group is deemed to be interested in the 1,650,000 Domestic Shares held by Sample Commerce City.
- Pursuant to section 316 of the SFO, Nanjing Huadong Electronic Group Company (南京華東電子集團公司) is deemed to be interested in 12,000,000 Domestic Shares held by Huadong Technology as Nanjing Huadong Electronic Group Company (南京華東電子集團公司) is interested in 45.20% of the registered capital of Huadong Technology as at 31 December 2003 according to the 2003 annual report of Huadong Technology.

SUBSTANTIAL SHAREHOLDERS AND INITIAL MANAGEMENT SHAREHOLDERS

INITIAL MANAGEMENT SHAREHOLDERS

The following persons are individually and/or collectively entitled to exercise, or control the exercise of, 5% or more of the voting power at any general meeting of the Company and/or are able to, as a practical matter, direct or influence the management of the Company immediately prior to the Listing Date and are therefore regarded as Initial Management Shareholders under the GEM Listing Rules:

Name of Initial Management Shareholder	Number of Domestic Shares held immediately after the completion of the Placing (without taking into account any Shares which may fall to be issued upon the exercise of any options granted under the Share Option Scheme)	Approximate percentage in the registered capital of the Company immediately after the completion of the Placing (without taking into account any Shares which may fall to be issued upon the exercise of any options granted under the Share Option Scheme)(%)
Sample Group (Note 1)	18,000,000	27.91
Nanjing Zhongbei	12,000,000	18.60
Huadong Technology	12,000,000	18.60
Sample Commerce City	1,650,000	2.56
Sha Min (沙敏) (Note 2)	450,000	0.70

Notes:

1. Sample Group is also interested in 95% of the registered capital of Sample Commerce City, which in turn will be directly interested in approximately 2.56% of the registered capital of the Company immediately after the completion of the Placing (without taking into account any Shares which may fall to be issued upon the exercise of any options granted under the Share Option Scheme).
2. Sha Min (沙敏), being a Director, is directly interested in approximately 24.42% of the registered capital of Sample Group, which in turn will be directly interested in approximately 27.91% of the registered capital of the Company immediately after the completion of the Placing (without taking into account any Shares which may fall to be issued upon the exercise of any options granted under the Share Option Scheme). Sample Group is also interested in 95% of the registered capital of Sample Commerce City, which in turn will be directly interested in approximately 2.56% of the registered capital of the Company immediately after the completion of the Placing (without taking into account any Shares which may fall to be issued upon the exercise of any options granted under the Share Option Scheme).

SUBSTANTIAL SHAREHOLDERS AND INITIAL MANAGEMENT SHAREHOLDERS

UNDERTAKINGS

Non-disposal undertakings

Each of Sample Group, Nanjing Zhongbei, Huadong Technology, Sample Commerce City and Sha Min (沙敏), being an Initial Management Shareholder, has undertaken to the Company and the Stock Exchange that, during the Lock-up Period, it/he will not, save as provided in Rule 13.18 of the GEM Listing Rules, (i) dispose of (nor enter into any agreement to dispose of) nor permit the registered holder to dispose of (or to enter into any agreement to dispose of) any of its/his interest in its/his Relevant Securities; or (ii) otherwise create (nor enter into any agreement to create) nor permit the registered holder to create (or to enter into any agreement to create) any options, rights, interests or encumbrances in respect of any such interest.

Each of the shareholders of Sample Group and Sample Commerce City has undertaken to the Company and the Stock Exchange that it/he/she will not dispose of (nor enter into any agreement to dispose of) any of its/his/her equity interest in Sample Group and Sample Commerce City respectively for a period of 12 months from the Listing Date.

Each of the Initial Management Shareholders has also undertaken to the Company and the Stock Exchange that it/he will comply with the requirements of Rule 13.19 of the GEM Listing Rules in respect of its/his Relevant Securities (including in the event of the creation of any charge or pledge over a direct or indirect interest in the Relevant Securities or the disposal of or the intention to dispose of its/his Relevant Securities pursuant to such charge or pledge, the Company must be informed immediately of such interest and the number of securities affected).

Each of the Directors (including the non-executive Directors and the independent non-executive Directors) has undertaken to the Company, the Sponsor and the Stock Exchange that he will: (i) not approve and will procure the Company not to approve: (a) the transfer of any of the Domestic Shares owned by each of the Initial Management Shareholders; and (b) the registration of any such transfer with the Nanjing Administration for Industry and Commerce (南京市工商行政管理局), during the Lock-up Period; (ii) submit copies of the undertakings in favour of the Company, the Stock Exchange and the Sponsor in relation to the restriction on disposal of the Domestic Shares given by the Initial Management Shareholders to the Nanjing Administration for Industry and Commerce (南京市工商行政管理局) for filing purpose; and (iii) to request the Nanjing Administration for Industry and Commerce (南京市工商行政管理局): (a) to insert a note in the register of the Company's information maintained by the Nanjing Administration for Industry and Commerce (南京市工商行政管理局) stating that all the Domestic Shares held by the Initial Management Shareholders cannot be transferred during the Lock-up Period; and (b) not to register any transfer of the Domestic Shares held by the Initial Management Shareholders.

Non-competition undertakings

Each of the Initial Management Shareholders and Liao Qiong (廖瓊) currently does not engage in any business that competes directly or indirectly with that of the Company. In addition, each of the Initial Management Shareholders and Liao Qiong (廖瓊) has separately undertaken to the Company that each of them will not directly or indirectly engage in any business that may compete with the business of the Company and any of the Company's subsidiaries so long as he/she/it remains as a Shareholder, an executive Director or indirect shareholder of the Company (as the case may be) pursuant to a non-competition undertaking given by each of the Initial Management Shareholders and Liao Qiong (廖瓊) on 24 April 2004.

SUBSTANTIAL SHAREHOLDERS AND INITIAL MANAGEMENT SHAREHOLDERS

RELATED PARTY TRANSACTIONS

Transactions with Nanjing Sample Computer Trading Company Limited (南京三寶計算機銷售有限公司) (“Sample Computer Trading”)

Sample Computer Trading is a limited liability company incorporated in the PRC which was owned as to approximately 57.14% by Sun Huai Dong (張懷東), approximately 28.57% by Sample Group and approximately 14.29% by Sample Commerce City. Sun Huai Dong (張懷東) is one of the shareholders of Sample Group with a 10.15% equity interest. Sample Group is a shareholder of Sample Commerce City with a 95% equity interest. Both Sample Group and Sample Commerce City are Promoters. Sample Computer Trading is taken as a related company in the accountants' report set out in Appendix I to this prospectus.

According to a capital verification report dated 28 January 2003 issued by Nanjing Tianzheng Certified Public Accountants (南京天正會計師事務所), the equity interests of Sample Computer Trading were transferred by Sun Huai Dong (張懷東), Sample Group and Sample Commerce City to two individuals and one enterprise legal person which are Independent Third Parties. After the transfer, Sun Huai Dong (張懷東), Sample Group and Sample Commerce City cease to be shareholders of Sample Computer Trading.

Sales to Sample Computer Trading (“Sample Computer Trading Sale Transactions”)

Sample Computer Trading and the Company had entered into a joint purchase contract dated 20 December 2000 pursuant to which the Company agreed to purchase production equipment required by Sample Computer Trading when the Company purchases production equipment for itself. It was agreed that the price of the production equipment provided by the Company to Sample Computer Trading should be less than the market retail price. The price to be paid by Sample Computer Trading should be the purchase price paid by the Company together with reasonable transportation costs. For each of the three years ended 31 December 2003, the sales to Sample Computer Trading amounted to approximately RMB44,000, RMB7.5 million and nil respectively, representing approximately 0.1%, 12.1% and nil respectively of the Group's total turnover during the respective years.

As a result of the transfer mentioned above and due to a material change in the business of Sample Computer Trading and in anticipation of the listing of the H Shares on GEM, the Company has ceased to conduct the Sample Computer Trading Sale Transactions since 1 January 2003. The cessation, to a small extent, has an adverse effect on the Company's turnover. As the profit margin derived from sales of production equipment was relatively low, the net profit of the Group in 2003 was not significantly affected.

Purchase from Sample Computer Trading (“Sample Computer Trading Purchase Transactions”)

The Company and Sample Computer Trading had entered into two contracts dated 30 December 2000 and 28 December 2001 respectively. Pursuant to these contracts, Sample Computer Trading should supply the Company with computers and peripherals for each of the years 2001 and 2002. It was agreed that the price of the products supplied by Sample Computer Trading should be the aggregate of the cost of the relevant products together with reasonable profits. The profit margin made by Sample Computer Trading should not be higher than the average profit margin of the market for the relevant industry. For each of the three years ended 31 December 2003, the purchase made by the Company from Sample Computer Trading amounted to approximately RMB1.7 million, RMB1.5 million and nil respectively, representing approximately 7.9%, 6.0% and nil respectively of the aggregate purchases made during the respective years. As the components required by the Company are generic in nature and there exists alternative suppliers in the market, the cost of sale of the Company will not be materially affected.

As a result of the transfer mentioned above and due to a material change in the business of Sample Computer Trading and in anticipation of the listing of the H Shares on GEM, the Company has ceased to

SUBSTANTIAL SHAREHOLDERS AND INITIAL MANAGEMENT SHAREHOLDERS

conduct the Sample Computer Trading Purchase Transactions since 1 January 2003. The Directors confirm that the Company will not enter into any transaction with Sample Computer Trading after the Listing Date.

Transaction with Shanghai Sample Computer Company Limited (上海三寶計算機有限公司) (“Shanghai Sample Computer”)

Shanghai Sample Computer is a limited liability company incorporated in the PRC which is owned as to 90% by Sample Group and as to 10% by Sample Computer Trading. Sample Group is one of the Promoters. Shanghai Sample Computer is taken as a related company in the accountants' report set out in Appendix I to this prospectus.

Shanghai Sample Computer and the Company had entered into a contract dated 23 November 2002 pursuant to which the Company had agreed to sell certain hardware to Shanghai Sample Computer at a consideration of approximately RMB258,000, representing approximately 0.4% of the Company's sales for the year ended 31 December 2002.

Such transaction was a one-off transaction and is not continuing in nature.

Transaction with Sample Group

The Company and Sample Group had entered into a shareholding transfer agreement dated 10 November 2001 pursuant to which the Company agreed to acquire a 23% equity interest in Sample Information System Engineering from Sample Group at a consideration of RMB5,060,000. The consideration was based on book value of the equity interest of Sample Information System Engineering and the Directors considered that it was fair and reasonable.

The above transaction was a one-off transaction and is not continuing in nature.

Transaction with Sample Commerce City

Sample Commerce City and the Company had entered into three lease agreements dated 30 December 2000, 30 December 2001 and 28 December 2002 respectively. Pursuant to these lease agreements, Sample Commerce City has rented a property located at the second, third and fourth floors of No. 454 Zhujiang Road to the Company from 1 January 2001 to 31 December 2003. The annual rental for each of the three years ended 31 December 2003 was RMB640,000, RMB250,000 and RMB250,000 respectively. Pursuant to a termination agreement dated 31 May 2003, the lease agreement dated 28 December 2002 has been terminated. For the five months ended 31 May 2003 before the termination of these agreements, the rental recorded by the Company amounted to RMB104,000.

Such transaction has ceased and therefore will not continue in the future.

Transaction between Sample Information System Engineering and Shanghai Sample Information Technology Company Limited (上海三寶信息技術有限公司) (“Shanghai Information Technology”)

Sample Information System Engineering is a limited liability company established in the PRC which is owned as to 80% by the Company and as to 20% by Sample Group and is therefore a subsidiary of the Company.

Shanghai Information Technology is a limited liability company established in the PRC which was owned as to 77.33% by Sample Group, as to 9% by Huo Hi Jun (霍立郡), as to 7% by Gu Qing (顧青) and as to 6.67% by Shi Zhang Lin (施正林). Shanghai Information Technology is taken as a related company in the Accountants' Report set out in Appendix I to this prospectus.

SUBSTANTIAL SHAREHOLDERS AND INITIAL MANAGEMENT SHAREHOLDERS

On 10 December 2001, Sample Information System Engineering and Shanghai Information Technology entered into a technology contract (“Technology Contract”) pursuant to which Sample Information System Engineering agreed to research and develop Remote Centralisation Recording System Software (遠程集中抄表系統軟件) for Shanghai Information Technology. This project has to be completed within three months from the date of signing of the Technology Contract. The copyright and the ownership of the technology product was transferred to Shanghai Information Technology at a consideration of RMB900,000. According to the Technology Contract, since Shanghai Information Technology has not paid any research and development fees to Sample Information System Engineering, the assets purchased during the period of research and development belong to Sample Information System Engineering.

Pursuant to a share transfer agreement entered into between Sample Group and Nanjing Puhua Technology Industry Trading Company Limited (南京浦華科工貿有限公司), an Independent Third Party, dated 12 August 2003 and as approved by a resolution passed at a general meeting of Shanghai Information Technology, Sample Group transferred all of its equity interest in Shanghai Information Technology to Nanjing Puhua Technology Industry Trading Company Limited (南京浦華科工貿有限公司) at a consideration of approximately RMB3.9 million. After the transfer, Sample Group ceases to be a shareholder of Shanghai Information Technology.

As a result of the transfer mentioned above and due to the fact that the above transaction was a one-off transaction, it will not constitute a connected transaction of the Company after the Listing Date.

Transactions with Tian Yuan Holding Company Limited (天元控股有限公司) (“Tian Yuan Holding”)

Tian Yuan Holding is a limited liability company incorporated in the PRC which was owned as to 20% by Nanjing Zhongbei, an Initial Management Shareholder and a Promotor. According to the 2003 annual report of Nanjing Zhongbei, Nanjing Zhongbei disposed of all of its equity interest in Tian Yuan Holding in December 2003. Tian Yuan Holding is taken as a related company in the accountants’ report set out in Appendix I to this prospectus.



The Company entered into a loan agreement with Shenzhen Development Bank Co., Ltd, Nanjing Branch (深圳發展銀行南京分行) on 20 August 2001 pursuant to which Shenzhen Development Bank Co., Ltd, Nanjing Branch (深圳發展銀行南京分行) agreed to lend the Company RMB20 million at a monthly interest rate of 0.4875%. The loan was guaranteed by Tian Yuan Investment Management Company Limited (天元投資管理有限公司), which according to the Directors, was the predecessor of Tian Yuan Holding. The loan had been fully settled on 4 June 2002 and the guarantee was then released on the same date.

The Company also entered into a loan agreement with Shanghai Pudong Development Bank, Nanjing Branch (上海浦東發展銀行南京分行) on 10 July 2002 pursuant to which Shanghai Pudong Development Bank, Nanjing Branch (上海浦東發展銀行南京分行) agreed to lend the Company RMB20 million at a monthly rate of 0.4425%. The loan was guaranteed by Tian Yuan Holding and had been fully settled on 29 May 2003 and that the guarantee was then released on the same date.



The above transactions have ceased and are not continuing in nature.



EXEMPTED CONTINUING CONNECTED TRANSACTIONS

Licence Agreement and Supplemental Agreement

The Company and Sample Group entered into the Licence Agreement pursuant to which Sample Group agreed to grant a licence to the Company for the use of, inter alia, the trademarks “” and “神保” at nil consideration with effect from 1 January 2001. Pursuant to the Supplemental Agreement, Sample Group irrevocably agreed to grant a licence to the Company for (i) the use of the trademark “”; and (ii) the

SUBSTANTIAL SHAREHOLDERS AND INITIAL MANAGEMENT SHAREHOLDERS

exclusive use of the trademark “神保” in connection with the services within the scope of services approved in trademark registration nos. 1223813 and 1223880 (i.e. class 42) at nil consideration. The licence period for (i) commenced on 1 January 2001 until 31 July 2008 whilst the licence period for (ii) commenced on 1 January 2001 until the earlier of (a) 31 July 2008; and (b) the date when the necessary procedures for the transfer of the trademark have been completed pursuant to the exercise of the Transfer Option under the Option Agreement. Under the Supplemental Agreement, Sample Group retains the right to use the trademark “” in connection with services included in class 42 and the Company was granted a pre-emptive right to acquire the trademarks “” and “神保” should Sample Group intend to transfer the same to third parties under the same terms and conditions after the expiry of the Supplemental Agreement.

The trademarks “” and “神保” are both registered in the name of Sample Group for a period from 14 November 1998 to 13 November 2008. Sample Group principally applied the trademark “” to its promotional brochures and letterheads and it did not use the trademark “神保” in any areas or products as at the Latest Practicable Date.

The Directors and the Sponsor are of the view that the Licence Agreement and the Supplemental Agreement are in the ordinary and usual course of business of the Company, on normal commercial terms, are fair and reasonable to the Company and in the interests of the Shareholders as a whole.

Option Agreement

The Company and Sample Group entered into an Option Agreement pursuant to which an option was granted to the Company by Sample Group exercisable from the date of the Option Agreement to 31 July 2008 (“Option Period”). During the Option Period, the Company may, by written notice, request Sample Group to transfer the trademark “神保” to the Company at nil consideration. According to the Articles of Association, the non-exercise of the Transfer Option will not be subject to approval from the independent Shareholders and/or the independent non-executive Directors. It was further agreed that save for the tax required to be paid for the transfer of the trademark “神保”, which shall be paid by the parties in accordance with PRC laws, rules and regulations, the Company is not required to bear any costs in relation to the execution of the Option Agreement, the exercise of the option thereunder and the transfer of the trademark “神保”. It is the intention of the Directors to exercise the Transfer Option upon listing of the H Shares on GEM.

The Directors and the Sponsor are of the view that the Option Agreement is in the ordinary and usual course of business of the Company on normal commercial terms, and fair and reasonable to the Company and in the interests of the Shareholders as a whole.

Each of the connected transactions set out above constitutes a continuing connected transaction of the Company under the GEM Listing Rules. The continuing connected transactions are on normal commercial terms and are *de minimis* transactions under Rule 20.33(3) of the GEM Listing Rules where each of the percentage ratios, where applicable, as defined in Rule 19.07 of the GEM Listing Rules (other than the profits ratio) on an annual basis is either (a) less than 0.1%; or (b) equal to or more than 0.1% but less than 2.5% and the annual consideration is less than HK\$1,000,000. Accordingly, the transactions are not subject to the reporting, announcement or shareholders’ approval requirements under Chapter 20 of the GEM Listing Rules.

The Directors confirm that if the Group is going to use any of the abovementioned trademarks in the future, it will comply with the connected transaction requirements under the GEM Listing Rules.

SHARE CAPITAL

The registered capital of the Company, issued or to be issued, fully paid or credited as fully-paid, immediately after the completion of the Placing (without taking into account any Shares which may fall to be issued upon the exercise of any options granted under the Share Option Scheme), will be as follows:

<i>Registered capital</i>	<i>RMB</i>
44,100,000 Domestic Shares of RMB1.00 each in issue (excluding 900,000 H Shares to be converted from Domestic Shares held by the Vendor) (<i>Notes 1 and 2</i>)	44,100,000
20,400,000 H Shares to be issued pursuant to the Placing (including 900,000 H Shares to be converted from Domestic Shares held by the Vendor)	20,400,000
<hr style="width: 100%; border: 0.5px solid black;"/>	<hr style="width: 100%; border: 0.5px solid black;"/>
<i>Total:</i>	
<u>64,500,000</u> Shares	<u>64,500,000</u>

Notes:

1. Pursuant to a shareholders' resolution dated 24 April 2004 and the approval document issued by CSRC on 26 March 2004, the Company and the Vendor are authorised to offer the H Shares for subscription and purchase under the Placing.
2. Pursuant to the Provisional Measures on the Administration of the Reduction of the State-owned Shares for Raising Public Security Funds (減持國有股募集社會保障資金管理暫行辦法) promulgated by the State Council on 12 June 2001, holders of state-owned shares of a joint stock limited company in the PRC shall offer for sale such number of state-owned shares which is equivalent to 10% of the funds to be raised under the initial public offering of the joint stock limited company. Accordingly, the 900,000 State-owned Shares originally held by Nanjing Daily were transferred to the Vendor which will be converted to 900,000 H Shares and are offered for sale at the Placing Price under the Placing. Such H Shares will rank pari passu with the New H Shares in all respect. The proceeds from the sale of the Sale H Shares will be remitted to the National Social Security Fund (全國社會保障基金). According to the PRC legal opinion, both CSRC and SASAC have no objection to the above arrangement in relation to the Domestic Shares held by the Vendor in the Company.

I. Minimum public float

In compliance with Rules 25.08 and 25.09 of the GEM Listing Rules, at the time of listing and at all times thereafter, the Company must ensure that all H Shares are held by the public (except as otherwise permitted by the Stock Exchange), the H Shares must normally constitute not less than 10% of the total issued registered share capital of the Company, and the aggregate amount of H Shares and such other securities of the Company which are held by the public must constitute not less than 25% of the total issued registered share capital of the Company. In compliance with Note 2 to Rule 11.23 of the GEM Listing Rules, no employees of the Company or its subsidiaries or an associate of such employee shall, at the time of listing be regarded as members of the public.

SHARE CAPITAL

2. Ranking

Domestic Shares and H Shares are both ordinary shares in the share capital of the Company. However, H Shares can only be subscribed for and traded in Hong Kong dollars among legal or natural persons of Hong Kong, Macau, Taiwan or any country other than the PRC. Domestic Shares, on the other hand, can only be subscribed for and traded among legal or natural persons of the PRC (other than Hong Kong, Macau and Taiwan) and must be subscribed for and traded in RMB. All dividends in respect of H Shares are to be paid by the Company in Hong Kong dollars whereas all dividends in respect of Domestic Shares are to be paid by the Company in RMB.

All Domestic Shares held by the Promoters may not be sold within a period of three years from the date of establishment of the Company and ended on 29 December 2003. As at the Latest Practicable Date, none of the Promoters had sold any Domestic Shares held by it. The Domestic Shares are not admitted for listing on any other stock exchange and no arrangement has been made for the Domestic Shares to be traded or dealt with on any other authorised trading facility in the PRC.

Except as described above and in relation to the despatch of notices and financial reports to shareholders, dispute resolution, registration of shares on different parts of the register of shareholders, the method of share transfer and the appointment of dividend receiving agents, that are all provided for in the Articles of Association and summarised in Appendix VI to this prospectus, the Domestic Shares and the H Shares will rank *pari passu* with each other in all respects and, in particular, will rank equally for all dividends or distributions declared, paid or made after the Listing Date. However, the transfer of Domestic Shares is subject to such restrictions as stipulated in the PRC law from time to time.

Save for the Placing, the Company does not propose to carry out a public or private issue or to place securities simultaneously with the Placing in the foreseeable future. The Company has not approved any share or debt issue plan other than the Placing.

FINANCIAL INFORMATION

INDEBTEDNESS

Borrowings

As at 30 April 2004, being the latest practicable date for the purpose of this statement, the Group had total outstanding unsecured bank and other borrowings of approximately RMB30.0 million.

The details of the unsecured loans are as follows:

	Amount	Interest rate	Period
	<i>RMB'000</i>		
<i>Bank loans:</i>			
1. Industrial and Commercial Bank of China	5,000 (Note 1)	0.4779% per month	20 May 2003- 14 May 2004
2. Industrial and Commercial Bank of China	5,000	0.4779% per month	31 October 2003- 28 October 2004
3. Industrial and Commercial Bank of China	5,000	0.4779% per month	14 November 2003- 4 November 2004
4. Industrial and Commercial Bank of China	15,000 (Note 2)	0.4575% per month	30 June 2003- 14 June 2006
	<u>30,000</u>		

Notes:

1. The loan was settled in full on 14 May 2004.
2. The Directors intend to settle the loan as to RMB5 million by 21 October 2005 and as to RMB10 million by 14 June 2006. The loan was guaranteed by Sample Group, a Promoter and Initial Management Shareholder of the Company, pursuant to a guarantee agreement entered into between Sample Group and ICBC on 30 June 2003. According to an undertaking issued by Industrial and Commercial Bank of China dated 29 December 2003, ICBC undertook that the guarantee provided by Sample Group would be released and substituted by guarantees in the form of the Company's credit upon the listing of the H Shares on GEM.

Disclaimer

Save as aforesaid and as otherwise disclosed in this prospectus, and apart from intra-group liabilities and normal trade payables, the Company, at the close of business on 30 April 2004, did not have any outstanding loan capital issued or agreed to be issued, bank overdrafts, loans, debt securities or other similar indebtedness, liabilities under acceptance (other than normal trade bills) or acceptance credits, debentures, mortgages, charges, finance lease or hire purchase commitments, guarantees or other material contingent liabilities.

No material changes

Save as disclosed above, the Directors confirm that there has been no material change in the indebtedness and contingent liabilities of the Company since 30 April 2004.

FINANCIAL INFORMATION

LIQUIDITY, FINANCIAL RESOURCES AND CAPITAL STRUCTURE

Net current assets

As at 30 April 2004, being the latest practicable date for the purpose of this statement, the Group had net current assets of approximately RMB56.5 million. Current assets comprised bank balances, deposits and cash of approximately RMB39.5 million, inventories of approximately RMB1.6 million, amounts due from customers for contract work of approximately RMB3.7 million, trade receivables of approximately RMB27.7 million, other receivables and prepayments to suppliers of approximately RMB14.1 million and taxation recoverable of approximately RMB1.2 million. Current liabilities of the Group comprised trade payables of approximately RMB9.2 million, other payables of approximately RMB4.4 million, taxation payable of approximately RMB2.7 million and short-term bank loans of approximately RMB15.0 million. The cash on hand is placed at PRC banks and is not subject to any charges or pledges for any loan granted to the Group.

Financial resources

The Company generally finances its operation by equity funding, internally generated cashflow and bank borrowings.

Borrowings and credit facilities

The Company generally relies on its internal cash flows, banking and other loan facilities available from its principal bankers to meet the requirements for its operations. Save for the short-term and long-term bank loan borrowings of approximately RMB30.0 million disclosed in the paragraph headed "Indebtedness" under this section, the Company had another RMB5.0 million unutilised credit facilities as at 30 April 2004.

COMMITMENTS

Operating lease commitments

At the balance sheet dates, the Group and the Company were committed to make the following future minimum lease payments in respect of land and buildings rented under non-cancellable operating leases which fall due as follows:

	At 31 December		
	2001	2002	2003
	RMB'000	RMB'000	RMB'000
THE GROUP			
Within one year	250	280	580
	<u>250</u>	<u>280</u>	<u>580</u>
THE COMPANY			
Within one year	250	280	461
	<u>250</u>	<u>280</u>	<u>461</u>

FINANCIAL INFORMATION

Capital commitments

	THE GROUP AND THE COMPANY		
	At 31 December		
	2001	2002	2003
	<i>RMB'000</i>	<i>RMB'000</i>	<i>RMB'000</i>
Capital expenditure contracted for but not provided in the financial statements in respect of the acquisition of property, plant and equipment	880	700	11,218
	<u>880</u>	<u>700</u>	<u>11,218</u>
			<i>(Note)</i>

Note: The increase in capital expenditure during the year ended 31 December 2003 was mainly attributed to the Group's engagement in relation to the construction work located at Ma Qun, Ke Ji Yuan, Qixia District of Nanjing in the PRC.

CONTINGENT LIABILITIES

	THE GROUP AND THE COMPANY		
	At 31 December		
	2001	2002	2003
	<i>RMB'000</i>	<i>RMB'000</i>	<i>RMB'000</i>
Guarantees given to banks in respect of credit facilities granted to			
– a beneficial shareholder of the Company	30,000	–	–
– a jointly controlled entity held by a shareholder of the Company	20,000	20,000	–
– a shareholder of the Company	4,000	–	–
	<u>54,000</u>	<u>20,000</u>	<u>–</u>

FOREIGN EXCHANGE RISK

For each of the three years ended 31 December 2003, none of the Company's sales was settled in foreign exchange. The Company has not experienced any material operating difficulties or adverse impact on liquidity as a result of fluctuations in currency exchange rates in the past. The Company will not use or enter into any form of hedging instruments or arrangements against risk exposures in relation to any possible exchange fluctuation in the future. The Directors do not consider that the Company is exposed to any material foreign currency exchange risk.

FINANCIAL INFORMATION

DISCLOSURE UNDER GEM LISTING RULES 17.15 TO 17.21

Under the Chapter 17.15 of the GEM Listing Rules, a disclosure obligation arises, among other situations, where the relevant advance to an entity from the issuer or any of its subsidiaries exceeds 8% of the issuer's total asset.

Advance to an entity

As set out in the accountants' report in Appendix I to this prospectus, the value of audited consolidated total asset of the Group as at 31 December 2001 was approximately RMB106.7 million. Amounts due from Shareholders were approximately RMB28.2 million as at 31 December 2001 which included an amount due from Sample Industry of RMB26.5 million. Such amount due from Sample Industry represented approximately 24.9% of the audited consolidated total asset of the Group as at 31 December 2001. Such amount due was not trade related, unsecured, interest free with no specific term therein and was arisen from certain inter-company transactions between the Company and Sample Industry. Such balance had been fully settled as at 31 December 2002.

FINANCIAL INFORMATION

TRADING RECORD

The following table summarises the Group's turnover and results for each of the three years ended 31 December 2003. The summary is prepared on the basis of preparation set out in the accountants' report, the full text of which is set out in Appendix I to this prospectus.

	Notes	Year ended 31 December		
		2001 RMB'000	2002 RMB'000	2003 RMB'000
Turnover	1	32,715	62,175	61,836
Cost of sales		(21,988)	(38,256)	(29,096)
Gross profit		10,727	23,919	32,740
Gain on disposal of technical know-how		–	4,381	–
Other operating income		4,002	4,207	7,985
Marketing and promotional expenses		(5,264)	(4,740)	(7,188)
Administrative expenses		(7,909)	(9,852)	(7,798)
Profit from operations		1,556	17,915	25,739
Gain on disposal of a subsidiary		–	–	141
Interest on bank borrowings wholly repayable within five years		(646)	(2,600)	(2,270)
Profit before taxation		910	15,315	23,610
Taxation		(790)	(2,502)	(2,751)
Profit before minority interests		120	12,813	20,859
Minority interests		(55)	(250)	(252)
Net profit for the year		<u>65</u>	<u>12,563</u>	<u>20,607</u>
Dividends	2	<u>–</u>	<u>–</u>	<u>–</u>
Earnings per share – Basic	3	<u>RMB0.14 cents</u>	<u>RMB27.92 cents</u>	<u>RMB45.79 cents</u>

FINANCIAL INFORMATION

Notes:

1.

	Year ended 31 December		
	2001	2002	2003
	<i>RMB'000</i>	<i>RMB'000</i>	<i>RMB'000</i>
Turnover comprises:			
Provision of video security system solutions	25,686	49,130	60,875
Sales of related computer products	7,029	13,045	961
	<u>32,715</u>	<u>62,175</u>	<u>61,836</u>

Gross profit is analysed as follows:

	Year ended 31 December		
	2001	2002	2003
	<i>RMB'000</i>	<i>RMB'000</i>	<i>RMB'000</i>
Provision of video security system solutions	10,126	23,202	32,441
Sales of related computer products	601	717	299
	<u>10,727</u>	<u>23,919</u>	<u>32,740</u>

Gross profit margin is analysed as follows:

	Year ended 31 December		
	2001	2002	2003
Provision of video security system solutions	39.4%	47.2%	53.3%
Sales of related computer products	8.6%	5.5%	31.1%

2. No dividends have been declared by the Company and its subsidiaries during the Track Record Period except for Sample Information System Engineering which paid a dividend of RMB1,608,000 in 2001, of which RMB691,000 was paid to its then minority owners.
3. The calculation of basic earnings per Share for each of the three years ended 31 December 2003 was based on the Group's net profit of approximately RMB65,000, RMB12.6 million and RMB20.6 million respectively.

The calculation of basic earnings per Share is based on the 45,000,000 Domestic Shares in issue during the period from 1 January 2001 to 31 December 2003.

No diluted earnings per Share are presented as the Company has no dilutive potential shares.

MANAGEMENT DISCUSSION AND ANALYSIS OF TRADING RECORD

The following paragraphs illustrate the Directors' discussion regarding the financial performance of the Group during each of the three years ended 31 December 2003.

Financial information

The turnover of the Group mainly represents the provision of video security products/system solutions, which constitutes approximately 78.5%, 79.0% and 98.4% of the total turnover of the Group for each of the three years ended 31 December 2003.

FINANCIAL INFORMATION

For the year ended 31 December 2002, the turnover of the Group was approximately RMB62.2 million, representing an increase of approximately 90.1% compared to the previous year. During the year, the Group attained two new customers, namely Traffic Police Headquarters of the Public Security Bureau of Shandong Province (山東省公安廳交通警察總隊) and the Procurement Supply Centre of the General Customs Administration of the PRC (海關總署物資裝備供應中心). Each of them contributed a turnover of RMB14.8 million and RMB6.7 million respectively in 2002. For the year ended 31 December 2003, the turnover of the Group was approximately RMB61.8 million, representing a decrease of approximately 0.5% compared to the previous year. In terms of the provision of video security system solutions, the Group recorded a turnover of approximately RMB60.9 million for the year ended 31 December 2003, representing an increase of approximately 23.9% compared to the previous year of approximately RMB49.1 million, which was attributed to the increase in average contract sum of the projects in 2003.

The cost of sales of the Company included (i) cost incurred for the provision of video security system solutions; and (ii) cost incurred for the sales of related computer products. Cost incurred for the provision of video security system solutions amounted to approximately RMB15.6 million, RMB25.9 million and RMB28.4 million respectively for each of the three years ended 31 December 2003 and cost incurred for the sales of related computer products amounted to approximately RMB6.4 million, RMB12.3 million and RMB663,000 respectively for each of the three years ended 31 December 2003.

The Group's trade receivable turnover period was approximately 179 days, 181 days and 174 days for each of the three years ended 31 December 2003. The customers of the Group are mainly government authorities and are granted credit period ranged from 90 days to 180 days. The trade receivable turnover periods for the three years were basically in line with the credit period of the Group granted to its customers. The slight increase in trade receivable turnover period from 2001 to 2002 was attributed to that the average contracted amount in 2002 was higher than in 2001 and the duration of these contracts was on average longer than that of those contracts signed in 2001. The improvement in trade receivable turnover period from 2002 to 2003 could be attributed to the strengthened credit management control of the Group and the more proactive approach adopted by the Group in collecting its receivables during 2003 aiming at shortening the turnover period.

The Group recorded other receivables of approximately RMB7.4 million as at 31 December 2003. Such other receivables comprised (i) prepaid expenses in relation to the Placing in the amount of approximately RMB3.8 million; (ii) advances to Independent Third Parties in the amount of approximately RMB1.7 million; (iii) project bidding deposits in the amount of approximately RMB0.8 million; (iv) staff advances and borrowing for business trips in the amount of approximately RMB0.8 million; and (v) rental and other prepayment in the amount of approximately RMB0.3 million. As at 30 April 2004, approximately RMB2.9 million of the other receivables had been subsequently settled. The advances made to Independent Third Parties in the amount of approximately RMB1.7 million were unsecured and interest free for the purpose of providing short-term support to its suppliers. As at 30 April 2004, approximately RMB1.6 million of these advances had been subsequently settled. The Directors consider that the Group may, on a case by case basis, provide such similar advances to its suppliers in the future.

For each of the three years ended 31 December 2003, the trade payable turnover period was approximately 48 days, 25 days and 49 days. The increase in trade payable turnover period from 2002 to 2003 was attributed to the Group's delay in settlement of payables to certain of its suppliers in order to effectively utilise the credit terms granted by its suppliers. Such utilisation of the credit terms granted to the Group further strengthened its working capital position in 2003.

FINANCIAL INFORMATION

The Group aims to maintain its inventory turnover period below 90 days after it obtained ISO 9001 in August 2002. The inventory turnover period was approximately 149 days, 16 days and 9 days for each of the three years ended 31 December 2003. The Group maintained low inventory turnover periods in 2002 and 2003 which were well below the Group's target of 90 days. This could be attributed to the Group's good inventory and purchase management which were in accordance with its production plan and to avoid technological obsolescence of inventory and lock-up of working capital in inventory.

Amounts due from Shareholders were approximately RMB28.2 million as at 31 December 2001, which comprised amounts due from Sample Commerce City (RMB1.7 million) and Sample Industry (RMB26.5 million). Such amounts due from Shareholders were not trade related and were unsecured, interest free with no specific term therein. The amounts due from Shareholders as at 31 December 2001 represented the net balance arising from certain inter-company transactions between the Company and its Shareholders. Such balance had been fully settled as at 31 December 2002.

Gross profit margin

For each of the three years ended 31 December 2003, the gross profit margin were approximately 32.8%, 38.5% and 52.9%. The increase of the gross profit margin from 2002 to 2003 was attributed to the decrease in cost of sales from approximately RMB38.3 million for the year ended 31 December 2002 to approximately RMB29.1 million for the year ended 31 December 2003, which represented a reduction of approximately 23.9%. The drop in cost of sales was mainly due to: (i) the tightened inventory control which minimised excessive purchase of raw materials; and (ii) enhanced production efficiency which expedited the assembling and installation process of projects. In addition, the improvement in gross profit margin from 2002 to 2003 was attributed to the enhancement of gross profit ratio of certain projects of the Group as a result of increase in selling prices. Such customers included the Traffic Police Headquarters of the Public Security Bureau of Shandong Province (山東省公安廳交通警察總隊) and the Procurement and Supply Centre of the General Customs Administration of the PRC (海關總署物資裝備供應中心), which together accounted for approximately 21.1% of total turnover of the Group for the year 31 December 2003.

Gain on disposal of technical know-how

In December 2002, the Group disposed of the Procuratorate Evidence Displaying System (檢察院示證系統) and the Urban Elevator Monitoring and Testing Alarm System (城市電梯監測報警系統), with net book values of approximately RMB2.4 million and RMB1.0 million respectively, to an Independent Third Party at considerations of approximately RMB5.8 million and RMB2.5 million respectively. Such disposals resulted in a gain of approximately RMB4.4 million after tax. The Group made such disposals because the Group intended to concentrate its resources and efforts on the traffic monitoring and control sector and the customs logistics monitoring sector which have higher profit margins than the two system solutions that were disposed of.

Marketing and promotional expenses

The marketing and promotional expenses of the Group were approximately RMB5.3 million for the year ended 31 December 2001 and increased from approximately RMB4.7 million for the year ended 31 December 2002 to approximately RMB7.2 million for the year ended 31 December 2003, representing an increase of approximately 51.6%. Such increase was mainly attributed to the Group's efforts in expanding its marketing and distribution network to explore new clientele in various provinces in the PRC. The decrease of marketing and promotional expenses from 2001 to 2002 was attributed to the tightened control exerted by the Group over its marketing related expenses.

FINANCIAL INFORMATION

Administrative expenses

Administrative expenses in 2002 was approximately RMB9.9 million, representing an increase of approximately 24.6% as compared with approximately RMB7.9 million in 2001. Such increase was mainly attributable to the increase in staff costs (from approximately RMB1.4 million to approximately RMB3.3 million).

Administrative expenses dropped by 20.8% from approximately RMB9.9 million for 2002 to RMB7.8 million for 2003. The decrease in administrative expenses was attributed to a decrease in amortisation of intangible assets by approximately RMB1.7 million which resulted from the disposal of the technical know-how of RMB8.3 million in 2002.

Other operating income

Other operating income comprises mainly (i) project consultancy fee; (ii) value added tax refunded from the PRC government; and (iii) interest income. Other operating income increased by approximately 5.1% from approximately RMB4.0 million in 2001 to approximately RMB4.2 million in 2002 and increased by 89.8% from approximately RMB4.2 million for the year ended 31 December 2002 to approximately RMB8.0 million for the year ended 31 December 2003. Such increase was attributed to the increase in project consultancy fee received by the Group from approximately RMB3.1 million in 2002 to approximately RMB4.2 million in 2003.

The increase in other operating income was also attributed to a receipt of government grants for the year ended 31 December 2003. For the year ended 31 December 2003, the aggregate amount government grants received by the Group was approximately RMB4.2 million. Approximately RMB2.2 million of such government grants had been fully offset against the R&D expenses incurred by the Group while the balance in excess of the related expenses of approximately RMB2.0 million had been credited as other operating income of the Group for the year ended 31 December 2003.

Such treatment is in accordance with the accounting principles generally accepted in Hong Kong being adopted by the Company.

Net profits

The net profits of the Group for each of the three years ended 31 December 2003 were approximately RMB65,000, RMB12.6 million and RMB20.6 million respectively. The increase in net profit for 2003 was mainly due to the fact that the Company is able to acquire more contracts and its ability to control its cost more effectively.

TAXATION

Since the Company's operations are based in the PRC, the Company is only subject to PRC corporate income taxes, for the Track Record Period.

FINANCIAL INFORMATION

Pursuant to the Notice of Preferential Policy in Relation to Enterprise Income Tax (《關於企業所得稅若干優惠政策的通知》(94)財稅字第001號) jointly issued by MOF and the State Administration of Taxation (國家稅務總局), enterprises registered within the high and new technology industry development zones approved by the State Council may enjoy reduced 15% income tax rate if they are recognised and authorised as High and New Technology Enterprises (高新技術企業). The Company with the registered office in the Nanjing High and New Technology Industry Development Zone (南京高新技術產業開發區) (Note 1) has been recognised as and was conferred with the title of High and New Technology Enterprise (高新技術企業) by the Jiangsu Science and Technology Department (江蘇省科學技術廳) (Note 2). The PRC legal advisers to the Company confirmed that the Company is entitled to a preferential tax rate of 15%.

Since the amounts of certain non-deductible expenses and non-taxable income varied during the Track Record Period, and the Company and its subsidiaries were subject to different income tax rate, the effective tax rate of the Group was different from the preferential tax rate of 15%. For each of the three years ended 31 December 2003, the effective tax rate of the Group was 86.8%, 16.3% and 11.6% respectively. The decrease in effective tax rate of the Group from 2002 to 2003 was mainly attributed to the increase in profit before taxation of Golden Dragon Software, one of the subsidiaries of the Company. The profits before taxation of Golden Dragon Software for each of the two years ended 31 December 2003 were approximately RMB2.3 million and RMB5.4 million respectively. As Golden Dragon Software was exempted from PRC income tax for the two years ended 31 December 2003, the increase in profit before taxation of Golden Dragon Software in 2003 contributed to a decrease in effective tax rate of the Group. Details of the tax reconciliation are set out in note 5 of section F to the accountants' report in Appendix I to this prospectus.

Notes:

1. Nanjing High and New Technology Industry Development Zone (南京高新技術產業開發區) is one of the 21 national high and new technology industry development zones approved by the State Council pursuant to Notice of Approving National High-tech Development Zones and Related Policy No. (1999)12 Administrative File (國發(1999)12號《關於批准國家高新技術產業開發區和有關政策規定的通知》) .
2. Pursuant to High and New Technology Enterprise of National High-tech Development Zone Authorisation and Method No. (2000)324 Administrative File (國科發火字(2000)324號《國家高新技術產業開發區高新技術企業認定條件和辦法》) issued by the Ministry of Science and Technology of the PRC (中華人民共和國科學技術部), the authorisation of the said enterprises should be processed by the science and technology bodies of provinces, autonomous regions, special municipalities under the direct control of the central government, or municipalities listed on the central government planning agenda and the certificates of high-tech enterprises should be granted by the said government bodies. The Company currently holds the High and New Technology Enterprise Recognition Certificate (高新技術企業認定證書) issued by the Jiangsu Science and Technology Department (江蘇省科學技術廳) on 31 December 2002, which is valid for two years.

VAT AND BUSINESS TAX

Pursuant to the Notice of Taxation Policy in Relation to the Encouragement of Development of Software and Integrated Circuit Industries (《關於鼓勵軟體產業和集成電路產業發展有關稅收政策問題的通知》財稅(2000)25號) jointly issued by the MOF, the State Administration of Taxation (國家稅務總局), and the General Customs Administration of the PRC (中華人民共和國海關總署), statutory tax at a rate of 17% is imposed on sales of self-developed software products. Since the Group also incurs VAT to its suppliers when it makes purchases of raw material or hardware, payments of the VAT to its suppliers can be served as VAT tax credits which can be deducted from the VAT payable that the Group is subject to pay. From 24 June 2000 to 31 December 2010, the value-added tax paid (after credit) that exceeds 3% of the sales payment is immediately refunded.

FINANCIAL INFORMATION

According to the Notice on the Qualification Recognition to Tax Benefit (《稅收優惠資格認定結果通知書》(寧國稅高)國稅惠認字[2004]第5號) issued by the High-tech Bureau of the State Administration of Taxation of Nanjing (南京市國家稅務區高新技術產業開發區分區) on 30 March 2004, the software products developed by the Group namely Highway Vehicle Monitoring and Recording System V1.0 (公路車輛監測與記錄系統V1.0) and Customs Checkpoint Automatic Inspection System V1.0 (海關關口自動查驗系統V1.0) are entitled to enjoy the preferential refunding policy. According to the Notice of Eligibility for Enjoying Immediate Refunding Policy regarding (Software/Integrated Circuit) Product VAT (《享受(軟體/集成電路)產品增值稅「即徵即退」優惠政策資格通知書》棲國稅核准字(2004)003號) issued by the Qixia Branch of the Nanjing Municipal State Administration of Taxation (南京市國家稅務局栖霞分局), the software products developed by the Group namely Golden Dragon Highway Vehicle Monitoring and Data Management Software V1.0 (金龍公路車輛監測數據管理軟件V1.0), Golden Dragon Customs Checkpoint Monitoring Software V1.0 (金龍海關關口監控軟件V1.0), Golden Dragon Multi-media Display Software V1.0 (金龍多媒體展示軟件V1.0), Golden Dragon Prosecution Business Management Software V1.0 (金龍起訴業務管理軟件V1.0), Golden Dragon Justice Monitoring Management Software V1.0 (金龍司法監控管理軟件V1.0), Golden Dragon Highway Vehicles Law-violation Monitoring Software V1.0 (金龍公路車輛違章監測軟件V1.0) and Golden Dragon Law-violation Vehicle Penalty Management Software V1.0 (金龍違章車輛處罰管理軟件V1.0) are entitled to enjoy the preferential refunding policy for the period up to 31 December 2004.

Different from the PRC corporate income tax, VAT is an indirect tax borne by the customers of the Group and the Group charges the VAT on top of the saleable amounts to its customers and will pay such tax to the relevant authority on behalf of its customers. For each of the three years ended 31 December 2003, the Group was subject to VAT at a rate of 17% and the Group paid VAT in the amount of approximately RMB968,000, RMB5.1 million and RMB6.1 million. There is no VAT refund for the year ended 31 December 2001 and approximately RMB966,000 and RMB1.4 million respectively had been refunded to the Group under the aforesaid VAT refunding policy for each of the two years ended 31 December 2003.

Business tax is charged based on the gross revenues of economic activities of corporations or individuals including construction, transportation, finance and insurance or proceeds from transfer of intangible assets. Business tax is charged at different rates for different types of activities that the Group is engaged. The Group is subject to a business tax rate of 3% for transportation sector of business and a business tax rate of 5% for transfer of intangible assets. Pursuant to the Notice of Taxation regarding Implementation of the State Council's Decision on Promoting Technical Innovation, High-Tech Development and High-Tech Product Commercialisation (《關於貫徹落實「中共中央國務院關於加強技術創新，發展高科技，實現產業化的決定」有關稅發問題的通知》財稅(1999)273號) jointly issued by the MOF and State Administration of Taxation (國家稅務總局), business tax arising from the income of companies and individual persons yielded from technical transfer, technology development, technical consultation and service should be exempted. The Group's income, which were subject to 5% business tax rate, in relation to technical transfer in 2002 had been exempted as a result of the authorisation by Nanjing Technical Market Management Office (南京技術市場管理辦公室) and the approval documents (寧地稅高新減(營)字(03)第39號) and (寧地稅玄減(營)字(03)第7號) given by the High-Tech Inspection Bureau of Nanjing Local Tax Bureau (南京市地方稅務局高新分局) and the Xuan Wu Bureau of Nanjing Local Tax Bureau (南京市地方稅務局玄武分局) to the Company and Sample System Information Engineering respectively. The business tax arising from the activities covered by technical contracts signed by the Company in 2003 may be exempted after the said technical contracts were authorised and noted by Nanjing Technical Market Management Office (南京技術市場管理辦公室) and approved by Nanjing's local tax bureau (南京市地方稅務局).

FINANCIAL INFORMATION

For each of the three years ended 31 December 2003, the Group was subject to business tax at a rate of 3% or 5% and paid business tax in the amount of approximately RMB218,000, RMB171,000 and RMB801,000 respectively. Approximately RMB194,000, RMB582,000 of the business tax for each of the two years ended 31 December 2002 had been refunded to the Group under the exemption policy. The effective business tax rates for 2001, 2002 and 2003 were 3.6%, 3% and 5% respectively. As at the Latest Practicable Date, approval for business tax exemption had not been obtained and no refund of business tax for the year ended 31 December 2003 had been received by the Group. It is the intention of the Directors to apply for the annual business tax exemption for the year ending 31 December 2004 and onwards. In this regard, the business tax arising from the activities covered by the technical contracts in the relevant year may be exempted upon authorisation by Nanjing Technical Market Management Office and approval by Nanjing local tax bureau.

PROPERTY INTERESTS

Property interests held and occupied by the Group in the PRC

A parcel of land located at Ke Ji Yuan, Qixia District, Nanjing City, Jiangsu Province, the PRC was acquired by the Company from the Nanjing Land Resources Bureau (南京市國土資源局) in August 2003 with a total site area of approximately 50,117 sq.m. at a consideration of approximately RMB6.0 million. The land use rights of the property were granted to the Company for a term expiring on 17 August 2053.

The Group intends to develop the Technology Park on the parcel of land and the headquarters of the Group will also be relocated to the Technology Park. The current construction comprises a software R&D building, a main office building and a residential and catering building and will have a total gross floor area of approximately 13,814 sq.m.. The Directors anticipate that the construction will be completed in or around June 2004 with an expected total construction cost of approximately RMB49.0 million. The Directors consider that, given the Group's net cash position as at 31 December 2003, the construction costs could be financed by the Group's internal resources and the Directors do not intend to finance the construction costs by any of the proceeds from the Placing of the New H Shares. As at the Latest Practicable Date, the Group had contracted an amount of approximately RMB28.3 million for the construction, out of which approximately RMB28.2 million had been incurred and paid by the Group as at 30 April 2004. The remainder of approximately RMB0.1 million represented the capital commitment of the Group which was contracted but not provided for in the Group's financial statements as at 30 April 2004 mainly comprised fees for the initial site inspection and design, administration fees and costs for the construction of buildings, offices and other infrastructure. The expected remaining construction cost to be incurred in the amount of approximately RMB20.7 million will be applied to the construction of infrastructure, setting up plumbing and electricity systems, installation of equipment, interior and exterior design of buildings and other miscellaneous site projects.

Upon completion of the construction of the Technology Park, the Group will be subject to a property registration fee (房產登記費) of RMB4,000 and a property floor area survey charge (房屋面積勘測費) of RMB3.5 per sq.m. of the property's gross floor area.

The Group owns a property located at Gao Xin Area, Pu Kou District, Nanjing City, Jiangsu Province, the PRC. The property comprises a 2-storey house with basement and has a total gross area of approximately 395.49 sq.m. The property is currently used as the Group's office.

FINANCIAL INFORMATION

Property interests rented and occupied by the Group in the PRC

The Group has rented properties located at Rooms 701-3, 702-1, 702-2 and 702-3, Level 7, Block No. 54, Cheng Chang Development Zone, Jiangsu Software Park, No. 168 Longpan Zhong Road, Nanjing City, Jiangsu Province, the PRC which are used for software development of the Group. The properties comprise certain portion of the 7th level of a 10-storey building completed in 2000. The properties have a total gross floor area of approximately 1,658 sq.m.. Rooms 702-1, 702-2 and 702-3 are rented for terms up to 14 November 2004 at a half yearly rent of RMB283,152 and management fee of RMB33,312 whilst Room 701-3 is rented for a term up to 31 May 2004 at the rent of RMB41,310 and management fee of RMB4,860. The tenancy of Room 701-3 has been renewed under a revised tenancy agreement for a term of six months commencing from 1 June 2004 to 31 December 2004 at a semi-annual rent of RMB55,080 and management fee of RMB6,480. The properties are currently used as the headquarters of the Group and the Directors anticipate that software development operation of the Group will be relocated to the Technology Park once the construction work is completed in or around June 2004.

Property valuation

The property interests of the Group have been valued at an aggregate amount of RMB17.0 million as at 30 April 2004 by Vigers Appraisal & Consulting Limited, an independent property valuer. The text of the letter, with a summary of values and valuation certificates of these property interests, prepared by Vigers Appraisal & Consulting Limited are set out in Appendix III to this prospectus.

DIVIDEND POLICY

The Directors presently do not intend to recommend the payment of any dividend by the Group in respect of the financial year ending 31 December 2004. The declaration and payment of future dividends will be at the discretion of the Board subject to the approval of the Shareholders at its annual general meetings and will depend upon, among other things, the Group's operations, capital requirements and surplus, general financial condition, contractual restrictions and such factors as the Board may deem relevant. The Directors expect that, in future, the interim and final dividends, if any, will be paid in October and May respectively of each year. The Board will declare dividend, if any, in RMB, with respect to the H Shares on a per Share basis and will pay dividend in Hong Kong dollars. If the Company does not have sufficient foreign exchange reserves to pay its Hong Kong dollars dividends, it intends to exchange the required Hong Kong dollars from authorised banks in PRC or through other means.

DISTRIBUTABLE RESERVES

Pursuant to the relevant requirements under the Company Law, the Mandatory Provisions and related regulations, profit available for distribution to shareholders shall be the lower of the accumulated distributable profits determined in accordance with PRC accounting standards and regulations as stated in the PRC statutory accounts and the accumulated distributable profits adjusted in accordance with the accounting principles generally accepted in Hong Kong. The Company's reserve available for distribution as at 31 December 2002 and 31 December 2003 were approximately RMB7.4 million and RMB19.0 million respectively. The Company did not have any distributable reserve as at 31 December 2001.

FINANCIAL INFORMATION

STATUTORY RESERVES

Statutory surplus reserve

The Company is required to set aside 10% of its profit after taxation prepared in accordance with PRC accounting regulations to the statutory surplus reserve until the balance reaches 50% of the paid up capital or registered capital, where further appropriation will be at the directors' recommendation. Such reserve can be used to reduce any losses incurred, increase share capital or expand production operation.

Statutory public welfare reserve

The Company is required to transfer 5% to 10% of its profit after taxation prepared in accordance with PRC accounting regulations to the statutory public welfare reserve. The use of this reserve is restricted to capital expenditure for staff collective welfare facilities which are owned by the Company. The statutory public welfare reserve is not available for distribution to the shareholders (except upon liquidation of the Company). Once the capital expenditure on staff welfare facilities has been made, an equivalent amount must be transferred from the statutory public welfare reserve to a discretionary surplus reserve.

WORKING CAPITAL

The Directors are of the opinion that, taking into account the internally generated resources of the Group, existing banking facilities available, and the estimated net proceeds from the issue of H Shares under the Placing and in the absence of unforeseeable circumstances, the Group has sufficient working capital for its present requirements.

PRO FORMA ADJUSTED NET TANGIBLE ASSETS

The following is an illustrative statement of pro forma adjusted net tangible assets of the Group which has been prepared in accordance with Rule 7.31 of the GEM Listing Rules for the purpose of illustrating the effect of the Placing to the net tangible assets of the Group as if the Placing had been taken place on 31 December 2003 and based on the audited consolidated net tangible assets of the Group as at 31 December 2003 as shown in the accountants' report, the text of which is set out in Appendix I to this prospectus, and adjusted as follows:

	Audited consolidated net tangible assets of the Group as at 31 December 2003	Estimated net proceeds from the Placing of the New H Shares	Adjusted net tangible assets	Adjusted net tangible assets value per Share
	<i>RMB'000</i> <i>(Note 1)</i>	<i>RMB'000</i> <i>(Note 2)</i>	<i>RMB'000</i>	<i>(Note 3)</i>
Based on the Placing Price of HK\$2.70 per H Share	<u>72,786</u>	<u>43,960</u>	<u>116,746</u>	RMB1.81 (approximately HK\$1.71)
Based on the Placing Price of HK\$4.60 per H Share	<u>72,786</u>	<u>81,568</u>	<u>154,354</u>	RMB2.39 (approximately HK\$2.25)

FINANCIAL INFORMATION

This statement has been prepared for illustrative purposes only and because of its nature, it may not give a true picture of the financial position of the Group after the completion of the Placing. The text of the letter from the reporting accountants of the Company in respect of the pro forma adjusted net tangible assets of the Group as shown above is set out in Appendix II to this prospectus.

Notes:

1. Such information is based on the audited consolidated balance sheet of the Group as at 31 December 2003 as shown in the accountants' report, the text of which is set out in Appendix I to this prospectus.
2. The estimated net proceeds from the Placing of the New H Shares are derived after deducting related listing expenses and underwriting commission payable by the Company.
3. The adjusted net tangible asset value per Share is arrived at based on 64,500,000 Shares in issue immediately following the completion of the Placing (without taking into account any Shares which may fall to be issued upon the exercise of any options granted under the Share Option Scheme).
4. The surplus arising from the revaluation of the Group's land and buildings as at 30 April 2004 as detailed in the valuation report in Appendix III to this prospectus amounted to approximately RMB10.1 million will not be incorporated in the financial statements of the Group for the year ending 31 December 2004. If the surplus would be incorporated in the Group's financial statements for the year ending 31 December 2004, the annual depreciation charge of the Group would increase by no more than RMB208,000.

NO MATERIAL ADVERSE CHANGE

The Directors confirm that there has been no material adverse change in the financial or trading position of the Company since 31 December 2003 (being the date to which the latest audited financial statements of the Company were made up).

UNDERWRITING

PLACING UNDERWRITERS

Core Pacific – Yamaichi International (H.K.) Limited
Crosby Limited
First Shanghai Securities Limited
Asian Capital (Corporate Finance) Limited
CSC Securities (HK) Limited
First Asia Finance Group Limited
Grand Vinco Capital Limited
Taiwan Securities (HK) Co., Ltd.
TIS Securities (HK) Limited

UNDERWRITING ARRANGEMENTS AND EXPENSES

Placing and Underwriting Agreement

Pursuant to the Placing and Underwriting Agreement, the Company is offering 19,500,000 New H Shares for subscription and the Vendor is offering 900,000 Sale H Shares for sale subject to the terms and conditions thereof, the principal terms and conditions of which are set out in this prospectus.

Subject to the GEM Listing Committee granting the listing of, and permission to deal in, the H Shares to be issued and sold (including the H Shares which may be issued upon the exercise of any options which may be granted under the Share Option Scheme) as mentioned herein and to certain other conditions set out in the Placing and Underwriting Agreement, the Placing Underwriters have severally agreed to subscribe for or procure places to subscribe for the Placing Shares in accordance with the terms and conditions of the Placing and Underwriting Agreement.

Grounds for termination

The Placing Underwriters are entitled to terminate their obligations under the Placing and Underwriting Agreement upon occurrence of the following events prior to 6:00 a.m. (Hong Kong time) on the Listing Date (which is expected to be on 9 June 2004):

- (i) if it has come to the notice of CPY International:
 - (a) that any statement, considered by CPY International in its sole and absolute opinion (on behalf of the Placing Underwriters) to be material, contained in this prospectus was when this prospectus was issued, or has become, untrue, incorrect or misleading in any material respect; or
 - (b) that any matter relating to the Company has arisen or has been discovered which would, had it arisen or been discovered immediately before the date of this prospectus, constitute an omission therefrom considered by CPY International in its sole and absolute opinion (on behalf of the Placing Underwriters) to be material; or

UNDERWRITING

- (c) any breach of representations, warranties and undertakings given by the Company, the executive Directors and the Initial Management Shareholders considered by CPY International in its sole and absolute opinion (on behalf of the Placing Underwriters) to be material; or
- (d) any event, act or omission which gives or is likely to give rise to any material liability of the Company, the executive Directors or the Initial Management Shareholders pursuant to the indemnities referred to in the Placing and Underwriting Agreement; or
- (e) any material breach of any of the obligations imposed upon any party to the Placing and Underwriting Agreement (other than on any of the Placing Underwriters or CPY); or
- (f) any adverse change in the business or in the financial or trading position of the Company which is in the sole and absolute opinion of CPY International (on behalf of the Placing Underwriters) to be material in the context of the Placing; or

If there develops, occurs or comes into effect:

- (a) any event, or series of events, beyond the reasonable control of the Placing Underwriters (including, without limitation, acts of government, strikes, lock-outs, fire, explosion, flooding, civil commotion, riot, public disorder, outbreak of epidemic (including but not limited to SARS), acts of war or terrorism, acts of God, accident or interruption or delay in transportation); or
- (b) any change in local, national, international, financial, economic, political, military, industrial, fiscal, regulatory or market conditions and the imposition of any moratorium, suspension or material restriction on trading in securities generally on GEM and/or the occurrence of any disasters; or
- (c) any new law or regulation or change in existing laws or regulations or any change in the interpretation or application thereof by any court or other competent authority in the PRC, Hong Kong or any other jurisdictions relevant to the Company; or
- (d) the imposition of economic sanctions, in whatever form, directly or indirectly, by, the United States or the European Union (or any member thereof) on the PRC; or
- (e) a change or development occurs involving a prospective change in taxation or exchange control (or the implementation of any exchange control) in the PRC, Hong Kong or any other jurisdictions relevant to the Company; or
- (f) any litigation or claim of material importance of any third party being threatened or instigated against the Company; or
- (g) any change in the system under which the value of the Hong Kong currency is linked to that of the United States,

which will or may, in the sole and absolute opinion of CPY International (on behalf of the Placing Underwriters), be materially adverse to or materially affect the Placing or the success thereof or which makes it inadvisable or inexpedient to proceed with the Placing.

UNDERWRITING

Undertakings

The Initial Management Shareholders have given certain non-disposal undertakings, details of which are described under the section headed "Substantial Shareholders and Initial Management Shareholders" in this prospectus.

Commission and expenses

The Placing Underwriters will receive underwriting commission of 3.5% (if the amount of Gross Proceeds from the Placing are less than HK\$60,000,000) or 3.8% (if the amount of Gross Proceeds from the Placing are equal to or more than HK\$60,000,000) of the Placing Price of the Placing Shares.

CPY will receive a financial advisory and documentation fee relating to the Placing. The placing and underwriting commission, documentation fee, GEM listing fees, SFC transaction levy, Stock Exchange trading fee, investor compensation levy, legal and other professional fees, printing and other expenses relating to the Placing, which are currently estimated to be approximately HK\$11.7 million in aggregate based on the Placing Price of HK\$2.70 (being the lower limit of the stated price range), which are 95.6% payable by the Company and 4.4% payable by the Vendor.

Sponsor's and Placing Underwriters' interests in the Company

A sponsor agreement dated 2 June 2004 was entered into between CPY and the Company, whereby the Company has appointed CPY to act as its sponsor for the purposes of the GEM Listing Rules from the Listing Date to 31 December 2004 and the two financial years ending 31 December 2006, pursuant to which CPY will receive a sponsor fee.

Save for (i) the obligations of CPY and the Placing Underwriters under the Placing and Underwriting Agreement; (ii) the financial advisory and documentation fee payable to CPY as sponsor of the Placing; and (iii) CPY's interest under the sponsor agreement between CPY and the Company dated 2 June 2004 whereby CPY will be retained as sponsor of the Company commencing from the Listing Date to 31 December 2006, none of CPY and the Placing Underwriters has any shareholding interest in the Company or has any right or option (whether legally enforceable or not) to subscribe for or nominate persons to subscribe for any shares in the Company or has any interest in the Placing.

Save as provided for under the Placing and Underwriting Agreement, none of CPY, the Placing Underwriters and any of their respective associates has or may have, as a result of the Placing, any interest in any class of securities of the Company (including options or rights to subscribe for such securities).

None of CPY, the Placing Underwriters and any of their respective associates has accrued any material benefit as a result of the successful outcome of the Placing, including by way of example, the repayment of material outstanding indebtedness or any fee payment save and except for the underwriting commission to be received by CPY International (being the Lead Manager and a Placing Underwriter) and the other Placing Underwriters and the financial advisory and documentation fee to be received by CPY pursuant to the Placing and Underwriting Agreement.

No director or employee of CPY who is involved in providing advice to the Company has or may have, as a result of the Placing, any interest in any class of securities of the Company (including options or rights to subscribe for such securities).

No director or employee of CPY nor any of its associates has a directorship in the Company.

STRUCTURE AND CONDITIONS OF THE PLACING

DETERMINING THE PLACING PRICE

The Placing Price is expected to be fixed on or before 3 June 2004 by agreement between CPY International (on behalf of the Placing Underwriters) and the Company (for itself and on behalf of the Vendor) with reference to market demand for the Placing Shares, which will not be more than HK\$4.60 per Placing Share and will not be less than HK\$2.70 per Placing Share.

If CPY International (on behalf of the Placing Underwriters) and the Company (for itself and on behalf of the Vendor) are unable to reach an agreement on the Placing Price on the Price Determination Date, which is expected to be on or before 3 June 2004, the Placing will not proceed. In such circumstances, an announcement will be issued and published on the GEM website by the Company.

THE PLACING PRICE PAYABLE ON SUBSCRIPTION

Investors have to pay the Placing Price plus 1% brokerage, 0.005% Stock Exchange trading fee, 0.005% SFC transaction levy and 0.002% investor compensation levy. If the final Placing Price is determined at the lower limit of the indicative Placing Price range of HK\$2.70 per Placing Share, the total amount payable by the investors will be HK\$2,727.32 per board lot of 1,000 H Shares. If the final Placing Price is determined at the upper limit of the indicative Placing Price range of HK\$4.60 per Placing Share, the total amount payable by the investors will be HK\$4,646.55 per board lot of 1,000 H Shares.

PLACING

The Company and the Vendor are offering 20,400,000 H Shares in aggregate for subscription pursuant to the Placing. The Placing is fully underwritten by the Placing Underwriters, subject to the terms and conditions of the Placing and Underwriting Agreement.

Pursuant to the Placing, the Placing Underwriters shall place the 20,400,000 Placing Shares at the Placing Price (plus 1% brokerage, 0.005% Stock Exchange trading fee, 0.005% SFC transaction levy and 0.002% investor compensation levy) payable by the subscribers of the Placing Shares. The Placing Shares will be placed to selected professional and institutional investors and other investors anticipated to have sizeable demands for the Placing Shares in Hong Kong. Professional and/or institutional investors generally include brokers, dealers, high net worth individuals, companies (including fund managers) whose ordinary business involves dealing in shares and other securities and entities which regularly invest in shares and other securities.

All decisions concerning the allocation of H Shares to prospective placees pursuant to the Placing will be made on the basis of and by reference to a number of factors including the level and timing of demand, total size of the relevant investor's invested assets on equity assets in the relevant sector and whether or not it is expected that the relevant investor is likely to buy further, and/or hold or sell to H Shares, after the listing of the H Shares on GEM. Such allocation is intended to result in a distribution of the H Shares on a basis which would lead to the establishment of a solid shareholder base to the benefit of the Company or its shareholders as a whole and preference treatment may be affected to any prospective placees.

STRUCTURE AND CONDITIONS OF THE PLACING

No allocations will be made to nominee companies unless the name of the ultimate beneficiary is disclosed, without the prior written consent of the Stock Exchange. Details of the Placing will be published in accordance with Rules 10.12(4) and 16.16 of the GEM Listing Rules.

TRANSFER OF SALE H SHARES

Pursuant to the Provisional Measures on the Administration of the Reduction of the State-owned Shares for Raising Public Security Funds (減持國有股募集社會保障資金管理暫行辦法), the Stated-owned Shares originally held by Nanjing Daily were transferred to the Vendor, which will be converted into the Sale H Shares. The net proceeds from the sale of the Sale H Shares will then be transferred to the National Social Security Fund (全國社會保障基金).

CONDITIONS OF THE PLACING

Acceptance of applications for the Placing Shares in the Placing are conditional upon:

1. the GEM Listing Committee granting the listing of, and permission to deal in, the H Shares to be issued and sold pursuant to the Placing (including the H Shares which may be issued upon the exercise of any options which may be granted under the Share Option Scheme); and
2. the obligations of the Placing Underwriters under the Placing and Underwriting Agreement becoming unconditional (including, if relevant, as a result of the waiver of any condition(s) by CPY International on behalf of the Placing Underwriters) and the Placing and Underwriting Agreement not being terminated in accordance with its terms, in each case, on or before the dates and times specified in the Placing and Underwriting Agreement.

If such conditions have not been fulfilled or waived on or before the dates and times specified in the Placing and Underwriting Agreement, the Placing will not proceed and will lapse. Notice of the lapse of the Placing will be published by the Company on the GEM website as soon as practicable following such lapse.

In the above eventuality, any application monies will be returned to the applicants without interest.

The following is the text of a report, prepared for the purpose of incorporation in this prospectus, received from the auditors and reporting accountants of the Company, Deloitte Touche Tohmatsu, Certified Public Accountants, Hong Kong.

Deloitte.
德勤

德勤·關黃陳方會計師行
香港中環干諾道中111號
永安中心26樓

Deloitte Touche Tohmatsu
26/F Wing On Centre
111 Connaught Road Central
Hong Kong

2 June 2004

The Directors
Nanjing Sample Technology Company Limited
Core Pacific – Yamaichi Capital Limited

Dear Sirs,

We set out below our report on the financial information (the “Financial Information”) regarding 南京三寶科技股份有限公司(Nanjing Sample Technology Company Limited) (the “Company”) and its subsidiaries (hereinafter collectively referred to as the “Group”) for each of the three years ended 31 December 2003 (the “Relevant Periods”) for inclusion in the prospectus of the Company dated 2 June 2004 (the “Prospectus”).

The Company was established in the Mainland China (the “PRC”) and was approved to reorganise into a joint stock limited company on 28 December 2000.

As at the date of this report, the Company has the following subsidiaries, both of which are established in the PRC, directly held by the Company and engaged in the provision of video security system solutions and sales of related computer products:

Name of subsidiary	Date of establishment	Fully paid registered capital	Attributable equity interest of the Group
南京三寶信息系統工程有限公司 (Nanjing Sample Information System Engineering Company Limited)	11 March 2000	RMB22,000,000	80%
南京金龍軟件有限公司 (Nanjing Golden Dragon Software Company Limited)	7 November 2001	RMB6,000,000	95%

The statutory financial statements of the Company and its subsidiaries for each of the three years ended 31 December 2003 were audited by 南京永華會計師事務所有限公司 (Nanjing Yonghua Certified Public Accountants Co., Ltd.), certified public accountants registered in the PRC. These statutory financial statements

were prepared in accordance with the relevant accounting principles and financial regulations applicable to PRC enterprises. For the purpose of this report, we have, however, undertaken our own independent audits of the financial statements, prepared in accordance with accounting principles generally accepted in Hong Kong for the Relevant Periods in accordance with Statements of Auditing Standards issued by the Hong Kong Society of Accountants.

We have examined the audited financial statements or, where appropriate, management accounts (the "Underlying Financial Statements") of the companies comprising the Group for the Relevant Periods or since their respective dates of establishment in accordance with the Auditing Guideline "Prospectuses and the Reporting Accountant" as recommended by the Hong Kong Society of Accountants.

The consolidated balance sheets of the Group as at 31 December 2001, 31 December 2002 and 31 December 2003 and the consolidated results and cash flows of the Group for the Relevant Periods have been prepared from the Underlying Financial Statements.

The Underlying Financial Statements are the responsibility of the directors of those companies comprising the Group. The directors of the Company are responsible for the contents of the Prospectus in which this report is included. It is our responsibility to compile the Financial Information set out in this report from the Underlying Financial Statements, to form an independent opinion on the Financial Information and to report our opinion to you.

In our opinion, the Financial Information gives, for the purpose of this report, a true and fair view of the state of affairs of the Company and the Group as at 31 December 2001, 31 December 2002 and 31 December 2003 and of the profit and cash flows of the Group for the Relevant Periods.

A. CONSOLIDATED INCOME STATEMENTS

		Year ended		
	<i>Notes</i>	31 December		
		2001	2002	2003
		<i>RMB'000</i>	<i>RMB'000</i>	<i>RMB'000</i>
Turnover	2	32,715	62,175	61,836
Cost of sales		<u>(21,988)</u>	<u>(38,256)</u>	<u>(29,096)</u>
Gross profit		10,727	23,919	32,740
Gain on disposal of technical know-how		–	4,381	–
Other operating income		4,002	4,207	7,985
Marketing and promotional expenses		(5,264)	(4,740)	(7,188)
Administrative expenses		<u>(7,909)</u>	<u>(9,852)</u>	<u>(7,798)</u>
Profit from operations	3	1,556	17,915	25,739
Gain on disposal of a subsidiary		–	–	141
Interest on bank borrowings wholly repayable within five years		<u>(646)</u>	<u>(2,600)</u>	<u>(2,270)</u>
Profit before taxation		910	15,315	23,610
Taxation	5	<u>(790)</u>	<u>(2,502)</u>	<u>(2,751)</u>
Profit before minority interests		120	12,813	20,859
Minority interests		<u>(55)</u>	<u>(250)</u>	<u>(252)</u>
Net profit for the year		<u><u>65</u></u>	<u><u>12,563</u></u>	<u><u>20,607</u></u>
Dividends	6	<u><u>–</u></u>	<u><u>–</u></u>	<u><u>–</u></u>
Earnings per share – Basic	7	<u><u>0.14 cents</u></u>	<u><u>27.92 cents</u></u>	<u><u>45.79 cents</u></u>

B. CONSOLIDATED BALANCE SHEETS

	Notes	At 31 December		
		2001 RMB'000	2002 RMB'000	2003 RMB'000
Non-current assets				
Property, plant and equipment	8	1,920	2,570	21,930
Technical know-how	10	9,663	3,083	1,633
Goodwill	11	–	541	406
Deposits made on acquisition of property, plant and equipment	12	–	8,920	–
Deferred tax assets	13	1,079	858	770
		<u>12,662</u>	<u>15,972</u>	<u>24,739</u>
Current assets				
Inventories		13,317	2,731	1,566
Amounts due from customers for contract work	14	1,217	3,670	2,629
Trade and other receivables	15	17,376	48,842	40,293
Amounts due from related parties	16	28,574	196	–
Taxation recoverable		382	306	1,237
Restricted bank deposits		5,361	1,246	1,205
Bank balances and cash		27,843	36,583	64,374
		<u>94,070</u>	<u>93,574</u>	<u>111,304</u>
Current liabilities				
Trade and other payables	17	9,902	10,989	14,213
Amounts due to related parties	18	858	3,948	–
Taxation payable		205	1,684	2,198
Dividend payable to minority owners of a subsidiary		271	–	–
Short-term bank loans		45,000	34,000	25,000
		<u>56,236</u>	<u>50,621</u>	<u>41,411</u>
Net current assets		<u>37,834</u>	<u>42,953</u>	<u>69,893</u>
Total assets less current liabilities		50,496	58,925	94,632
Non-current liabilities				
Long-term bank loans	19	–	–	15,000
Minority interests		8,841	4,707	4,807
Net assets		<u>41,655</u>	<u>54,218</u>	<u>74,825</u>
Capital and reserves				
Share capital	20	45,000	45,000	45,000
Reserves		(3,345)	9,218	29,825
Shareholders' funds		<u>41,655</u>	<u>54,218</u>	<u>74,825</u>

C. BALANCE SHEETS

		At 31 December		
	Notes	2001	2002	2003
		RMB'000	RMB'000	RMB'000
Non-current assets				
Property, plant and equipment	8	1,048	1,912	21,572
Investments in subsidiaries	9	18,240	23,300	23,300
Technical know-how	10	5,230	50	–
Deposits made on acquisition of property, plant and equipment	12	–	8,920	–
Deferred tax assets	13	758	687	770
		<u>25,276</u>	<u>34,869</u>	<u>45,642</u>
Current assets				
Inventories		8,052	2,623	1,566
Amounts due from customers for contract work	14	907	3,670	2,629
Trade and other receivables		11,991	42,648	36,849
Amounts due from subsidiaries		3,952	90	–
Amounts due from related parties	16	18,898	221	–
Restricted bank deposits		5,361	1,246	1,205
Bank balances and cash		23,334	34,844	64,264
		<u>72,495</u>	<u>85,342</u>	<u>106,513</u>
Current liabilities				
Trade and other payables		8,563	9,469	12,739
Amounts due to subsidiaries		–	17,233	28,756
Amounts due to related parties	18	410	4,105	–
Taxation payable		205	1,605	2,014
Short-term bank loans		45,000	34,000	25,000
		<u>54,178</u>	<u>66,412</u>	<u>68,509</u>
Net current assets		<u>18,317</u>	<u>18,930</u>	<u>38,004</u>
Total assets less current liabilities		43,593	53,799	83,646
Non-current liabilities				
Long-term bank loans	19	–	–	15,000
Net assets		<u>43,593</u>	<u>53,799</u>	<u>68,646</u>
Capital and reserves				
Share capital	20	45,000	45,000	45,000
Reserves	21	(1,407)	8,799	23,646
Shareholders' funds		<u>43,593</u>	<u>53,799</u>	<u>68,646</u>

D. CONSOLIDATED STATEMENTS OF CHANGES IN EQUITY

	Share capital	Statutory surplus reserve	Statutory welfare fund	Retained profits (deficit)	Total
	<i>RMB'000</i>	<i>RMB'000</i>	<i>RMB'000</i>	<i>RMB'000</i>	<i>RMB'000</i>
At 1 January 2001	45,000	173	86	(3,669)	41,590
Net profit for the year	—	—	—	65	65
	<u>45,000</u>	<u>173</u>	<u>86</u>	<u>(3,669)</u>	<u>41,590</u>
At 31 December 2001	45,000	173	86	(3,604)	41,655
Net profit for the year	—	—	—	12,563	12,563
Transfers, net of minority interests' share	—	1,001	501	(1,502)	—
	<u>45,000</u>	<u>1,174</u>	<u>587</u>	<u>7,457</u>	<u>54,218</u>
At 31 December 2002	45,000	1,174	587	7,457	54,218
Net profit for the year	—	—	—	20,607	20,607
Transfers, net of minority interests' share	—	2,730	1,365	(4,095)	—
	<u>45,000</u>	<u>3,904</u>	<u>1,952</u>	<u>23,969</u>	<u>74,825</u>
At 31 December 2003	<u>45,000</u>	<u>3,904</u>	<u>1,952</u>	<u>23,969</u>	<u>74,825</u>

E. CONSOLIDATED CASH FLOW STATEMENTS

	Note	Year ended 31 December		
		2001	2002	2003
		RMB'000	RMB'000	RMB'000
Operating activities				
Profit before taxation		910	15,315	23,610
Adjustments for:				
Interest income		(52)	(96)	(310)
Interest expenses		646	2,600	2,270
Depreciation and amortisation of property, plant and equipment		964	757	715
Amortisation of technical know-how		3,260	3,122	1,450
Amortisation of goodwill		–	135	135
Loss on disposal of property, plant and equipment		41	–	5
Gain on disposal of technical know-how		–	(4,381)	–
Gain on disposal of a subsidiary		–	–	(141)
Allowance for bad and doubtful debts		–	503	–
Allowance for inventories		596	455	–
Write back of allowance for inventories		–	(556)	(40)
Operating cash flows before movements in working capital		6,365	17,854	27,694
(Increase) decrease in inventories		(3,784)	10,687	1,205
Decrease (increase) in amounts due from customers for contract work		1,679	(2,453)	1,041
Decrease (increase) in trade and other receivables		2,375	(31,969)	8,167
(Decrease) increase in trade and other payables		(11)	1,087	3,339
Cash from (used in) operations		6,624	(4,794)	41,446
PRC income tax paid		(801)	(726)	(3,251)
Net cash from (used in) operating activities		5,823	(5,520)	38,195
Investing activities				
Interest received		52	96	310
Purchase of property, plant and equipment		(531)	(1,407)	(12,670)
Acquisition of additional interest in a subsidiary		–	(5,060)	–
Proceeds from disposal of interest in a subsidiary (net of cash and cash equivalents disposed of)	22	–	–	537
Proceeds from disposal of technical know-how		–	7,839	–
Deposits (paid) refunded on acquisition of property, plant and equipment		–	(8,920)	1,400
(Advances made to) repayment from related parties		(14,820)	28,378	196
(Increase) decrease in restricted bank deposits		(5,361)	4,115	41
Net cash (used in) from investing activities		(20,660)	25,041	(10,186)

	Year ended		
	31 December		
	2001	2002	2003
	<i>RMB'000</i>	<i>RMB'000</i>	<i>RMB'000</i>
Financing activities			
Interest paid	(646)	(2,600)	(2,270)
Dividend paid	(695)	–	–
Dividend paid to minority owners of a subsidiary	(420)	(271)	–
Borrowings raised from (repaid to) related parties	1,518	3,090	(3,948)
New bank loans raised	45,000	64,000	45,000
Repayment of bank loans	(4,000)	(75,000)	(39,000)
	<u>40,757</u>	<u>(10,781)</u>	<u>(218)</u>
Net cash from (used in) financing activities			
Net increase in cash and cash equivalents	25,920	8,740	27,791
Cash and cash equivalents at 1 January	1,923	27,843	36,583
	<u>27,843</u>	<u>36,583</u>	<u>64,374</u>
Cash and cash equivalents at 31 December			
Analysis of the balances of cash and cash equivalents			
Bank balances and cash	<u>27,843</u>	<u>36,583</u>	<u>64,374</u>

F. NOTES TO THE FINANCIAL INFORMATION

The Group's books and records are maintained in Renminbi ("RMB"), the currency in which the majority of the Group's transactions is denominated.

I. PRINCIPAL ACCOUNTING POLICIES

The financial information has been prepared under the historical cost convention and in accordance with accounting principles generally accepted in Hong Kong. The principal accounting policies adopted are as follows:

Basis of consolidation

The consolidated financial statements incorporate the financial statements of the Company and its subsidiaries made up to 31 December each year.

The results of subsidiaries acquired or disposed of during the year are included in the consolidated income statement from the effective date of acquisition or up to the effective date of disposal, as appropriate.

All significant inter-company transactions and balances within the Group are eliminated on consolidation.

Goodwill

Goodwill arising on consolidation represents the excess of the cost of acquisition over the Group's interest in the fair value of the identifiable assets and liabilities of a subsidiary at the date of acquisition. Goodwill arising on acquisition is capitalised and amortised on a straight line basis over its useful economic life of five years.

On disposal of a subsidiary, the attributable amount of unamortised goodwill is included in the determination of profit or loss on disposal.

Investments in subsidiaries

Investments in subsidiaries are stated at cost less any identified impairment loss.

Revenue recognition

When the outcome of a contract for the installation of network systems can be estimated reliably, revenue from fixed price contracts is recognised on the percentage of completion method, measured by reference to the proportion that costs incurred to date bear to estimated total costs for each contract. When the outcome of a contract cannot be estimated reliably, revenue is recognised to the extent of contract costs incurred that it is probable that they are recoverable.

Sales of goods are recognised when goods are delivered and title has passed while service income is recognised when the services are provided.

Interest income is accrued on a time basis, by reference to the principal outstanding and at the interest rate applicable.

Property, plant and equipment

Property, plant and equipment, other than construction in progress are stated at cost less depreciation and amortisation and any identified impairment loss at the balance sheet date.

The gain or loss arising from the disposal or retirement of an asset is determined as the difference between the sales proceeds and the carrying amount of the asset and is recognised in the income statement.

Construction in progress is stated at cost which includes all construction costs and other direct costs attributable to such projects. It is not depreciated until completion of construction. Costs of completed construction works are transferred to the appropriate category of property, plant and equipment.

The cost of land use rights is amortised over the period of the right using the straight line method.

The cost of buildings is depreciated over 30 years using the straight line method.

Depreciation is provided to write off the cost of other property, plant and equipment over their estimated useful lives, using the straight line method, at the rate of 20% per annum.

Borrowing costs

Borrowing costs directly attributable to the acquisition, construction or production of qualifying assets, are capitalised as part of the cost of those assets. Capitalisation of such borrowing costs ceases when the assets are substantially ready for their intended use or sale.

All other borrowing costs are recognised as an expense in the period in which they are incurred.

Technical know-how

Acquired technical know-how is stated at cost less amortisation and any identified impairment loss. Amortisation is calculated to write off the cost of the acquired technical know-how over its estimated useful life of five years, using the straight line method.

The gain or loss arising from the disposal of the acquired technical know-how is determined as the difference between the sales proceeds and the carrying amount of the asset and is recognised in the income statement.

Inventories

Inventories, which represent goods held for sale, are stated at the lower of cost and net realisable value. Cost, which comprises all costs of purchase and, where applicable other costs that have been incurred in bringing the inventories to their present location and condition, is calculated using the weighted average method. Net realisable value represents the estimated selling price in the ordinary course of business less all estimated costs necessary to make the sale.

Installation contracts

When the outcome of a contract for the installation of network systems can be estimated reliably, contract costs are charged to the income statement with reference to the stage of completion of the contract activity at the balance sheet date as measured by reference to the proportion that costs incurred to date bear to estimated costs for each contract.

When the outcome of a contract cannot be estimated reliably, contract costs are recognised as an expense in the period in which they are incurred.

When it is probable that total contract costs will exceed total contract revenue, the expected loss is recognised as an expense immediately.

Impairment

At each balance sheet date, the Group reviews the carrying amounts of its assets to determine whether there is any indication that those assets have suffered an impairment loss. If the recoverable amount of an asset is estimated to be less than its carrying amount, the carrying amount of the asset is reduced to its recoverable amount. Impairment losses are recognised as an expense immediately.

Where an impairment loss subsequently reverses, the carrying amount of the asset is increased to the revised estimate of its recoverable amount, but so that the increased carrying amount does not exceed the carrying amount that would have been determined had no impairment loss been recognised for the asset in prior years. A reversal of an impairment loss is recognised as income immediately.

Research and development costs

Expenditure on research activities is recognised as an expense in the period in which it is incurred.

An internally-generated intangible asset arising from the Group's development expenditure is recognised only if it is anticipated that the development costs incurred on a clearly-defined project will be recovered through future commercial activity. The resultant asset is amortised on a straight line basis over its useful life.

Where no internally-generated intangible asset can be recognised, development expenditure is recognised as an expense in the period in which it is incurred.

Taxation

Income tax expense represents the sum of the tax currently payable and deferred tax.

The tax currently payable is based on taxable profit for the year. Taxable profit differs from net profit as reported in the income statement because it excludes items of income and expense that are taxable or deductible in other years, and it further excludes income statement items that are never taxable and deductible.

Deferred tax is the tax expected to be payable or recoverable on differences between the carrying amounts of assets and liabilities in the financial statements and the corresponding tax bases used in the computation of taxable profit, and is accounted for using the balance sheet liability method. Deferred tax liabilities are generally recognised for all taxable temporary differences, and deferred tax assets are recognised to the extent that it is probable that taxable profits will be available against which deductible temporary differences can be utilised. Such assets and liabilities are not recognised if the temporary difference arises from goodwill (or negative goodwill) or from the initial recognition (other than in a business combination) of other assets and liabilities in a transaction that affects neither the tax profit nor the accounting profit.

Deferred tax liabilities are recognised for taxable temporary differences arising on investments in subsidiaries except where the Group is able to control the reversal of the temporary difference and it is probable that the temporary difference will not reverse in the foreseeable future.

The carrying amount of deferred tax assets is reviewed at each balance sheet date and reduced to the extent that it is no longer probable that sufficient taxable profits will be available to allow all or part of the asset to be recovered.

Deferred tax is calculated at the tax rates that are expected to apply in the period when the liability is settled or the asset realised. Deferred tax is charged or credited in the income statement, except when it relates to items charged or credited directly to equity, in which case the deferred tax is also dealt with in equity.

Foreign currencies

Transactions in foreign currencies are translated at the rates ruling on the dates of the transactions. Monetary assets and liabilities denominated in foreign currencies are re-translated at the rates ruling on the balance sheet date. Gains and losses arising on translation are dealt with in the income statement.

Government grants

Government grants are recognised as income over the periods necessary to match them with the related costs and are deducted in reporting the related expense. Grants related to depreciable assets are presented as a deduction from the carrying amount of the relevant asset and are released to income over the useful lives of the assets. Grants related to expense items are recognised in the same period as those expenses are charged in the income statement and are deducted in reporting the related expense. Where the government grant exceed the expenses incurred and there is no further obligation attached to the government grant, the excess of the government grant over the related expense is recognised as income immediately.

Operating leases

Rentals payable under operating leases are charged to the income statement on a straight line basis over the period of the respective leases.

2. BUSINESS AND GEOGRAPHICAL SEGMENTS

Business segments

For management purposes, the Group's operations are organised into two operating divisions namely provision of video security system solutions and sales of related computer products. These divisions are the basis on which the Group reports its primary business segment information.

Business segments for the Relevant Periods are as follows:

	Turnover			Results		
	Year ended 31 December			Year ended 31 December		
	2001	2002	2003	2001	2002	2003
	RMB'000	RMB'000	RMB'000	RMB'000	RMB'000	RMB'000
Provision of video security system solutions	25,686	49,130	60,875	2,023	17,652	27,242
Sales of related computer products	7,029	13,045	961	(654)	2,651	301
	<u>32,715</u>	<u>62,175</u>	<u>61,836</u>	1,369	20,303	27,543
Other operating income				3,474	3,187	4,542
Central administrative expenses				(3,287)	(5,575)	(6,346)
Profit from operations				1,556	17,915	25,739
Gain on disposal of a subsidiary				–	–	141
Finance costs				(646)	(2,600)	(2,270)
Profit before taxation				910	15,315	23,610
Taxation				(790)	(2,502)	(2,751)
Profit before minority interests				120	12,813	20,859
Minority interests				(55)	(250)	(252)
Net profit for the year				<u>65</u>	<u>12,563</u>	<u>20,607</u>

	At 31 December		
	2001 RMB'000	2002 RMB'000	2003 RMB'000
Assets			
Segment assets			
– provision of video security system solutions	30,643	50,101	40,101
– sales of related computer products	11,576	553	143
Unallocated corporate assets	64,513	58,892	95,799
Total assets	<u>106,732</u>	<u>109,546</u>	<u>136,043</u>
Liabilities			
Segment liabilities			
– provision of video security system solutions	5,988	8,004	11,691
– sales of related computer products	651	953	219
Unallocated corporate liabilities	49,597	41,664	44,501
Total liabilities	<u>56,236</u>	<u>50,621</u>	<u>56,411</u>

	Year ended 31 December		
	2001 RMB'000	2002 RMB'000	2003 RMB'000
Other information			
Capital additions			
– provision of video security system solutions	402	435	224
– sales of related computer products	39	3	–
Unallocated	90	10,565	19,966
	<u>531</u>	<u>11,003</u>	<u>20,190</u>
Depreciation and amortisation			
– provision of video security system solutions	2,152	2,218	1,530
– sales of related computer products	1,162	1,077	–
Unallocated	910	719	770
	<u>4,224</u>	<u>4,014</u>	<u>2,300</u>
Allowance for bad and doubtful debts			
– provision of video security system solutions	–	434	–
– sales of related computer products	–	28	–
Unallocated	–	41	–
	<u>–</u>	<u>503</u>	<u>–</u>
Allowance for inventories			
– provision of video security system solutions	40	455	–
– sales of related computer products	556	–	–
	<u>596</u>	<u>455</u>	<u>–</u>
Write back of allowance for inventories			
– provision of video security system solutions	–	–	40
– sales of related computer products	–	556	–
	<u>–</u>	<u>556</u>	<u>40</u>

Geographical segments

The Group's operations are situated in the PRC in which its revenue was derived principally therefrom. Accordingly, no geographical segments were presented.

3. PROFIT FROM OPERATIONS

Year ended 31 December

	2001	2002	2003
	<i>RMB'000</i>	<i>RMB'000</i>	<i>RMB'000</i>
Profit from operations has been arrived at after charging:			
Directors' and supervisors' remuneration (<i>Note 4</i>)	277	428	476
Other staff's retirement benefits scheme contributions	5	309	225
Other staff costs	4,173	5,657	6,421
	<u>4,455</u>	<u>6,394</u>	<u>7,122</u>
Less: Staff costs included in research and development costs	(718)	(1,214)	(1,789)
	<u>3,737</u>	<u>5,180</u>	<u>5,333</u>
Research and development costs	877	1,666	2,201
Less: Government grants received	–	(996)	(2,201)
	<u>877</u>	<u>670</u>	<u>–</u>
Allowance for bad and doubtful debts	–	503	–
Allowance for inventories	596	455	–
Amortisation of goodwill included in administrative expenses	–	135	135
Amortisation of technical know-how included in administrative expenses	3,260	3,122	1,450
Cost of inventories recognised as expenses	20,717	35,622	26,093
Depreciation and amortisation of property, plant and equipment	964	757	715
Loss on disposal of property, plant and equipment	41	–	5
Operating lease rentals in respect of land and buildings	640	336	633
and after crediting:			
Government grants	–	–	2,022
Interest income	52	96	310
PRC value added tax refunded	–	966	1,409
Write back of allowance for inventories included in cost of sales	–	556	40
	<u>–</u>	<u>556</u>	<u>40</u>

4. DIRECTORS, SUPERVISORS AND EMPLOYEES

Details of emoluments paid by the Group to the directors and supervisors for the Relevant Periods are as follows:

	Year ended 31 December		
	2001 RMB'000	2002 RMB'000	2003 RMB'000
Fees for			
– directors	–	–	–
– supervisors	–	–	–
Other emoluments for non-executive directors	–	–	–
	–	–	–
Other emoluments for executive directors			
– basic salaries and allowances	218	327	378
– retirement benefits scheme contributions	7	14	18
	225	341	396
Other emoluments for a supervisor			
– basic salaries and allowances	48	80	75
– retirement benefits scheme contributions	4	7	5
	52	87	80
	<u>277</u>	<u>428</u>	<u>476</u>

For the year ended 31 December 2001, basic salaries and allowances paid to the three executive directors were RMB72,000, RMB80,000 and RMB66,000 respectively; while contributions to retirement benefits scheme for the two executive directors were RMB4,000 and RMB3,000 respectively. For the same year, basic salaries and allowances paid to one supervisor was RMB48,000 while contributions to retirement benefits scheme for the supervision was RMB4,000.

For the year ended 31 December 2002, basic salaries and allowances paid to the three executive directors were RMB120,000, RMB112,000, RMB95,000 respectively; while contributions to retirement benefits scheme for the two executive directors were RMB7,000 and RMB7,000 respectively. For the same year, basic salaries and allowances paid to one supervisor was RMB80,000 while contributions to retirement benefits scheme for the supervisor was RMB7,000.

For the year ended 31 December 2003, basic salaries and allowances paid to the three executive directors were RMB140,000, RMB128,000 and RMB110,000 respectively; while contributions to retirement benefits scheme for the three executive directors were RMB4,000, RMB7,000, and RMB7,000 respectively. For the same year, basic salaries and allowances paid to one supervisor was RMB75,000 while contributions to retirement benefits scheme for the supervisor was RMB5,000.

The five highest paid individuals included three directors, details of whose emoluments are included above. The emoluments of the remaining two individuals are as follows:

	Year ended 31 December		
	2001	2002	2003
	RMB'000	RMB'000	RMB'000
Employees			
– basic salaries and allowances	124	222	214
– retirement benefits scheme contributions	–	–	5
	<u>124</u>	<u>222</u>	<u>219</u>

During the Relevant Periods, no emoluments were paid by the Group to the five highest paid individuals (including directors, supervisors and employees) as an inducement to join or upon joining the Group or as compensation for loss of office. None of the directors and supervisors has waived any emoluments during the Relevant Periods.

5. TAXATION

	Year ended 31 December		
	2001	2002	2003
	RMB'000	RMB'000	RMB'000
The charge comprises:			
PRC income tax	(546)	(2,281)	(2,834)
Deferred taxation	(244)	(221)	83
	<u>(790)</u>	<u>(2,502)</u>	<u>(2,751)</u>

PRC income tax is calculated at the rates prevailing under the relevant laws and regulations in the PRC.

The Company is recognised as a high-technology company according to PRC tax regulations and is entitled to a preferential tax rate of 15%.

The Company's subsidiaries are subject to a PRC income tax rate of 33%, except for Nanjing Golden Dragon Software Company Limited, being a qualified PRC software enterprise, which is entitled to exemption from PRC income tax for two years commencing from its first profit-making year of operation and thereafter it will be entitled to a 50% relief from PRC income tax for the following three years. This subsidiary is exempted from PRC income tax in 2002 and 2003.

The charge for the Relevant Periods is reconciled to the profit per the income statement as follows:

	Year ended 31 December					
	2001		2002		2003	
	RMB'000	%	RMB'000	%	RMB'000	%
Profit before taxation	<u>910</u>		<u>15,315</u>		<u>23,610</u>	
Tax at the domestic income tax rate of 15%	136	15.0	2,297	15.0	3,542	15.0
Tax effect of expenses that are not deductible in determining taxable profit	356	39.1	538	3.5	364	1.5
Tax effect of income that are not taxable in determining taxable profit	–	–	(323)	(2.1)	(364)	(1.5)
Effect of different tax rates of subsidiaries	<u>298</u>	<u>32.7</u>	<u>(10)</u>	<u>(0.1)</u>	<u>(791)</u>	<u>(3.4)</u>
Tax expense and effective tax rate for the year	<u>790</u>	<u>86.8</u>	<u>2,502</u>	<u>16.3</u>	<u>2,751</u>	<u>11.6</u>

6. DIVIDENDS

No dividends have been declared by the Company and its subsidiaries during the Relevant Periods, except for Nanjing Sample Information System Engineering Company Limited which paid dividends of RMB1,608,000 in 2001, of which RMB691,000 was paid to its then minority owners.

The rates of dividends and the number of shares ranking for dividends are not presented as such information is not meaningful having regard to the purpose of this report.

7. EARNINGS PER SHARE

The calculation of basic earnings per share is based on the consolidated net profit for the Relevant Periods and 45,000,000 shares in issue during the Relevant Periods.

8. PROPERTY, PLANT AND EQUIPMENT

	Land and buildings RMB'000	Furniture, fixtures and equipment RMB'000	Motor vehicles RMB'000	Construction in progress RMB'000	Total RMB'000
THE GROUP					
COST					
At 1 January 2001	–	1,846	1,332	59	3,237
Additions	–	422	95	14	531
Disposals	–	(83)	–	–	(83)
Transfers	–	12	–	(12)	–
At 31 December 2001	–	2,197	1,427	61	3,685
Additions	–	357	337	713	1,407
Transfers	–	82	–	(82)	–
At 31 December 2002	–	2,636	1,764	692	5,092
Additions	7,520	291	487	11,892	20,190
Eliminated on disposal of a subsidiary	–	(134)	–	–	(134)
Disposals	–	(94)	–	–	(94)
Transfers	1,100	–	–	(1,100)	–
At 31 December 2003	8,620	2,699	2,251	11,484	25,054
DEPRECIATION AND AMORTISATION					
At 1 January 2001	–	467	376	–	843
Provided for the year	–	421	543	–	964
Eliminated on disposals	–	(42)	–	–	(42)
At 31 December 2001	–	846	919	–	1,765
Provided for the year	–	491	266	–	757
At 31 December 2002	–	1,337	1,185	–	2,522
Provided for the year	50	468	197	–	715
Eliminated on disposal of a subsidiary	–	(24)	–	–	(24)
Eliminated on disposals	–	(89)	–	–	(89)
At 31 December 2003	50	1,692	1,382	–	3,124
NET BOOK VALUES					
At 31 December 2003	8,570	1,007	869	11,484	21,930
At 31 December 2002	–	1,299	579	692	2,570
At 31 December 2001	–	1,351	508	61	1,920

	Land and buildings RMB'000	Furniture, fixtures and equipment RMB'000	Motor vehicles RMB'000	Construction in progress RMB'000	Total RMB'000
THE COMPANY					
COST					
At 1 January 2001	–	872	274	–	1,146
Additions	–	349	95	12	456
Disposals	–	(74)	–	–	(74)
Transfers	–	12	–	(12)	–
	<u>–</u>	<u>12</u>	<u>–</u>	<u>(12)</u>	<u>–</u>
At 31 December 2001	–	1,159	369	–	1,528
Additions	–	160	337	713	1,210
Transfers	–	21	–	(21)	–
	<u>–</u>	<u>21</u>	<u>–</u>	<u>(21)</u>	<u>–</u>
At 31 December 2002	–	1,340	706	692	2,738
Additions	7,520	255	487	11,892	20,154
Transfers	1,100	–	–	(1,100)	–
	<u>1,100</u>	<u>–</u>	<u>–</u>	<u>(1,100)</u>	<u>–</u>
At 31 December 2003	<u>8,620</u>	<u>1,595</u>	<u>1,193</u>	<u>11,484</u>	<u>22,892</u>
DEPRECIATION AND AMORTISATION					
At 1 January 2001	–	195	41	–	236
Provided for the year	–	227	56	–	283
Eliminated on disposals	–	(39)	–	–	(39)
	<u>–</u>	<u>(39)</u>	<u>–</u>	<u>–</u>	<u>(39)</u>
At 31 December 2001	–	383	97	–	480
Provided for the year	–	258	88	–	346
	<u>–</u>	<u>258</u>	<u>88</u>	<u>–</u>	<u>346</u>
At 31 December 2002	–	641	185	–	826
Provided for the year	50	254	190	–	494
	<u>50</u>	<u>254</u>	<u>190</u>	<u>–</u>	<u>494</u>
At 31 December 2003	<u>50</u>	<u>895</u>	<u>375</u>	<u>–</u>	<u>1,320</u>
NET BOOK VALUES					
At 31 December 2003	<u>8,570</u>	<u>700</u>	<u>818</u>	<u>11,484</u>	<u>21,572</u>
At 31 December 2002	<u>–</u>	<u>699</u>	<u>521</u>	<u>692</u>	<u>1,912</u>
At 31 December 2001	<u>–</u>	<u>776</u>	<u>272</u>	<u>–</u>	<u>1,048</u>

The Group's land and buildings which are situated in the PRC are held under medium term land use rights.

No interest was capitalised under construction in progress.

9. INVESTMENTS IN SUBSIDIARIES

	THE COMPANY		
	At 31 December		
	2001	2002	2003
	<i>RMB'000</i>	<i>RMB'000</i>	<i>RMB'000</i>
Unlisted capital contributions, at cost	18,240	23,300	23,300

10. TECHNICAL KNOW-HOW

	THE GROUP	THE COMPANY
	<i>RMB'000</i>	<i>RMB'000</i>
COST		
At 1 January 2001 and 31 December 2001	16,300	9,300
Disposals	(8,300)	(8,300)
At 31 December 2002 and 31 December 2003	8,000	1,000
AMORTISATION		
At 1 January 2001	3,377	2,210
Amortised for the year	3,260	1,860
At 31 December 2001	6,637	4,070
Amortised for the year	3,122	1,722
Eliminated on disposals	(4,842)	(4,842)
At 31 December 2002	4,917	950
Amortised for the year	1,450	50
At 31 December 2003	6,367	1,000
CARRYING VALUE		
At 31 December 2003	1,633	—
At 31 December 2002	3,083	50
At 31 December 2001	9,663	5,230

II. GOODWILL

	<i>RMB'000</i>
THE GROUP	
COST	
At 1 January 2001 and 31 December 2001	–
Arising during the year	676
	<u>676</u>
At 31 December 2002 and 31 December 2003	676
	<u>676</u>
AMORTISATION	
At 1 January 2001 and 31 December 2001	–
Amortised for the year and balance at 31 December 2002	135
Amortised for the year	135
	<u>135</u>
At 31 December 2003	270
	<u>270</u>
CARRYING VALUE	
At 31 December 2003	406
	<u><u>406</u></u>
At 31 December 2002	541
	<u><u>541</u></u>
At 31 December 2001	–
	<u><u>–</u></u>

12. DEPOSITS MADE ON ACQUISITION OF PROPERTY, PLANT AND EQUIPMENT

The deposits were paid by the Company in connection with the acquisition of a piece of land situated in the PRC.

13. DEFERRED TAX ASSETS

The followings are the major deferred tax assets recognised by the Group and the Company and movements thereon during the Relevant Periods:

	Amortisation of technical know-how <i>RMB'000</i>	Pre- operating expenses <i>RMB'000</i>	Allowance for bad and doubtful debts <i>RMB'000</i>	Allowance for inventories <i>RMB'000</i>	Tax losses <i>RMB'000</i>	Total <i>RMB'000</i>
THE GROUP						
At 1 January 2001	267	166	17	–	873	1,323
Credit (charge) to income for the year	277	(59)	–	90	(552)	(244)
At 31 December 2001	544	107	17	90	321	1,079
Credit (charge) to income for the year	(105)	(27)	76	(15)	(150)	(221)
At 31 December 2002	439	80	93	75	171	858
Credit (charge) to income for the year	116	(26)	–	(7)	–	83
Eliminated on disposal of a subsidiary	–	–	–	–	(171)	(171)
At 31 December 2003	<u>555</u>	<u>54</u>	<u>93</u>	<u>68</u>	<u>–</u>	<u>770</u>
THE COMPANY						
At 1 January 2001	267	166	17	–	6	456
Credit (charge) to income for the year	277	(59)	–	90	(6)	302
At 31 December 2001	544	107	17	90	–	758
Credit (charge) to income for the year	(105)	(27)	76	(15)	–	(71)
At 31 December 2002	439	80	93	75	–	687
Credit (charge) to income for the year	116	(26)	–	(7)	–	83
At 31 December 2003	<u>555</u>	<u>54</u>	<u>93</u>	<u>68</u>	<u>–</u>	<u>770</u>

14. AMOUNTS DUE FROM CUSTOMERS FOR CONTRACT WORK

	At 31 December		
	2001 <i>RMB'000</i>	2002 <i>RMB'000</i>	2003 <i>RMB'000</i>
THE GROUP			
Contract costs incurred to date	24,160	50,676	48,728
Recognised profits less recognised losses	10,814	24,005	17,158
	<u>34,974</u>	<u>74,681</u>	<u>65,886</u>
Less: Progress billings	(33,757)	(71,011)	(63,257)
	<u>1,217</u>	<u>3,670</u>	<u>2,629</u>
THE COMPANY			
Contract costs incurred to date	14,929	41,292	46,824
Recognised profits less recognised losses	5,347	18,538	16,070
	<u>20,276</u>	<u>59,830</u>	<u>62,894</u>
Less: Progress billings	(19,369)	(56,160)	(60,265)
	<u>907</u>	<u>3,670</u>	<u>2,629</u>

15. TRADE AND OTHER RECEIVABLES

	THE GROUP		
	At 31 December		
	2001 <i>RMB'000</i>	2002 <i>RMB'000</i>	2003 <i>RMB'000</i>
Trade receivables	16,002	30,794	29,421
Other receivables	720	8,527	7,439
Prepayments to suppliers	654	9,521	3,433
	<u>17,376</u>	<u>48,842</u>	<u>40,293</u>

Payment terms with customers are mainly on credit together with deposits. Invoices are normally payable within 180 days of issuance, except for certain well established customers. The following is an aged analysis of trade receivables at the balance sheet dates:

	THE GROUP		
	At 31 December		
	2001	2002	2003
	<i>RMB'000</i>	<i>RMB'000</i>	<i>RMB'000</i>
Age			
0 to 90 days	8,516	29,442	29,421
91 to 180 days	1,396	470	—
181 to 365 days	2,265	415	—
1 to 2 years	2,920	467	—
Over 2 years	905	—	—
	<u>16,002</u>	<u>30,794</u>	<u>29,421</u>

16. AMOUNTS DUE FROM RELATED PARTIES

	At 31 December		
	2001	2002	2003
	<i>RMB'000</i>	<i>RMB'000</i>	<i>RMB'000</i>
THE GROUP			
Amounts due from			
– shareholders	28,236	—	—
– directors	323	46	—
– supervisor	15	150	—
	<u>28,574</u>	<u>196</u>	<u>—</u>
THE COMPANY			
Amounts due from			
– shareholders	18,860	—	—
– directors	23	71	—
– supervisor	15	150	—
	<u>18,898</u>	<u>221</u>	<u>—</u>

The amounts due from related parties were unsecured, interest-free and were fully repaid in 2003.

17. TRADE AND OTHER PAYABLES

	THE GROUP		
	At 31 December		
	2001	2002	2003
	<i>RMB'000</i>	<i>RMB'000</i>	<i>RMB'000</i>
Trade payables	4,264	4,277	8,245
Other payables	5,638	6,712	5,968
	<u>9,902</u>	<u>10,989</u>	<u>14,213</u>

The following is an aged analysis of trade payables at the balance sheet dates:

	THE GROUP		
	At 31 December		
	2001	2002	2003
	<i>RMB'000</i>	<i>RMB'000</i>	<i>RMB'000</i>
Age			
0 to 30 days	2,781	1,518	4,554
31 to 60 days	426	1,436	446
61 to 90 days	792	650	337
Over 90 days	265	673	2,908
	<u>4,264</u>	<u>4,277</u>	<u>8,245</u>

18. AMOUNTS DUE TO RELATED PARTIES

	At 31 December		
	2001	2002	2003
	<i>RMB'000</i>	<i>RMB'000</i>	<i>RMB'000</i>
THE GROUP			
Amounts due to			
– a fellow subsidiary	858	–	–
– shareholders	–	3,934	–
– director	–	14	–
	<u>858</u>	<u>3,948</u>	<u>–</u>
THE COMPANY			
Amounts due to			
– a fellow subsidiary	410	–	–
– shareholders	–	4,105	–
	<u>410</u>	<u>4,105</u>	<u>–</u>

The amounts due to related parties were unsecured, interest-free and were fully repaid in 2003.

19. LONG-TERM BANK LOANS

The bank loans, of which RMB5,000,000 and RMB10,000,000 were repayable in October 2005 and June 2006 respectively, are unsecured, carry interest at the prevailing market rate and are wholly guaranteed by a shareholder of the Company, Nanjing Sample Technology Group Company Limited ("Sample Group"). The directors have obtained an undertaking from the bank in December 2003 for the release of this guarantee and substituted by guarantees in the form of the Company's credit upon the listing of the Company's securities on the Growth Enterprise Market on The Stock Exchange of Hong Kong Limited.

20. SHARE CAPITAL

	Registered and fully paid <i>RMB'000</i>
Shares of RMB1 each	45,000

21. RESERVES

	Statutory surplus reserve <i>RMB'000</i>	Statutory welfare fund <i>RMB'000</i>	Retained profits (deficit) <i>RMB'000</i>	Total <i>RMB'000</i>
THE COMPANY				
At 1 January 2001	65	33	(2,656)	(2,558)
Net profit for the year	—	—	1,151	1,151
At 31 December 2001	65	33	(1,505)	(1,407)
Net profit for the year	—	—	10,206	10,206
Transfers	866	433	(1,299)	—
At 31 December 2002	931	466	7,402	8,799
Net profit for the year	—	—	14,847	14,847
Transfers	2,167	1,083	(3,250)	—
At 31 December 2003	<u>3,098</u>	<u>1,549</u>	<u>18,999</u>	<u>23,646</u>

As stipulated by the relevant laws and regulations in the PRC, the Company is required to set aside 10% of its profit after taxation for the statutory surplus reserve (except where the reserve has reached 50% of the Company's registered capital) and 5% to 10% of its profit after taxation for the statutory welfare fund.

According to the Company's Articles of Association, statutory surplus reserve can be used to (i) make up prior year losses; (ii) convert into capital, provided such conversion is approved by a resolution at a shareholders' meeting and the balance of the statutory surplus reserve does not fall below 25% of the Company's registered capital; or (iii) expand production operation.

The statutory welfare fund, which is to be used for the welfare of the staff and workers of the Company, is of a capital nature.

In accordance with the Company's Articles of Association, the profit after taxation for the purpose of appropriation will be deemed to be the lesser of the amounts determined in accordance with (i) PRC accounting standards and regulations and (ii) either International Accounting Standards or overseas accounting standards of the place in which the Company's shares are listed.

22. DISPOSAL OF A SUBSIDIARY

In January 2003, the Group disposed of its indirect subsidiary Shanghai Common Data Technologies Company Limited to an independent third party for a consideration of RMB540,000.

	Year ended 31 December		
	2001	2002	2003
	<i>RMB'000</i>	<i>RMB'000</i>	<i>RMB'000</i>
Net assets disposed of:			
Property, plant and equipment	–	–	110
Deferred tax assets	–	–	171
Trade and other receivables	–	–	382
Bank balances and cash	–	–	3
Trade and other payables	–	–	(115)
Minority interests	–	–	(152)
	<u>–</u>	<u>–</u>	<u>–</u>
Net assets	–	–	399
Gain on disposal of a subsidiary	–	–	141
	<u>–</u>	<u>–</u>	<u>540</u>
Satisfied by:			
Cash consideration received	<u>–</u>	<u>–</u>	<u>540</u>
Analysis of net inflow of cash and cash equivalents in connection with the disposal of the subsidiary:			
Cash consideration received	–	–	540
Bank balances and cash disposed of	–	–	(3)
	<u>–</u>	<u>–</u>	<u>–</u>
Net inflow of cash and cash equivalents in connection with the disposal of the subsidiary	<u>–</u>	<u>–</u>	<u>537</u>

The subsidiary disposed of did not have any significant impact on the Group's operating results.

23. OPERATING LEASE COMMITMENTS

At the balance sheet dates, the Group and the Company was committed to make the following future minimum lease payments in respect of land and buildings rented under non-cancellable operating leases which fall due as follows:

	At 31 December		
	2001	2002	2003
	<i>RMB'000</i>	<i>RMB'000</i>	<i>RMB'000</i>
THE GROUP			
Within one year	250	280	580
	<u>250</u>	<u>280</u>	<u>580</u>
THE COMPANY			
Within one year	250	280	461
	<u>250</u>	<u>280</u>	<u>461</u>

24. CAPITAL COMMITMENTS

	THE GROUP AND THE COMPANY		
	At 31 December		
	2001	2002	2003
	<i>RMB'000</i>	<i>RMB'000</i>	<i>RMB'000</i>
Capital expenditure contracted for but not provided in the financial statements in respect of the acquisition of property, plant and equipment	880	700	11,218
	<u>880</u>	<u>700</u>	<u>11,218</u>

25. CONTINGENT LIABILITIES

	THE GROUP AND THE COMPANY		
	At 31 December		
	2001	2002	2003
	<i>RMB'000</i>	<i>RMB'000</i>	<i>RMB'000</i>
Guarantees given to banks in respect of credit facilities granted to			
– a beneficial shareholder of the Company	30,000	–	–
– a jointly controlled entity held by a shareholder of the Company	20,000	20,000	–
– a shareholder of the Company	4,000	–	–
	<u>54,000</u>	<u>20,000</u>	<u>–</u>

26. RETIREMENT BENEFITS SCHEME

The employees of the Group are members of the state-managed retirement benefits scheme operated by the PRC government. The Group is required to contribute a certain percentage of its payroll to the retirement benefits scheme to fund the benefits. The only obligation of the Group with respect to the retirement benefits scheme is to make the required contributions under the scheme.

27. RELATED PARTY TRANSACTIONS

During the Relevant Periods, the Group has the following significant transactions with related companies:

Name of related companies	Nature of transactions	THE GROUP		
		Year ended 31 December		
		2001	2002	2003
		RMB'000	RMB'000	RMB'000
<i>Companies controlled by a shareholder</i>				
<i>Sample Group:</i>				
Nanjing Sample Computer Trading Company Limited	Sales of computer products (Note i)	44	7,509	–
	Purchase of computer products (Note i)	1,718	1,541	–
Shanghai Sample Information Technology Company Limited	Provision of system solution services (Note i)	900	–	–
Shanghai Sample Computer Company Limited	Sales of computer products (Note i)	–	258	–
<i>Shareholders:</i>				
Sample Group	Acquisition of additional interests in a subsidiary (Note ii)	–	5,060	–
Nanjing Sample Technology Commerce City Company Limited	Property rentals paid (Note i)	640	250	104

Notes:

- i. These transactions were carried out on terms mutually agreed between the Group and the related companies.
- ii. The consideration for the acquisition of additional interests in a subsidiary was paid in accordance with the terms of an agreement mutually agreed between the Company and a Company's shareholder, Sample Group.

In the opinion of the directors, the above transactions were carried out in the Group's ordinary and usual course of business and in accordance with the terms of the agreements governing these transactions. These transactions will not continue in the future.

The Company and Sample Group entered into a licence agreement on 1 January 2001 pursuant to which Sample Group agreed to grant a licence to the Company for the use of the trademarks "SAMPLE" and "神保" at nil consideration with effect from 1 January 2001. Pursuant to a supplemental agreement to the licence agreement dated 2 April 2004 ("Supplemental Agreement"), Sample Group irrevocably agreed to grant a licence to the Company for (i) the use of the trademark "SAMPLE"; and (ii) the exclusive use of the trademark "神保" in connection with the services included in class 42 at nil consideration. The licence period for (i) commences retrospectively on 1 January 2001 until 31 July 2008 whilst the licence period for (ii) commences retrospectively on 1 January 2001 until the earlier of (a) 31 July 2008; and (b) the date when the necessary procedures for the transfer of the trademark have been completed pursuant to the exercise of the option under the trademark option agreement dated 1 August 2003. Under the Supplemental Agreement, Sample Group retains the right to use the trademark "SAMPLE" in connection with services included in class 42 and the Company was granted a pre-emptive right to acquire the trademarks "SAMPLE" and "神保" should Sample Group intend to transfer the same to third parties under the same terms and conditions after the expiry of the Supplementary Agreement.

In addition, the Company and Sample Group entered into a trademark option agreement dated 1 August 2003 pursuant to which an option was granted to the Company by Sample Group exercisable from the date of the trademark option agreement to 31 July 2008 ("Option Period"). During the Option Period, the Company may, by written notice, request Sample Group to transfer the "神保" trademark to the Company at nil consideration.

At the balance sheet dates, certain of the Group's short-term bank loans are secured by guarantees given by related companies:

	At 31 December		
	2001	2002	2003
	RMB'000	RMB'000	RMB'000
Guarantees given by a jointly controlled entity held by a shareholder of the Company	<u>20,000</u>	<u>20,000</u>	<u>—</u>

G. DIRECTORS' AND SUPERVISORS' REMUNERATION

Save as disclosed herein, no remuneration has been paid or is payable to the Company's directors and supervisors by the Company or any of its subsidiaries during the Relevant Periods.

Under the arrangements presently in force the aggregate remuneration of the Company's directors and supervisors for the year ending 31 December 2004 is approximately RMB824,000 and RMB150,000 respectively.

H. SUBSEQUENT EVENTS

The following events have occurred subsequent to 31 December 2003:

- (a) On 26 March 2004, the China Securities Regulatory Commission issued an approval consenting to the Company to issue H shares and list on the Growth Enterprise Market of The Stock Exchange of Hong Kong Limited.
- (b) On 24 April 2004, shareholders' resolutions were passed to approve the matters set out in item 7 in the paragraph headed "Shareholders' resolutions, undertaking and approval in chronological order" in Appendix VII to the Prospectus.

I. SUBSEQUENT FINANCIAL STATEMENTS

No audited financial statements of the Group, the Company or any of its subsidiaries have been prepared in respect of any period subsequent to 31 December 2003.

Yours faithfully,
Deloitte Touche Tohmatsu
Certified Public Accountants
Hong Kong

For illustrative purposes only, the pro forma financial information prepared in accordance with Rule 7.31 of the GEM Listing Rules is set out below to provide the investors with further information how the Placing might have affected the financial position of the Group after completion of the Placing.

Although reasonable care has been exercised in preparing the said information, prospective investors who read the information should bear in mind that these figures are inherently subject to adjustments and may not give a true picture of the financial position of the Group after the completion of the Placing.

A. PRO FORMA ADJUSTED NET TANGIBLE ASSETS

The following is an illustrative statement of pro forma adjusted net tangible assets of the Group which has been prepared in accordance with Rule 7.31 of the GEM Listing Rules for the purpose of illustrating the effect of the Placing to the net tangible assets of the Group as if the Placing had been taken place on 31 December 2003 and based on the audited consolidated net tangible assets of the Group as at 31 December 2003 as shown in the accountants' report, the text of which is set out in Appendix I to this prospectus, and adjusted as follows:

	Audited consolidated net tangible assets of the Group as at 31 December 2003 <i>RMB'000</i> <i>(Note 1)</i>	Estimated net proceeds from the Placing of the New H Shares <i>RMB'000</i> <i>(Note 2)</i>	Adjusted net tangible assets <i>RMB'000</i>	Adjusted net tangible assets value per Share <i>(Note 3)</i>
Based on the Placing Price of HK\$2.70 per H Share	<u>72,786</u>	<u>43,960</u>	<u>116,746</u>	RMB1.81 (approximately HK\$1.71)
Based on the Placing Price of HK\$4.60 per H Share	<u>72,786</u>	<u>81,568</u>	<u>154,354</u>	RMB2.39 (approximately HK\$2.25)

This statement has been prepared for illustrative purposes only and because of its nature, it may not give a true picture of the financial position of the Group after the completion of the Placing.

Notes:

- Such information is based on the audited consolidated balance sheet of the Group as at 31 December 2003 as shown in the accountants' report, the text of which is set out in Appendix I to this prospectus.
- The estimated net proceeds from the Placing of the New H Shares are derived after deducting related listing expenses and underwriting commission payable by the Company.
- The adjusted net tangible asset value per Share is arrived at based on 64,500,000 Shares in issue immediately following the completion of the Placing (without taking into account any Shares which may fall to be issued upon the exercise of any options granted under the Share Option Scheme).

4. The surplus arising from the revaluation of the Group's land and buildings as at 30 April 2004 as detailed in the valuation report in Appendix III to this prospectus amounted to approximately RMB10.1 million will not be incorporated in the financial statements of the Group for the year ending 31 December 2004. If the surplus would be incorporated in the Group's financial statements for the year ending 31 December 2004, the annual depreciation charge of the Group would increase by no more than RMB208,000.

B. COMFORT LETTER ON THE PRO FORMA STATEMENT OF ADJUSTED NET TANGIBLE ASSETS OF THE GROUP

Deloitte.
德勤

德勤·關黃陳方會計師行
香港中環干諾道中111號
永安中心26樓

Deloitte Touche Tohmatsu
26/F Wing On Centre
111 Connaught Road Central
Hong Kong

2 June 2004

The Directors
Nanjing Sample Technology Company Limited
Room 103, Building No.1 Ruan Jian Chuang Ye Zhong Xin
High Technology Development Region
Nanjing City
Jiangsu Province
The People's Republic of China

Dear Sirs,

We report on the pro forma statement of adjusted net tangible assets of the Group set out in section A of Appendix II to the prospectus dated 2 June 2004 (the "Prospectus") in connection with the placing of the H shares of Nanjing Sample Technology Company Limited (the "Company"), which has been prepared, for illustrative purposes only, to provide information about how the placing of the Company's H shares might have affected the net tangible assets of the Company and its subsidiaries (the "Group").

RESPONSIBILITIES

It is the responsibility solely of the directors of the Company to prepare the pro forma statement of adjusted net tangible assets in accordance with paragraph 31 of Chapter 7 of the Rules Governing the Listing of Securities on the Growth Enterprise Market of The Stock Exchange of Hong Kong Limited (the "GEM Listing Rules").

It is our responsibility to form an opinion, as required by the GEM Listing Rules, on the pro forma statement of adjusted net tangible assets and to report our opinion to you. We do not accept any responsibility for any reports previously given by us on any financial information used in the compilation of the pro forma financial information beyond that owed to those to whom those reports were addressed by us at the dates of their issue.

BASIS OF OPINION

We conducted our work in accordance with the Statements of Investment Circular Reporting Standards and Bulletin 1998/8 “Reporting on pro forma financial information pursuant to the listing rules” issued by the Auditing Practice Board in the United Kingdom, where applicable. Our work, which involved no independent examination of any of the underlying financial information, consisted primarily of comparing the unadjusted financial information with the source documents, considering the evidence supporting the adjustments and discussing the pro forma statement of adjusted net tangible assets with the directors of the Company.

Our work does not constitute an audit or review in accordance with Statements of Auditing Standards issued by the Hong Kong Society of Accountants, and accordingly, we do not express any such assurance on the pro forma statement of adjusted net tangible assets.

The pro forma statement of adjusted net tangible assets has been compiled in accordance with the basis set out in the first paragraph of this letter for illustrative purposes only and, because of its nature, it may not give an indicative net tangible assets value of the Group as at 31 December 2003 or at any future date.

OPINION

In our opinion:

- (a) the pro forma statement of adjusted net tangible assets has been properly compiled on the basis stated;
- (b) such basis is consistent with the accounting policies of the Group; and
- (c) the adjustments are appropriate for the purposes of the pro forma statement of adjusted net tangible assets as disclosed pursuant to paragraph 31 of Chapter 7 of the GEM Listing Rules.

Yours faithfully,
Deloitte Touche Tohmatsu
Certified Public Accountants
Hong Kong

The following is the text of a letter together with the summary of valuation and valuation certificates from Vigers Appraisal & Consulting Limited, an independent property valuer, in connection with their opinion of values of the property interests of the Group as at 30 April 2004.

Vigers Appraisal & Consulting Limited
International Asset Appraisal Consultants

10th Floor,
The Grande Building
398 Kwun Tong Road
Kowloon
Hong Kong



2 June 2004

The Directors
Nanjing Sample Technology Company Limited
Room 103, Building No. 1, Ruan Jian Chuang Ye Zhong Xin,
High Technology Development Region,
Nanjing City,
Jiangsu Province,
The People's Republic of China

Dear Sirs,

In accordance with your instructions for us to value the property interests of Nanjing Sample Technology Company Limited (the "Company") and its subsidiaries (together referred to as the "Group") in the People's Republic of China (the "PRC"), we confirm that we have carried out inspections, made relevant enquiries and obtained such further information as we consider necessary for the purpose of providing you with our opinion of the open market value of such property interests as at 30 April 2004 ("the date of valuation").

Our valuation of the interests in property is our opinion of the open market value which we would define as intended to mean – "the best price at which the sale of an interest in property would have been completed unconditionally for cash consideration on the date of valuation assuming: –

- (a) a willing seller;
- (b) that, prior to the date of valuation, there had been a reasonable period (having regard to the nature of the property and the state of the market) for the proper marketing of the interest, for the agreement of price and terms and for the completion of the sale;
- (c) that the state of the market, level of values and other circumstances were, on any earlier assumed date of exchange of contracts, the same as on the date of valuation;

- (d) that no account is taken of any additional bid by a prospective purchaser with a special interest; and
- (e) that both parties to the transaction had acted knowledgeably, prudently and without compulsion."

Our valuations have been made on the assumption that the owner sells the relevant properties in the open market in their existing state without the benefit of deferred term contract, leaseback, joint venture, management agreement or any similar arrangement which would serve to affect the values of such property interests. In addition, no forced sale situation in any manner is assumed in our valuations.

In valuing property No. 1 in Group I, which is held by the Group in the PRC, we have adopted a combination of the open market and depreciated replacement cost approaches in assessing the land portions of the property and the buildings and structures standing on the land respectively. Hence, the sum of the two results represents the market value of the property as a whole. In the valuation of the land portions, reference has been made to the standard land price in Nanjing City and the sales comparables in the locality. As the nature of the buildings and structures cannot be valued on the basis of open market value, they have therefore been valued on the basis of their depreciated replacement cost. The depreciated replacement cost approach considers the cost to reproduce or replace in new condition the property appraised in accordance with current construction costs for similar buildings and structures in the locality, with allowance for accrued depreciation as evidenced by observed condition or obsolescence present, whether arising from physical, functional or economic causes. The depreciated replacement cost approach generally furnishes the most reliable indication of value for property in the absence of a known market based on comparable sales.

We have valued property No. 2 in Group I with reference to sale evidence as available in the market.

The property interests in Group II, which are rented and occupied by the Group, have no commercial value due mainly to the short term nature of the tenancy or the prohibitions against assignment or sub-letting or otherwise due to the lack of substantial and marketable profit rents.

In undertaking our valuation of the properties in Group I and II, we have relied on the legal opinion provided by Commerce and Finance Law Offices, the Group's PRC legal adviser (the "PRC Legal Opinion").

We have inspected the exterior and, where possible, the interior of the properties included in the attached valuation certificates. However, we have not carried out a structural survey. We are therefore unable to report whether any such parts of the property interests are free from decay, damage by insects or any other structural defects. However, in the course of our inspection, we have not discovered any serious defects.

We have relied to a very considerable extent on the information provided by the Group and the PRC Legal Opinion and have accepted advice given to us on matters such as planning approvals, statutory notices, easements, tenure, particulars of occupancy, lettings, rental income and revenue, joint venture agreements, development plans, construction costs estimates, site and floor areas, the identification of those properties in which the Group has valid interests and all other relevant matters. Dimensions, measurements and areas included in the valuation certificates are based on information contained in copies of documents provided to us and are therefore only approximations.

We have had no reason to doubt the truth and accuracy of the information provided to us by the Group. We were also advised by the Group that no material factors have been omitted from the information supplied. We consider that we have been provided with sufficient information to reach an informed view, and have no reason to suspect that any material information has been withheld.

No allowance has been made in our valuations for any charges, mortgages or amounts owing on the properties nor for any expenses or taxation which may be incurred in effecting a sale. Unless otherwise stated, it is assumed that the properties are free from encumbrances, restrictions and outgoings of an onerous nature which could affect their values.

In valuing the property interests, we have complied with all the requirements contained in Chapter 8 of the Rules Governing the Listing of Securities on the Growth Enterprise Market of The Stock Exchange of Hong Kong Limited. Our valuations have also been prepared in accordance with the Hong Kong Guidance Notes on Valuation of Property Assets (2nd Edition) published by the Hong Kong Institute of Surveyors in March 2003.

Unless otherwise stated, all monetary amounts stated are in Renminbi. The exchange rate used in valuing the property interests in the PRC on 30 April 2004 was HK\$1=RMB1.06. There has been no significant fluctuation in exchange rate between the date of valuation and the date of this letter.

We enclose herewith a summary of our valuation and the valuation certificates.

Yours faithfully,

For and on behalf of

VIGERS APPRAISAL & CONSULTING LIMITED

Raymond Ho Kai Kwong

Registered Professional Surveyor

MRICS, MHKIS, MSc (e-com)

Executive Director

Note: Raymond K.K. Ho, Chartered Surveyor, MRICS, MHKIS, MSc (e-com) has over seventeen years' experience in undertaking valuations of properties in Hong Kong and Macau and has over ten years' experience in the valuation of properties in the PRC.

SUMMARY OF VALUATION

Property	Open market value in existing state as at 30 April 2004
Group I - Property interests held by the Group in the PRC	
1. A parcel of land located at Ke Ji Yuan, Qixia District, Nanjing City, Jiangsu Province, The PRC	RMB16,000,000 equivalent to HK\$15,094,000
2. Villa B4, Gao Xin Area, Pu Kou District, Nanjing City, Jiangsu Province, The PRC	RMB1,000,000 equivalent to HK\$943,000
Sub-total:	RMB17,000,000 equivalent to HK\$16,037,000
Group II - Property interests rented and occupied by the Group in the PRC	
3. Room 702-1, Level 7, Block No. 54, Cheng Chang Development Zone, Jiangsu Software Park, No. 168 Longpan Zhong Road, Nanjing City, Jiangsu Province, The PRC	No commercial value
4. Room 702-2, Level 7, Block No. 54, Cheng Chang Development Zone, Jiangsu Software Park, No. 168 Longpan Zhong Road, Nanjing City, Jiangsu Province, The PRC	No commercial value
5. Room 702-3, Level 7, Block No. 54, Cheng Chang Development Zone, Jiangsu Software Park, No. 168 Longpan Zhong Road, Nanjing City, Jiangsu Province, The PRC	No commercial value
6. Room 701-3, Level 7, Block No. 54, Cheng Chang Development Zone, Jiangsu Software Park, No. 168 Longpan Zhong Road, Nanjing City, Jiangsu Province, The PRC	No commercial value
Sub-total:	Nil
Grand-Total:	RMB17,000,000 equivalent to HK\$16,037,000

VALUATION CERTIFICATE

Group I - Property interests held by the Group in the PRC

Property	Description and tenure	Particulars of occupancy	Open market value in existing state as at 30 April 2004
1. A parcel of land located at Ke Ji Yuan, Qixia District, Nanjing City, Jiangsu Province, The PRC	The property comprises a parcel of land with a site area of approximately 50,117 sq.m. The property was granted with land use rights for a term expiring on 17 August 2053.	The property is under construction	RMB16,000,000 equivalent to HK\$15,094,000

Notes:

1. According to a State-owned Land Use Rights Grant Contract dated 20 August 2003 entered into between Nanjing City State-owned Land Resources Bureau ("Party A") and Nanjing Sample Technology Company Limited ("Party B"), Party A agreed to sell the land use rights of the property to Party B at a consideration of RMB6,014,040.
2. According to the State-owned Land Use Rights Certificate (Document No.: Ning qi guo yong (2003) Di 07565) dated 29 August 2003 issued by the People's Government of Nanjing City, the land use rights of the property with a site area of approximately 50,117 sq.m. for a term expiring on 17 August 2053 for industrial use have been granted to Party B.
3. According to the Construction and Engineering Planning Permit (Document No.: Ningguichengdongjianzhu (2003) 6535) dated 16 September 2003 issued by Planning Bureau of Nanjing City, the development scale of the property is permitted to comprise a gross floor area of 13,814.45 sq.m..
4. According to the Construction and Engineering Works Commencement Permit (Document No. Ningjianjixu (2004) Di062) dated 19 March 2004 issued by Nanjing City Construction Committee, Party B is permitted to commence the construction of the development comprising a gross floor area of approximately 13,814.45 sq.m..
5. Upon inspection, there are certain items of construction in progress on the site. However, for indicative purpose, the incurred construction cost of these items of construction in progress as at 30 April 2004 was approximately RMB28.3 million and the estimated total construction costs for completion is RMB48,980,000.
6. According to the information provided, Party B, the successor of Sample Computer Technology, is a joint stock limited company established in the PRC on 29 December 2000 under the Company Law.
7. We understand that the current status of titles, grant of major approvals, licences and documents of the property are as follows:

(a)	State-owned Land Use Rights Grant Contract	Yes
(b)	State-owned Land Use Rights Certificate	Yes
(c)	Construction and Engineering Planning Permit	Yes
(d)	Construction and Engineering Works Commencement Permit	Yes
8. The PRC legal opinion states that:
 - (a) The legal title of the granted land use rights of the property is vested in Party B.
 - (b) Party B is entitled to transfer, let or mortgage the land in accordance with the PRC laws.
 - (c) The property is free of mortgage.

VALUATION CERTIFICATE

Property	Description and tenure	Particulars of occupancy	Open market value in existing state as at 30 April 2004
2. Villa B4 Gao Xin Area, Pu Kou District Nanjing City, Jiangsu Province, The PRC	The property comprises a 2- storey house with basement completed in or about 2001. The property has a total gross floor area of approximately 395.49 sq.m.	The property is currently occupied by the Group for office purpose	RMB1,000,000 equivalent to HK\$943,000

Notes:

1. According to the Agreement of Sale and Purchase dated 10 December 2001, Nanjing High Technology and Economic Development Company ("Party A") agreed to sell the property to Nanjing Sample Technology Company Limited ("Party B") at a total consideration of RMB880,000.
2. According to the Building Ownership Certificate dated 19 August 2003 (Document No.: Puzhuan Zi Di 202601) issued by the Real Estate Bureau of Nanjing City, the building ownership of the property is vested in Party B.
3. We understand that the current status of titles, grant of major approvals, licences and documents of the property are as follows:

Building Ownership Certificate	Yes
--------------------------------	-----
4. According to a letter issued by the Real Estate Bureau of Nanjing City on 6 February 2004, the property is permitted for "office" use.
5. According to the information provided, Party B, the successor of Sample Computer Technology, is a joint stock limited company established in the PRC on 29 December 2000 under the Company Law.
6. The PRC Legal Opinion states that:
 - (a) The legal title of the property is vested in Party B.
 - (b) Party B is entitled to transfer, let or mortgage the property in accordance with the PRC laws.
 - (c) The property is free of mortgage.

VALUATION CERTIFICATE

Group II – Property interests rented and occupied by the Group in the PRC

Property	Description	Particulars of occupancy	Open market value in existing state as at 30 April 2004
3. Room 702-I, Level 7, Block No. 54, Cheng Chang Development Zone, Jiangsu Software Park, No. 168 Longpan Zhong Road, Nanjing City, Jiangsu Province, The PRC	The property comprises portion on level 7 of a 10-storey building completed in 2000. The property has a gross floor area of approximately 1,088 sq.m..	The property is rented by an independent third party to Nanjing Sample Technology Company Limited under the lease agreement dated 14 November 2003 for a term from 15 November 2003 to 14 November 2004 at a semi-annual rent of RMB221,952 and management fee of RMB26,112. The property is currently occupied by the Group for software development use.	No commercial value

Notes:

1. According to the lease registration certificate (Document No.: Ningfangchangchengzu Zi Di 230102) dated 15 November 2003, the permitted use of the property is "office" use.
2. The landlord is an independent third party, who is not connected with and is independent of any of the directors, chief executives or shareholders of the Group or of any of its subsidiaries or any of their respective associates.
3. According to the information provided, Nanjing Sample Technology Company Limited, the successor of Sample Computer Technology, is a joint stock limited company established in the PRC on 29 December 2000 under the Company Law.
4. The PRC Legal Opinion states that:
 - (a) the lease agreement is legally valid and binding.
 - (b) the lease agreement is duly registered.

VALUATION CERTIFICATE

Property	Description	Particulars of occupancy	Open market value in existing state as at 30 April 2004
4. Room 702-2, Level 7, Block No. 54, Cheng Chang Development Zone, Jiangsu Software Park, No. 168 Longpan Zhong Road, Nanjing City, Jiangsu Province, The PRC	The property comprises portion on level 7 of a 10-storey building completed in 2000. The property has a gross floor area of approximately 150 sq.m..	The property is rented by an independent third party to Nanjing Golden Dragon Software Company Limited under the lease agreement dated 14 November 2003 for a term from 15 November 2003 to 14 November 2004 at a semi-annual rent of RMB30,600 and management fee of RMB3,600. The property is currently occupied by the Group for software development use.	No commercial value

Notes:

1. According to the lease registration certificate (Document No.: Zi Di 230104) dated 15 November 2003, the permitted use of the property is "office" use.
2. The landlord is an independent third party, who is not connected with and is independent of any of the directors, chief executives or shareholders of the Group or of any of its subsidiaries or any of their respective associates.
3. According to the information provided, Nanjing Golden Dragon Software Company Limited, a limited liability Company established in the PRC on 7 November 2001, is owned as to 95% by Nanjing Sample Technology Company Limited and 5% by Qi Tong Lin (祁同林).
4. The PRC Legal Opinion states that:
 - (a) the lease agreement is legally valid and binding.
 - (b) the lease agreement is duly registered.

VALUATION CERTIFICATE

Property	Description	Particulars of occupancy	Open market value in existing state as at 30 April 2004
5. Room 702-3, Level 7, Block No. 54, Cheng Chang Development Zone, Jiangsu Software Park, No. 168 Longpan Zhong Road, Nanjing City, Jiangsu Province, The PRC	The property comprises portion on level 7 of a 10-storey building completed in 2000. The property has a gross floor area of approximately 150 sq.m..	The property is rented by an independent third party to Nanjing Sample Information System Engineering Company Limited under the lease agreement dated 14 November 2003 for a term from 15 November 2003 to 14 November 2004 at a semi-annual rent of RMB30,600 and management fee of RMB3,600. The property is currently occupied by the Group for software development use.	No commercial value

Notes:

1. According to the lease registration certificate (Document No.: Ningfangchangchengju Zi Di 230101) dated 15 November 2003, the permitted use of the property is "office" use.
2. The landlord is an independent third party, who is not connected with and is independent of any of the directors, chief executives or shareholders of the Group or of any of its subsidiaries or any of their respective associates.
3. According to the information provided, Nanjing Sample Information System Engineering Company Limited, a limited liability company established in the PRC on 11 March 2000, is owned as to 80% by Nanjing Sample Technology Company Limited and 20% by Nanjing Sample Technology Group Company Limited.
4. The PRC Legal Opinion states that:
 - (a) the lease agreement is legally valid and binding.
 - (b) the lease agreement is duly registered.

VALUATION CERTIFICATE

Property	Description	Particulars of occupancy	Open market value in existing state as at 30 April 2004
6. Room 701-3, Level 7, Block No. 54, Cheng Chang Development Zone, Jiangsu Software Park, No. 168 Longpan Zhong Road, Nanjing City, Jiangsu Province, The PRC	The property comprises portion on level 7 of a 10-storey industrial building completed in 2000. The property has a gross floor area of approximately 270 sq.m..	The property is rented to Nanjing Sample Technology Company Limited by an independent third party under the lease agreement dated 5 January 2004 for a term from 15 January 2004 to 31 May 2004 at the total rent of RMB41,310 and management fee of RMB4,860. The property is currently occupied by the Group for software development.	No commercial value

Notes:

1. According to the lease registration certificate (Document No.: Ningfangchangchengju Zi Di 230102) dated 15 November 2003, the permitted use of the property is "office" use.
2. The landlord is an independent third party, who is not connected with and is independent of any of the directors, chief executives or shareholders of the Group or of any of its subsidiaries or any of their respective associates.
3. According to the information provided, Nanjing Sample Technology Company Limited, the successor of Sample Computer Technology, is a joint stock limited company established in the PRC on 29 December 2000 under the Company Law.
4. The PRC Legal Opinion states that:
 - (a) the leased agreement is legally valid and binding.
 - (b) the lease agreement is duly registered.
5. The tenancy of the property has been renewed under a tenancy agreement dated 24 May 2004 for a term of half a year commencing from 1 June 2004 to 31 December 2004 at a semi-annual rent of RMB55,080 and management fee of RMB6,480.

TAXATION OF SECURITY HOLDERS

The following is a summary of certain PRC and Hong Kong tax consequences of the ownership of H Shares by an investor that purchases such H Shares in connection with the Placing and holds the H Shares as capital assets. This summary does not purport to address all material tax consequences of the ownership of H Shares, and does not take into account the specific circumstances of any particular investors such as tax-exempt entities, certain insurance companies, maker-dealer, investors liable for alternative minimum tax, investors that actually or constructively own 10% or more of the voting shares of the Company, investors that hold H Shares as part of a straddle or a hedging or conversion transaction whose functional currency is not the US dollars, some of which may be subject to special rules. This summary is based on the tax laws of the PRC and Hong Kong as in effect on the date hereof which are subject to change for changes in interpretations, possibly with retroactive effect.

The discussion does not address any aspects of Hong Kong or PRC taxation other than income taxation, capital taxation, stamp taxation and estate taxation. Prospective investors are urged to consult their tax advisers regarding the PRC, Hong Kong and other tax consequences of owning and disposing of H Shares.

Taxation of dividends

PRC taxation

Individual investors. According to the individual Income Tax Law of the PRC, as amended on 31 October 1993 and effective 1 January 1994, and amended on 30 August 1999 and effective on the same date, respectively, dividends paid by PRC companies are ordinarily subject to a PRC withholding tax levied at a flat rate of 20%. For a foreign individual who is not a resident of the PRC, the receipt of dividends from a company in the PRC is normally subject to a withholding tax of 20%, unless reduced by an applicable tax treaty. However, the PRC State Administration of Taxation (國家稅務總局) (the "SAT", the PRC central government tax authority which succeeded the State Tax Bureau issued, on 21 July 1993, the Notice of the PRC State Administration of Taxation Concerning the Taxation of Gains on Transfer of and Dividends from Shares (Equities) Received by Foreign Investment Enterprises, Foreign Enterprises and Foreign Individuals (《關於外商投資企業、外國企業和外籍個人取得股票(股權)轉讓收益和股息所得稅收問題的通知》國稅發[1993]045號) ("Tax Notice") which states that dividends paid by a PRC company to individuals with respect to shares listed on an overseas stock exchange ("Overseas Shares"), such as the H Shares, are not subject to PRC withholding tax. The relevant tax authority has not collected withholding tax on dividend payments on Overseas Shares.

The Amendments to the Individual Income Tax Law of the PRC (關於修改《中華人民共和國個人所得稅法》的決定) (the "Amendments") were promulgated on 31 October 1993 and became effective on 1 January 1994. The Amendments state that they shall supersede the provisions of any contradictory prior administrative regulations concerning individual income tax. Pursuant to the requirements of the Amendments and the amended Individual Income Tax Law (《國稅總局關於外籍個人持有中國境內上市公司股票所得的股息、有關稅收問題的函》國稅函發[1994]440號), foreign individuals are subject to withholding tax on dividends paid by a PRC company at a rate of 20% unless specifically exempted by the tax authority of the State Council. However, in a letter dated 26 July 1994 to the State Economic Restructuring Commission, the Securities Commission and CSRC, the SAT reiterated the temporary tax exemption stated in the Tax Notice for dividends received from a PRC company listed overseas. In the event that this letter is withdrawn, a 20% tax may be withheld on dividends in accordance with the Amendments and the Individual Income Tax Law. Such withholding tax may be reduced pursuant to an applicable double taxation treaty.

Enterprises. According to the Income Tax Law of the PRC Concerning Foreign Investment Enterprises and Foreign Enterprises (中國外商投資企業及外國企業所得稅法), dividends paid by PRC companies (other than Foreign Investment Enterprises) to foreign enterprises with no permanent establishment in the PRC are ordinarily subject to a PRC, withholding tax levied at a flat rate of 20%. However, according to the Tax Notice, a foreign enterprise with no permanent establishment in the PRC receiving dividends paid with respect to a PRC company's Overseas Shares will temporarily not be subject to the 20% withholding tax. If such withholding tax becomes applicable in the future, the rate could be reduced pursuant to an applicable double taxation treaty.

Tax treaties. Investors who do not reside in the PRC and reside in countries which have entered into double-taxation relief treaties with the PRC may be entitled to a reduction of the withholding tax imposed on the payment of dividends to investors of the Company who do not reside in the PRC. The PRC currently has double-taxation relief treaties with a number of other countries, which include Australia, Canada, France, Germany, Japan, Malaysia, the Netherlands, Singapore, the United Kingdom and the United States.

Hong Kong Taxation

No tax will be payable in Hong Kong in respect of dividends paid by the Company.

Taxation of capital gains

PRC taxation

The Tax Notice provides that gains realised by foreign enterprises that are holders of Overseas Shares (which would include the H Shares) would, temporarily, not be subject to capital gains taxes. As to individual holders of Overseas Shares, the Provisions for Implementation of Individual Income Tax Law of the PRC (中國個人所得稅法實施條例) (the "Provisions"), issued on 28 January 1994, stipulated that gains realised on the sale of equity shares would be subject to income tax at a rate of 20%. The Provisions empower the MOF to draft detailed tax rules on the mechanism for collecting such tax, which shall be implemented upon approval by the State Council. However, no income tax on gains realised on sale of equity shares has been collected. Gains on the sale of shares by individuals were temporarily exempted from individual income tax pursuant to notices issued by the MOF and the SAT dated 20 June 1994, 9 February 1996 and 30 March 1998, respectively. In the event such temporary exemption is withdrawn or ceases to be effective, individual holders of H Shares may be subject to capital gains tax at the rate of 20% unless such tax is reduced or eliminated by an applicable double taxation relief treaty.

Hong Kong Taxation

No tax is imposed in Hong Kong in respect of capital gains from the sale of property (such as the H Shares). Trading gains from the sale of property (such as the H Shares) by persons carrying on a business in Hong Kong, where such gains are derived from or arisen in Hong Kong from such business, will be chargeable to Hong Kong profits tax which is currently imposed at the rate of 17.5% on corporations and at a maximum rate of 16% on individuals. Gains from sales of the H Shares effected on the Stock Exchange will be considered to be derived from or to have arisen in Hong Kong. Liability for Hong Kong profits tax would thus arise in respect of trading gains from sales of H Shares realised by persons carrying on a business of trading or dealing in securities in Hong Kong.

TAXATION OF THE COMPANY IN HONG KONG

The Directors do not consider that any of the income of the Company is derived from or arises in Hong Kong for the purpose of Hong Kong profits tax. The Company will, therefore, not be subject to Hong Kong profits tax.

Additional Hong Kong tax considerations*Stamp duty*

Hong Kong stamp duty will be payable by the purchaser on every purchase and by the seller on every sale of H Shares. The duty is charged at the ad valorem rate of HK\$1 per HK\$1,000 or part thereof of the consideration for, or (if greater) the value of, the H Shares transferred (i.e. a total of HK\$2 per HK\$1,000 or part thereof is currently payable on a typical sale and purchase transaction of H Shares). In addition, a fixed duty of HK\$5 is currently payable on an instrument of transfer of H Shares. Where one of the parties is a resident outside Hong Kong and does not pay the ad valorem duty due by it, the duty not paid will be assessed on the instrument of transfer (if any) and will be payable by the transferee.

Estate duty

Estate duty is imposed upon the principal value of property situated in Hong Kong passing on the death of a person. H Shares are regarded as property situated in Hong Kong for estate duty purposes. Hong Kong estate duty is imposed on the principal value of a deceased's estate at graduated rates from 5% to 15%. In respect of the estate of persons dying on or after 1 April 1998, no estate duty is payable where the principal value of the dutiable estate does not exceed HK\$7.5 million; the maximum rate of 15% applies where the principal value of the dutiable estate exceeds HK\$10.5 million.

TAXATION OF THE COMPANY IN THE PRC**Income tax**

With effect from 1 January 1994, income tax payable by PRC domestic enterprises is governed by the PRC Enterprise Income Tax Provisional Regulations (中國企業所得稅暫行條例) (“EIT Regulations”). The EIT Regulations provide for an income tax rate of 33% unless a lower rate is provided by law, administrative regulations or State Council regulations.

Since the Company is based and having all of its operations in the PRC, the Company is only subject to the PRC corporate income taxes, for the Relevant Periods. The current applicable rate of income tax of the Company is 15%. Pursuant to the Notice of Preferential Policy in Relation to Enterprise Income Tax (《關於企業所得稅若干優惠政策的通知》(94)財稅字第001號) jointly issued by the MOF and State Administration of Taxation, enterprises registered within the high and new technology industry development zones approved by the State Council may enjoy rebated 15% income tax rate in income tax payment if they are recognised and authorised as high-tech enterprises by the relevant authorities. The Company, with the registered office in the Nanjing High and New Technology Industry Development Zone, one of the national high and new technology industry development zones approved by the State Council, is a company that has been recognised and conferred the title of High and New Technology Enterprise by the Department of Science and Technology of Jiangsu province, and hence remits income tax based on this preferential 15% tax rate.

Business tax

Pursuant to the Provisional Regulations of the PRC Concerning Business Tax (中國營業稅暫行條例), effective from 1 January 1994 and the implementing rules, business tax is imposed on enterprises which provide taxable services, transfer intangible property or sell real estate in the PRC. The business tax is levied at a rate from 3% to 5% on the provision of taxable services, transfer of intangible property or sale of real estate in the PRC.

Additional PRC tax considerations*PRC stamp tax*

PRC stamp tax is imposed on the transfer of shares in PRC companies that are publicly-traded under the Provisional Regulations Concerning Questions of Taxation on Enterprises Experimenting with the Share System (股份制試點企業有關稅收問題的暫行規定). However, such stamp tax should not apply to the acquisition or disposal by non-PRC investors of H Shares outside the PRC by virtue of the Provisional Regulations which became effective on 1 October 1988. The Provisional Regulations provide that PRC stamp tax is imposed only on documents executed or received within the PRC which are legally binding in the PRC and are protected under the PRC laws.

Estate tax

Currently, no liability for Estate Tax under PRC law and regulations will arise from non-PRC nationals holding H shares.

FOREIGN EXCHANGE

The lawful currency of the PRC is the Renminbi, which is subject to foreign exchange control and is not freely convertible into foreign exchange at this time. The SAFE, under the authority of the PBOC, is empowered to administer all matters relating to foreign exchange, including the enforcement of foreign exchange control regulations.

Prior to 31 December 1993, a quota system was used for the management of foreign currency. Any enterprise requiring foreign currency was required to obtain a quota from the local SAFE office before it could convert Renminbi into foreign currency through the PBOC or other designated banks. Such conversion had to be effected at the official rate prescribed by the SAFE on a daily basis. Renminbi could also be converted into foreign currency at swap centres. The exchange rates used by swap centres were largely determined by the demand for, and supply of, foreign currencies and the Renminbi requirements of enterprises in the PRC. Any enterprise that wished to buy or sell foreign currency at a swap centre first had to obtain the approval of the SAFE.

On 28 December 1993, the PBOC, under the authority of the State Council, promulgated the Notice Concerning Further Reform of the Foreign Currency Control System (外匯管理體制) (the "Notice"), effective from 1 January 1994. The Notice announced the abolition of the system of foreign exchange quotas, the implementation of conditional convertibility of Renminbi in current account items, the establishment of the system of settlement and payment of foreign exchange by banks, and the unification of the official Renminbi exchange rate and the market rate for Renminbi established at swap centres. On 26 March 1994, PBOC promulgated the "Provisional Regulations for the Administration of Settlement, Sale and Payment of Foreign Exchange" (the "Provisional Regulations"). The Provisional Regulations set out detailed provisions regulating the sale and purchase of foreign exchange by enterprises, economic organisations and social organisations in the PRC.

On 29 January 1996, the State Council promulgated the Regulations on the Control of Foreign Exchange of the People's Republic of China (中華人民共和國外匯管理條例) (the "Control of Foreign Exchange Regulations") which became effective from 1 April 1996. The Control of Foreign Exchange Regulations classified all international payments and transfers into current account items and capital account items. Current account items are no longer subject to SAEC approval while capital account items still are. The Control of Foreign Exchange Regulations were subsequently amended on 14 January 1997. This latest amendment affirmatively states that the State shall not restrict international current account payments and transfers.

On 20 June 1996, the PBOC promulgated the Regulations for Administration of Settlement, Sale and Payment of Foreign Exchange (結匯、售匯及付匯管理規定) (the "Settlement Regulations") which took effect on 1 July 1996. The Settlement Regulations superseded the Provisional Regulations and abolished the remaining restrictions on convertibility of foreign exchange in respect of current account items while retaining the existing restrictions on foreign exchange transactions in respect of capital account items. On the basis of the Settlement Regulations, the PBOC also published the Announcement on the Implementation of Foreign Exchange Settlement and Sales at Banks by Foreign-invested Enterprises (中國人民銀行關於對外商投資企業實行銀行結售匯的公告) (the "Announcement"). The Announcement permits foreign-invested enterprises to open, on the basis of their needs, foreign exchange settlement accounts for current account receipts and payments of foreign exchange along with specialised accounts for capital account receipts and payments at designated foreign exchange banks.

On 25 October 1998, the PBOC and the SAFE promulgated the Notice Concerning the Discontinuance of Foreign Exchange Swapping Business (關於停辦外匯調劑業務的通知), pursuant to which and with effect from 1 December 1998, all foreign exchange swapping business in the PRC for foreign-invested enterprises shall be discontinued, while the trading of foreign exchange by foreign-invested enterprise shall come under the banking system for the settlement and sale of foreign exchange.

Since 1 January 1994, the former dual exchange rate system for Renminbi has been abolished and replaced by a managed floating exchange rate system, which is determined by demand and supply. The PBOC sets and publishes daily the Renminbi-US dollar base exchange rate. This exchange rate is determined with reference to the transaction price for Renminbi-US dollars in the inter-bank foreign exchange market on the previous day. The PBOC will also, with reference to exchange rates in the international foreign exchange market, announce the exchange rates of Renminbi against other major foreign currencies. In foreign exchange transactions, designated foreign exchange banks may, within a specified range, freely determine the applicable exchange rate in accordance with the exchange rate announced by the PBOC.

Save for foreign-invested enterprises or other enterprises which are specially exempted by relevant regulations, all entities in China (with the exception of certain foreign trade companies and production-type enterprises with import-export operation right, which may be permitted to retain a certain amount of their foreign exchange income from their current account transactions and to use such monies to make foreign exchange payments for their current account transactions and permitted capital account transactions) must sell their foreign exchange income to designated foreign exchange banks. Foreign exchange income from loans issued by organisations outside the territory or from the issuance of bonds and shares (for example, foreign exchange income received by the Company from the sale of shares overseas) is not required to be sold to designated foreign exchange banks, but may be deposited in foreign exchange accounts at the designated foreign exchange banks.

Chinese enterprises (including foreign-invested enterprises) which require foreign exchange for transactions relating to current account items, may, without the approval of SAFE effect payment from their foreign exchange account or convert and pay at the designated foreign exchange banks, on the strength of valid receipts and proof. Foreign-invested enterprises which need foreign exchange for the distribution of profits to their shareholders, and Chinese enterprises which in accordance with regulations are required to pay dividends to shareholders in foreign exchange (like the Company), may on the strength of board resolutions on the distribution of profits and other relevant documents required effect payment from their foreign exchange account or convert and pay at the designated foreign exchange banks.

Convertibility of foreign exchange in respect of capital account items, like direct investment and capital contribution, is still subject to restriction, and prior approval from SAFE and the relevant branch must be sought.

Dividends to holders of H Shares are declared in Renminbi but are required to be paid in Hong Kong dollars.

This Appendix sets out summaries of PRC company and securities regulations, certain material differences between the Company Law and Hong Kong company law, additional regulatory provisions introduced by the Hong Kong Stock Exchange in relation to PRC joint stock limited companies and the Articles of Association. The main objective is to provide investors with an overview of the rights and obligations of shareholders of the Company and the principal legal and regulatory provisions applicable to the Company.

I. PRC LEGAL AND REGULATORY PROVISIONS

(I) Company Law

On 29 December 1993, the Standing Committee of the Eighth NPC adopted the Company Law which came into effect on 1 July 1994 and was amended on 25 December 1999. Companies established under laws, administrative regulations, local laws and the Standard Opinion for Limited Liability Companies, and the Standard Opinion for Joint Stock Limited Companies formulated by the relevant departments of the State Council before the implementation of the Company Law will not be affected by the Company Law and shall continue to be recognised. Those companies which have not wholly complied with the provisions of the Company Law shall comply with the relevant requirements within a specified period of time. The State Council may separately promulgate detailed implementing measures.

Set out below is a summary of the major provisions of the Company Law, the Special Regulations and the Mandatory Provisions. On 4 July 1994, the Special Regulations were passed at the Second Standing Committee Meeting of the State Council, and they were promulgated and implemented on 4 August 1994. The Special Regulations are formulated according to the provisions of Sections 85 and 155 of the Company Law in respect of the overseas share subscription and listing of joint stock limited companies. The Mandatory Provisions were issued jointly by the Securities Commission and the State Economic Restructuring Commission on 27 August 1994, prescribing provisions which must be incorporated into the articles of association of joint stock limited companies to be listed overseas. Accordingly, the Mandatory Provisions have been incorporated in the Articles of Association (which are summarised in this Appendix VI). References to a “company” are to a joint stock limited company established under the Company Law with overseas listed foreign invested shares.

Copies of the Chinese text of the Company Law, Special Regulations and the Mandatory Provisions together with copies of an unofficial English translations thereof are available for inspection as mentioned in the paragraph headed “Documents available for inspection” in Appendix VIII to this prospectus.

General

A “joint stock limited company” is a corporate legal person incorporated under the Company Law, whose registered capital is divided into shares of equal par value. The liability of its shareholders is limited to the extent of the Shares held by them, and the liability of the company is limited to the full amount of all the assets owned by it.

A State-owned enterprise that is restructured into a company must comply with the conditions and requirements specified by law and administrative regulations, for the modification of its operation mechanisms, the systematic handling and evaluation of the company’s assets and liabilities and the establishment of internal management organs.

A company must conduct its business in accordance with the laws and professional ethics, promote the concept of a socialist market economy and be subject to the supervision of the government and the general public.

A company may invest in other limited liability companies and joint stock companies and the company's liabilities with respect to such invested companies are limited to the amount invested. However, apart from investment companies and holding companies specified by the State Council, the amount of a company's aggregate investment in other companies may not exceed 50% of its net assets.

Incorporation

A company may be incorporated by promotion or public subscription.

A company may be incorporated by a minimum of five promoters, but at least half of the promoters must reside within the PRC. According to the Special Regulations, State-owned enterprises or enterprises with the majority of their assets owned by the PRC government can be restructured in accordance with the relevant regulations to become joint stock limited companies which may issue shares to overseas investors. These companies if incorporated by public subscription may have less than five subscribers and can issue new shares once incorporated.

Companies incorporated by promotion are companies the entire registered capital of which is subscribed for by the promoters. Where companies are incorporated by public subscription, not less than 35% of their total shares must be subscribed for by the promoters and the remainder of their shares shall be offered to the public.

The registered capital of a company is the amount of its total paid up capital as registered with the relevant administration for industry and commerce. The minimum registered capital of a company is RMB10 million. The total capital of a company which proposes to apply for its shares to be listed on a stock exchange must not be less than RMB50 million.

The establishment of a company must be approved by the department authorised by the State Council or by the provincial level people's government.

The promoters shall convene an inaugural meeting within 30 days after the issued shares have been fully paid up, and shall give notice to all subscribers or make an announcement of the date of the inaugural meeting 15 days before the meeting. The inaugural meeting may be convened only with the presence of shareholders holding shares representing more than 50% of the voting rights in the company. At the inaugural meeting, matters including the adoption of draft articles of association proposed by the promoter(s) and the election of the board of directors and the supervisory committee of the company will be dealt with. All resolutions of the meeting require the approval of subscribers with at least half of the voting rights present at the meeting.

Within 30 days after the conclusion of the inaugural meeting, the board of directors shall apply to the registration authority for registration of the establishment of the company. A company is formally established and has the status of a legal person after the approval of registration had been given by the relevant administration for industry and commerce and a business licence has been issued. Companies established by the public subscription method shall file a report on the offer of shares with the securities administration department of the State Council for record.

A company's promoters shall individually and collectively be liable for: (i) the payment of all expenses and liabilities incurred in the incorporation process if the company cannot be incorporated; (ii) the repayment of subscription monies to the subscribers together with interest at bank rates for a deposit of the same term if the company cannot be incorporated; and (iii) damages suffered by the company as a result of the default of the promoters in the course of incorporation of the company. According to the Provisional Regulations Concerning the Issue and Trading of Shares promulgated by the State Council on 22 April 1993 (which is only applicable to issue and trading of shares in the PRC and their related activities), if a company is established by means of subscription, the promoters of such company are required to assume joint responsibility for the accuracy of the contents of the prospectus and to ensure that the prospectus does not contain any misleading statement or omit any material information.

Share capital

The promoters may make capital contribution in cash, or in kind or by way of injection of assets, industrial property rights, non-patented technology or land use rights based on their appraised value. The amount of investment made in the form of industrial property rights and non-patented technology may not exceed 20% of the registered capital of the company.

If a capital contribution is made other than in cash, a valuation and verification of the property contributed must be carried out and converted into shares.

A company may issue registered or bearer share certificates. However, shares issued to promoters, state-authorised investment organisations and PRC legal persons shall be in the form of registered share certificates, and may not be registered under a different name or in the name of an agent.

The Special Regulations and the Mandatory Provisions provide that shares issued to foreign investors and listed overseas be issued in registered form and shall be denominated in Renminbi and subscribed for in foreign currency.

Under the Special Regulations and the Mandatory Provisions, shares issued to foreign investors and investors from the territories of Hong Kong, Macau and Taiwan and listed overseas are known as overseas listed foreign invested shares, and those shares issued to investors within the PRC other than the territories specified above are known as domestic invested shares.

A company may offer its shares to the public overseas with approval by the securities administration department of the State Council. Specific measures shall be specifically formulated by the State Council. Under the Special Regulations, upon approval of the CSRC, a company may agree, in the underwriting agreement in respect of an issue of overseas listed foreign invested shares, to retain not more than 15% of the aggregate number of overseas listed foreign invested shares proposed to be issued after accounting for the number of underwritten shares.

The share offering price may be equal to or greater than the par value, but may not be less than par value.

The transfer by a shareholder of its shares must be carried out through a lawfully established stock exchange. Transfer of registered shares by a shareholder must be made by means of an endorsement or by other means stipulated by a law or by administrative regulations. Bearer share certificates are transferred by delivery of the certificates to the transferee.

Shares held by a promoter of a company may not be transferred for three years after the company's establishment. Directors, supervisors and the manager of a company shall not transfer the shares they hold in the company during their term of office. There is no restriction under the Company Law as to the percentage of shareholding a single shareholder may hold in a company. However, according to the Provisional Regulations Concerning the Issue and Trading of Shares, a PRC individual shareholder cannot own more than 0.5% of the outstanding domestically issued common shares of a listed company.

Transfers of shares may not be entered in the register of shareholders within 30 days before the date of a shareholders' meeting or within five days before the record date set for the purpose of distribution of dividends.

Increase in capital

Under the Company Law, an increase in capital in a company by means of an issue of new shares must be approved by shareholders in general meeting and meet the following conditions:

- (i) the previous issue of shares has been fully subscribed for and at least one year has elapsed since that issue, but under the Special Regulations, if a company increases its capital for the issue of overseas listed foreign invested shares, the time period elapsed since the last issue of shares may be less than 12 months;
- (ii) the company has been profitable for the last three consecutive years and is able to make dividend payments to its shareholders;
- (iii) there has been no false reporting in the company's financial and accounting documents during the last three years; and
- (iv) the company's expected profit rate is comparable to the bank deposit rate for the same term.

Once the shareholders in general meeting have passed a resolution to issue new shares, the board of directors must apply to the authorised department of the State Council or to the provincial level people's government for approval. Public offers require the approval of the securities administration department of the State Council.

After payment in full for the new shares issued, a company must change its registration with the relevant administration for industry and commerce and issue a public notice accordingly.

Reduction of share capital

Subject to the minimum registered capital requirements, a company may reduce its registered capital in accordance with the following procedures prescribed by the Company Law:

- (i) the company shall prepare a balance sheet and an inventory of the assets;
- (ii) the reduction of registered capital must be approved by shareholders in general meeting;

- (iii) the company shall inform its creditors of the reduction in capital within 10 days and publish an announcement of the reduction in the newspaper at least three times within 30 days after the resolution approving the reduction has been passed;
- (iv) the creditors of the company may within the statutory prescribed time limit require the company to pay its debts or provide guarantees covering the debts within 30 days from the date the creditor receives the notice or where the notice has not been received, within 90 days after the date on which the public announcement is made; and
- (v) the company must apply to the relevant administration for industry and commerce for registration of the reduction in registered capital.

Repurchase of shares

A company may not purchase its own shares other than for the purpose of reducing its capital by cancelling its shares or merging with another company holding its shares or such other purposes permitted by law and administrative regulations. The Mandatory Provisions provide that upon obtaining approvals in accordance with the articles of association of the company and from the relevant supervisory authorities, a company may repurchase its issued shares for the foregoing purposes by way of a general offer to its shareholders or purchase on a stock exchange or an off-market contract.

Under the Company Law, within 10 days following the purchase of a company's own shares, a company must in accordance with applicable law and administrative regulations, cancel that portion of its shares, change its registration and issue a public notice.

Transfer of shares

Shares may be transferred in accordance with the relevant laws and regulations.

A shareholder may only effect a transfer of its shares on a stock exchange established in accordance with law. Registered shares may be transferred after the shareholders endorse their signatures on the back of the share certificates or in any other manner specified by applicable laws and regulations.

Shares issued to promoters may not be transferred within three years after the establishment of the company. Shares held by directors, supervisors and the manager of a company may not be transferred during their term of office with the company and shall declare their shareholdings to the Company.

There is no restriction under the Company Law as to the percentage shareholding of a single shareholder of a company.

Shareholders

Shareholders have such rights and obligations as set down in the articles of association of the company. The articles of association of a company are binding on each shareholder.

Under the Company Law, the rights of a shareholder include:

- (i) to attend in person or appoint a proxy to attend shareholders' general meetings, and to vote in respect of the number of shares held;
- (ii) to transfer his shares at a legally established stock exchange in accordance with the Company Law and the articles of association of the company;
- (iii) to inspect the company's articles of association, minutes of shareholders' general meetings and financial and accounting reports and to make proposals or enquiries in respect of the company's operations;
- (iv) if a resolution adopted by a shareholders' general meeting or the board of directors violates any law or administrative regulations or infringes the lawful rights and interests of shareholders, to institute an action in the People's Court demanding that the illegal infringing action be stopped;
- (v) to receive dividends in respect of the number of shares held;
- (vi) to receive surplus assets of the company upon its termination in proportion to his or her shareholding; and
- (vii) any other shareholders' rights specified in the company's articles of association.

The obligations of a shareholder include the obligation to abide by the company's articles of association, to pay the subscription monies in respect of the shares subscribed for, to be liable for the company's debts and liabilities to the extent of the amount of subscription monies agreed to be paid in respect of the shares taken up by him and any other shareholders' obligation specified in the company's articles of association.

General meetings

The shareholders' general meeting is the organ of authority of the company, which exercises its powers in accordance with the Company Law.

The shareholders' general meeting exercises the following powers:

- (i) to decide on the company's operational policies and investment plans;
- (ii) to elect or remove the directors and decide on matters relating to the remuneration of directors;
- (iii) to elect or remove the supervisors who are representatives of shareholders and decide on matters relating to the remuneration of supervisors;

- (iv) to examine and approve reports of the board of directors;
- (v) to examine and approve reports of the supervisory committee;
- (vi) to examine and approve the company's proposed annual financial budget and final accounts;
- (vii) to examine and approve the company's proposals for profit distribution and for recovery of losses;
- (viii) to decide on any increase or reduction in the company's registered capital;
- (ix) to decide on the issue of bonds by the company;
- (x) to decide on issues such as merger, division, dissolution and liquidation of the company and other matters; and
- (xi) to amend the articles of association of the company.

Shareholders' annual general meeting is required to be held once every year. An extraordinary shareholders' general meeting is required to be held within two months after the occurrence of any of the following circumstances:

- (i) the number of directors is less than the number provided for in the Company Law or less than two-thirds of the number specified in the company's articles of association;
- (ii) the aggregate losses of the company which are not made up reach one-third of the company's total share capital;
- (iii) a request by shareholders holding 10% or more of the company's shares;
- (iv) when deemed necessary by the board of directors; or
- (v) when the supervisory committee proposes convening it.

Shareholders' general meetings shall be convened by the board of directors, and presided over by the chairman of the board of directors.

Notice of the meeting shall be given to all shareholders 30 days before the meeting under the Company Law and 45 days under the Special Regulations and the Mandatory Provisions, stating the matters to be considered at the meeting. Under the Special Regulations and the Mandatory Provisions, shareholders wishing to attend are required to give to the company written confirmation of their attendance 20 days prior to the meeting. Under the Special Regulations, at an annual general meeting of a company, shareholders holding 5% or more of the voting rights in the company are entitled to propose to the company in writing new resolutions to be considered at that meeting, which if within the powers of a shareholders' general meeting, are required to be added to the agenda of that meeting.

Shareholders present at a shareholders' general meeting have one vote for each share they hold.

Resolutions of the shareholders' general meeting must be adopted by more than half of the votes cast by shareholders present in person (including those represented by proxies) at the meeting, with the exception of matters relating to merger, division or dissolution of a company which must be adopted by shareholders with more than two-thirds of the voting rights held by shareholders present (including those represented by proxies) at the meeting. According to the Mandatory Provisions, the increase or reduction of share capital, the issue of bonds or debentures, and any other matters in respect of which the shareholders by ordinary resolution so decide, must be approved by more than two-thirds of the shareholders present in the general meeting. Amendments to the articles of association of a company must be approved by more than two-thirds of the shareholders present in general meeting.

Shareholders may appoint representatives to attend shareholders' general meetings by a written appointment document stating the scope of exercising the voting rights.

There is no specific provision in the Company Law regarding the number of shareholders constituting a quorum in a shareholders' meeting. However, the Special Regulations and the Mandatory Provisions provide that a company's annual general meeting may be convened when replies to the notice of that meeting from shareholders holding shares representing 50% of the voting rights in the company have been received 20 days before the proposed date, or if that 50% level is not achieved, the company shall within five days of the last day for receipt of the replies notify shareholders by public announcement of the matters to be considered at the meeting and the date and place of the meeting and the annual general meeting may be held thereafter. The Mandatory Provisions require class meetings to be held in the event of a variation or derogation of the class rights of a class. Holders of domestic invested shares and holders of overseas listed foreign invested shares are deemed to be different classes of shareholders for this purpose.

Directors

A company shall have a board of directors, which shall consist of five to nineteen members. Under the Company Law, each term of office of a director shall not exceed three years. A director may serve consecutive terms if re-elected.

Meetings of the board of directors shall be convened at least twice a year. Notice of meeting shall be given to all directors at least 10 days before the meeting. The board of directors may provide for a different method of giving notice and notice period for convening an extraordinary meeting of the board of directors.

Under the Company Law, the board of directors exercises the following powers:

- (i) to convene the shareholders' general meeting and report on its work to the shareholders;
- (ii) to implement the resolutions of the shareholders' general meeting;
- (iii) to decide on the company's business plans and investment plans;
- (iv) to formulate the company's proposed annual financial budget and final accounts;

- (v) to formulate the company's proposals for profit distribution and for recovery of losses;
- (vi) to formulate proposals for the increase or reduction of the company's registered capital and the issue of corporate bonds;
- (vii) to prepare plans for the merger, division or dissolution of the company;
- (viii) to decide on the company's internal management structure;
- (ix) to appoint or dismiss the company's general manager; and based on the general manager's recommendation, to appoint or dismiss deputy general managers and financial officers of the company and to decide on their remuneration; and
- (x) to formulate the company's basic management system.

In addition, the Mandatory Provisions provide that the board is also responsible for formulating the proposals for amendment of the articles of association of a company.

Meetings of the board of directors shall be held only if more than half of the directors are present.

Resolutions of the board of directors require the approval of more than half of all directors.

If a director is unable to attend a board meeting, he may appoint another director by a written power of attorney specifying the scope of the authorisation to attend the meeting on his behalf. If a resolution of the board of directors violates the laws, administrative regulations or the company's articles of association as a result of which the company sustains serious losses, the directors participating in the resolution are liable to compensate the company. However, if it can be proven that a director expressly objected to the resolution when the resolution was voted on, and that such objections were recorded in the minutes of the meeting, such director may be relieved of that liability.

Under the Company Law, the following persons may not serve as a director of a company:

- (i) persons without civil capacity or with restricted civil capacity;
- (ii) persons who have committed the offense of corruption, bribery, taking of property, misappropriation of property or destruction of the social economic order, and have been sentenced to criminal punishment, where less than five years have elapsed since the date of completion of the sentence; or persons who have been deprived of their political rights due to criminal offense, where less than five years have elapsed since the date of the completion of implementation of this deprivation;
- (iii) persons who are former directors, factory managers or managers of a company or enterprise which has become bankrupt and been liquidated due to a mismanagement and who are personally liable for the bankruptcy of such company or enterprise, where less than three years have elapsed since the date of the completion of the bankruptcy and liquidation of the company or enterprise;

- (iv) persons who were legal representatives of a company or enterprise which had its business licence revoked due to violation of the law and who are personally liable, where less than three years have elapsed since the date of the revocation of the business licence;
- (v) persons who have a relatively large amount of debt due and outstanding; or
- (vi) persons who are State civil servants.

Other circumstances under which a person is disqualified from acting as a director of a company are set out in the Mandatory Provisions (which have been incorporated in the Articles of Association, a summary of which is set out in this Appendix).

The board of directors shall appoint a chairman, who is elected with approval of more than half of all the directors. The chairman of the board of directors is the legal representative of the company and exercises, amongst others, the following powers:

- (i) to preside over shareholders' general meetings and convene and preside over meetings of the board of directors;
- (ii) to check on the implementation of the resolutions of the board of directors; and
- (iii) to sign the company's share certificates and bonds.

The Special Regulations provide that a company's directors, supervisors, managers and other officers bear fiduciary duties and the duty to act diligently. They are required to faithfully perform their duties, protect the interests of the company and not to use their positions for their own benefit. The Mandatory Provisions (which have been incorporated into the Articles of Association, a summary of which is set out in this Appendix) contain further elaborations of such duties.

Supervisors

A company shall have a supervisory committee composed of not less than three members. Each term of office of a supervisor is three years and he or she may serve consecutive terms if re-elected.

The supervisory committee is made up of representatives of the shareholders and an appropriate proportion of representatives of the company's staff and workers. Directors, managers and financial officers may not act concurrently as supervisors.

The supervisory committee exercises the following powers:

- (i) to review the company's financial position;
- (ii) to supervise the directors and managers in their performance of their duties and to ascertain whether or not they have violated laws, regulations or the articles of association of the company;
- (iii) when the acts of a director or manager are harmful to the company's interests, to require correction of those acts;

- (iv) to propose the convening of extraordinary shareholders' general meetings; and
- (v) other powers specified in the company's articles of association.

The circumstances under which a person is disqualified from being a director of a company described above apply mutatis mutandis to supervisors of a company.

As mentioned above, the Special Regulations provide that a company's supervisors, among other persons, shall bear fiduciary duties. They are required to faithfully perform their duties, protect the interests of the company and not to use their positions for their own benefit. A supervisor is also required to attend board meetings as a non-voting attendant.

Managers and officers

A company shall have a manager who shall be appointed or removed by the board of directors. The manager is accountable to the board of directors and may exercise the following powers:

- (i) supervise the production, business and administration of the company and arrange for the implementation of resolutions of the board of directors;
- (ii) arrange for the implementation of the company's annual business and investment plans;
- (iii) formulate plans for the establishment of the company's internal management structure;
- (iv) formulate the basic administration system of the company;
- (v) formulate the company's internal rules;
- (vi) recommend the appointment and dismissal of deputy managers and any financial controller and appoint or dismiss other administration officers (other than those required to be appointed or dismissed by the board of directors);
- (vii) attend board meetings as a non-voting attendant; and
- (viii) other powers conferred by the board of directors or the company's articles of association.

The Special Regulations and Mandatory Provisions provide that the other senior management of a company includes the financial controller, secretary of the board of directors and other executives as specified in the articles of association of the company.

The circumstances under which a person is disqualified from being a director of a company described above apply mutatis mutandis to managers and officers of the company.

The articles of association of a company shall have binding effect on the shareholders, directors, supervisors, managers and other senior management of the company. Such persons shall be entitled to exercise their rights, apply for arbitration and issue legal proceedings according to the articles of association of the company. The provisions of the Mandatory Provisions regarding the senior management of a company have been incorporated in the Articles of Association (a summary of which is set out in this Appendix).

Duties of directors, supervisors, managers and officers

A director, supervisor, manager and an officer of a company are required under the Company Law to comply with the relevant laws, regulations and the company's articles of association, carry out their duties honestly and protect the interests of the company. A director, supervisor, manager and an officer of a company is also under a duty of confidentiality to the company and is prohibited from divulging the secret information of the company save as permitted by the relevant laws and regulations or by the shareholders.

A director, supervisor, manager and an officer who contravenes any law, regulation or the company's articles of association in the performance of his duties which results in any loss to the company shall be personally liable to the company.

The Special Regulations and the Mandatory Provisions provide that a director, supervisor, manager and an officer of a company owe fiduciary duties to the company and are required to perform their duties faithfully and to protect the interests of the company and not to make use of their positions in the company for their own benefit.

Finance and accounting

A company shall establish its financial and accounting systems according to laws, administrative regulations and the regulations of the responsible financial department of the State Council and at the end of each financial year prepare a financial report which shall be audited and verified as provided by law.

A company shall deposit its financial statements at the company for the inspection by the shareholders at least 20 days before the convening of the annual general meeting of shareholders. A company established by the public subscription method must publish its financial statements.

When distributing each year's after-tax profits, the company shall set aside 10% of its after-tax profits for the company's statutory common reserve fund (except where the fund has reached 50% of the company's registered capital) and 5% to 10% of its after-tax profit for the company's statutory public welfare fund.

When the company's statutory common reserve fund is not sufficient to make up for the company's losses of the previous year, current year profits shall be used to make good the losses before allocations are set aside for the statutory common reserve fund or the statutory common welfare fund.

The company's statutory common welfare fund is used for the collective welfare of the company's staff and workers.

The shareholders in general meeting may resolve to transfer any amount from the after-tax profit of the company to the discretionary common reserve after transferring the requisite amount to the statutory common reserve fund.

After the company has made good its losses and made allocations to its statutory common reserve fund and statutory common welfare fund, the remaining profits are distributed in proportion to the number of shares held by the shareholders.

The common reserve of a company comprises the statutory common reserve, discretionary common reserve and the capital common reserve.

The capital common reserve of a company is made up of the premium over the nominal value of the shares of the company on issue and other amounts required by the relevant governmental authority to be treated as the capital common reserve.

The common reserve of a company shall be applied for the following purposes:

- (i) to make up the company's losses;
- (ii) to expand the business operations of the company; and
- (iii) to pay up the registered capital of the company by the issue of new shares to shareholders in proportion to their existing shareholdings in the company or by increasing the par value of the shares currently held by the shareholders provided that if the statutory common reserve is converted into registered capital, the balance of the statutory common reserve after such conversion shall not be less than 25% of the registered capital of the company.

Appointment and retirement of auditors

The Special Regulations require a company to employ an independent PRC qualified firm of accountants to audit the company's annual report and review and check other financial reports.

The auditors are to be appointed for a term commencing from the close of an annual general meeting and ending at the close of the next following annual general meeting.

If a company removes or ceases to continue to appoint the auditors, it is required by the Special Regulations to give prior notice to the auditors and the auditors are entitled to make representations before the shareholders in general meeting. The appointment, removal or non re-appointment of auditors shall be decided by the shareholders and shall be registered with the CSRC.

Distribution of profits

The Special Regulations provide that the dividends and other distributions to be paid to holders of overseas listed foreign invested shares shall be declared and calculated in Renminbi and paid in foreign currency. Under the Mandatory Provisions, the payment of foreign currency to shareholders shall be made through a receiving agent.

Amendments to articles of association

Any amendments to the company's articles of association must be made in accordance with the procedures set forth in the company's articles of association. Any amendment of provisions incorporated in the articles of association in accordance with the Mandatory Provisions will only be effective after approval by the companies approval department authorised by the State Council and the CSRC. In relation to matters involving the company's registration, its registration with the companies registration authority must also be changed.

Termination and liquidation

A company may apply for the declaration of insolvency by reason of its inability to pay debts as they fall due. After the People's Court has made a declaration of the company's insolvency, the shareholders, the relevant authorities and the relevant professionals shall form a liquidation committee to conduct the liquidation of the company.

Under the Company Law, a company shall be dissolved in any of the following events:

- (i) the term of its operations set down in the company's articles of association has expired or events of dissolution specified in the company's articles of association have occurred;
- (ii) the shareholders in general meeting have resolved to dissolve the company; or
- (iii) the company is dissolved by reason of its merger or demerger.

Where the company is dissolved in the circumstances described in (i) or (ii) above, a liquidation committee must be established within 15 days. Members of the liquidation committee shall be appointed by the shareholders in the general meeting.

If a liquidation committee is not established within the stipulated period, the company's creditors can apply to the People's Court for its establishment.

The liquidation committee shall notify the company's creditors within 10 days after its establishment, and issue at least 3 public notices in the newspapers within 60 days. A creditor shall lodge his claim with the liquidation committee within 30 days after receiving notification, or within 90 days of the first public notice if he did not receive any notification.

The liquidation committee shall exercise the following powers during the liquidation period:

- (i) to handle the company's assets and to prepare a balance sheet and an inventory of the assets;
- (ii) to notify creditors or issue public notices;
- (iii) to deal with and settle any outstanding business of the company;
- (iv) to pay any tax overdue;
- (v) to settle the company's financial claims and liabilities;
- (vi) to handle the surplus assets of the company after its debts have been paid off; and
- (vii) to represent the company in civil lawsuits.

If the company's assets are sufficient to meet its liabilities, they shall be applied towards the payment of the liquidation expenses, wages owed to the employees and labor insurance expenses, tax overdue and debts of the company. Any surplus assets shall be distributed to the shareholders of the company in proportion to the number of shares held by them.

A company shall not engage in new business operations during the liquidation period.

If the liquidation committee becomes aware that the company does not have sufficient assets to meet its liabilities, it must immediately apply to the People's Court for a declaration for bankruptcy. Following such declaration, the liquidation committee shall hand over all affairs of the liquidation to the People's Court.

Upon completion of the liquidation, the liquidation committee shall submit a liquidation report to the shareholders' general meeting or the relevant supervisory department for verification. Thereafter, the report shall be submitted to the companies registration authority in order to cancel the company's registration, and a public notice of its termination shall be issued.

Members of the liquidation committee are required to discharge their duties honestly and in compliance with relevant laws. A member of the liquidation committee is liable to indemnify the company and its creditors in respect of any loss arising from his wilful or material default.

Overseas listing

The shares of a company shall only be listed overseas after obtaining approval from the securities regulatory authority of the State Council and the listing must be arranged in accordance with procedures specified by the State Council.

According to the Special Regulations, a company's plan to issue overseas listed foreign invested shares and domestic invested shares which has been approved by the CSRC may be implemented by the board of directors of a company by way of separate issues, within 15 months after approval is obtained from CSRC.

Loss of share certificates

A shareholder may apply, in accordance with the relevant provisions set out in the PRC Civil Procedure Law, to a People's Court in the event that share certificates in registered form are either stolen or lost, for a declaration that such certificates will no longer be valid. After such a declaration has been obtained, the shareholder may apply to the company for the issue of replacement certificates.

The Mandatory Provisions provide for a separate procedure regarding loss of H share certificates (which has been incorporated in the Articles of Association, a summary of which is set out in this Appendix).

Suspension and termination of listing

The trading of shares of a company on a stock exchange may be suspended if so decided by the securities administration department of the State Council under one of the following circumstances:

- (i) the registered capital or shareholding distribution no longer comply with the necessary requirements for a listed company;
- (ii) the company failed to make public its financial position in accordance with the requirements or there is false information in the company's financial report;

- (iii) the company has committed a major breach of the law; or
- (iv) the company has incurred losses for each of the preceding three years.

Under the circumstances referred to in (ii) and (iii) above, an investigation has revealed that the consequences are serious, or under the circumstances referred to in (i) and (iv) above, the situation has not been rectified within the time stipulated, the securities administration department of the State Council may decide to terminate the listing of a company's shares.

The securities administration department of the State Council may also terminate the listing of a company's shares in the event that the company resolves to cease operation or is so instructed by its government supervisory body, or the company is declared bankrupt.

Merger and demerger

The merger or demerger of a company is to be decided by the shareholders in general meeting subject to the approval of departments authorised by the State Council or the approval of the provincial government.

Companies may merge through merger by absorption or through the establishment of a newly merged entity. If it merges by absorption, the company which is absorbed shall be dissolved. If it merges by forming a new corporation, both companies will be dissolved.

A merger agreement must be signed in the case of a merger of companies and the relevant companies shall draw up their respective balance sheets and inventory of property. The companies should within 10 days of the resolution of the merger inform their respective creditors and publish a notice to the creditors in newspapers at least 3 times, within 30 days of the resolution to merge. Those creditors who had not received written notice may within 90 days of the first published notice, or within 30 days after receiving written notice, request the company to satisfy any unpaid debt or provide equivalent guarantees in cases of guarantees. Companies unable to repay such debts or provide alternative guarantees will not be allowed to merge. Newly merged entities shall be responsible for the debts and obligations of the companies involved in the merger.

When a company demerges into two companies, their respective assets must be separated and separate financial accounts must be drawn up. When a company's shareholders approve the demerger of the company, the company should notify all its creditors within 10 days of such resolution being passed and advertise the same at least three times in newspapers within 30 days. A creditor may within 30 days after receiving written notice or, a creditor who has not received such notice may within 90 days from the first public advertisement, demand that the company repay any outstanding debts or to provide an appropriate guarantee.

Changes in registerable particulars of the companies caused by merger or demerger must be registered in accordance with applicable laws.

Sino-Foreign Investment Joint Stock Limited Company and Sino-Foreign Joint Venture Law

The Company has not applied and does not intend to apply for the status of a sino-foreign investment joint stock limited company; and the Company is not and does not expect to be subject to the Sino-Foreign Joint Venture Law.

(2) Securities Law and Supervision

Since 1992, the PRC has promulgated a number of regulations in relation to the issue of and trading in securities and disclosure of information.

In October 1992, the State Council established the Securities Commission and the CSRC. The Securities Commission was responsible for coordinating the drafting of securities regulations, formulating securities-related policies, planning the development of securities markets, directing, coordinating and supervising all securities-related institutions in the PRC and administering the CSRC. The CSRC was the regulatory arm of the Securities Commission and was responsible for the drafting of regulatory provisions governing securities markets, supervising securities companies, regulating public offers of securities by PRC companies in the PRC or overseas, regulating the trading of securities, compiling securities-related statistics and undertaking research and analysis. In early 1998, the State Council dissolved the Securities Commission, and the former functions of the Securities Commission were assumed by the CSRC.

On 22 April 1993, the State Council promulgated the Provisional Regulations Concerning the Issue and Trading of Shares. These regulations deal with the application and approval procedures for public offerings of equity securities, trading in equity securities, the acquisition of listed companies, deposit, settlement, and transfer of listed equity securities, the disclosure of information with respect to a listed company, enforcement and penalties and dispute settlement. These regulations specifically provide that separate provisions will be promulgated in relation to the issue of and trading in special Renminbi-denominated shares. However, (i) if a PRC joint stock limited company proposes to issue Renminbi-denominated ordinary shares as well as special Renminbi-denominated shares, it has to comply with these regulations in respect of its issue of Renminbi-denominated ordinary shares; (ii) if a PRC company proposes to placing shares directly or indirectly outside the PRC, it will require the approval of the Securities Commission (currently the CSRC); and (iii) provisions of these regulations in relation to acquisitions of listed companies and disclosure of information are expressed to apply to listed companies in general without being confined to listed companies on any particular stock exchange. Hence it is possible that such provisions may be applicable to joint stock limited companies with shares listed on a stock exchange outside the PRC including, for instance, joint stock limited companies with shares listed on GEM, such as the Company.

On 12 June 1993, pursuant to the Provisional Regulations Concerning the Issue and Trading of Shares, the CSRC promulgated the Implementation Measures (Provisional) on Disclosure of Information. Pursuant to these measures, the CSRC is responsible for supervising the disclosure of information by companies which have offered shares to the public both in the PRC and overseas. These measures contain provisions regarding prospectuses and listing reports to be issued in connection with a public offering of shares in the PRC, publication of interim and final reports and announcement of material transactions or matters by companies which have offered shares to the public. Material transactions or matters are those the occurrence of which may have a material effect on the share price of a company. They include, without limitation, changes to a company's articles of association or registered capital, removal of auditors, mortgage or disposal of major operating assets or writing down the value of such assets where the amount being written down exceeds 30% of the total value of such assets, revocation by a court of any resolution passed by the shareholders or the supervisors of a company and the merger or demerger of a company. These measures also contain disclosure provisions in relation to acquisition of listed companies which supplement the requirements contained in the Provisional Regulations Concerning the Issue and Trading of Shares.

On 2 September 1993, the Securities Commission promulgated the Provisional Measures Prohibiting Fraudulent Conduct relating to Securities. The prohibitions imposed by these measures include the use of insider information in connection with the issue of or trading in securities (insider information being defined

to include undisclosed material information known to any insider, which may affect the market price of securities); the use of funds or information or the abuse of power in creating a false or disorderly market or influencing the market price of securities or inducing investors to make investment decisions without knowledge of actual circumstances; and the making of any statement in connection with the issue of and trading in securities which is false or materially misleading and in respect of which there is any material omission. Penalties imposed for contravening any of the provisions of the measures include fines, confiscation of profits and suspension of trading. In serious cases, criminal liability may be imposed.

On 4 July 1994, the State Council promulgated the PRC Special Regulations on Overseas Offering and Listing of Shares by Joint Stock Limited Companies. These provisions deal mainly with the issue, subscription, trading and declaration of dividends and other distributions of foreign capital stock listed abroad and disclosure of information, articles of association of joint stock limited companies having foreign capital stock listed abroad.

On 25 December 1995, the State Council promulgated the Regulations of the State Council Concerning the Domestic Listed Foreign Shares of Joint Stock Limited Companies. These regulations deal mainly with the issue, subscription and trading of, and declaration of dividends and other distributions on, domestic listed foreign Shares and disclosures of information by joint stock limited companies having domestic listed foreign Shares.

On 29 December 1998, the Standing Committee of the National People's Congress promulgated the Securities Law of the PRC. This is the first national securities law in the PRC and is the fundamental law comprehensively regulating activities such as the issuance and trading of securities in the PRC securities market. The Securities Law became effective on 1 July 1999. The Securities Law is applicable to the issuance and trading in the PRC of shares, company bonds and other securities designated by the State Council according to law. Where the Securities Law does not apply, the provisions of the Company Law and other applicable laws and administrative regulations regarding securities will apply.

On 29 March 1999, the State Economic and Trade Commission and the CSRC promulgated the Opinion on the Further Promotion of the Regular Operation and In-Depth Reform of Companies Listed Overseas, which is aimed at regulating the internal operation and management of PRC companies listed overseas. The Company will be subject to the Opinion upon listing of the H Shares on GEM. The Opinion regulates, amongst others, the appointments and functions of external directors and independent directors in the board of directors; and the appointment and functions of external supervisors and independent supervisors in the supervisory committee.

(3) The Arbitration Law

The Arbitration Law of the PRC (the "Arbitration Law") was promulgated by the Standing Committee of the NPC on 31 August 1994 and came into effect on 1 September 1995. It is applicable to, among other matters, trade disputes involving foreign parties where the parties have entered into a written agreement to refer the matter to arbitration before an arbitration committee constituted in accordance with the Arbitration Law. Under the Arbitration Law, an arbitration committee may, before the promulgation by the PRC Arbitration Association of arbitration regulations, formulate interim arbitration rules in accordance with the Arbitration Law and the PRC Civil Procedure Law. Where the parties have by agreement provided arbitration as a method for dispute resolution, the parties are not permitted to institute legal proceedings in a People's Court except when the arbitration agreement is not valid.

The GEM Listing Rules and the Mandatory Provisions require an arbitration clause to be included in the articles of association of a company listed in Hong Kong and in the case of the GEM Listing Rules, also in a contract between the company and each director and supervisor, to the effect that whenever any dispute or claim arises from any rights or obligations provided in the Articles of Association, the Company Law and other relevant laws and administrative regulations concerning the affairs of a company between (i) a holder of overseas listed foreign shares and the company; (ii) a holder of overseas listed foreign shares and a holder of Domestic Shares, unless otherwise specified in the Articles of Association, such parties shall submit that dispute or claim to arbitration before either the China International Economic and Trade Arbitration Commission (“CIETAC”) or the Hong Kong International Arbitration Centre (HKIAC) for arbitration. If the party seeking arbitration elects to arbitrate the dispute or claim at the HKIAC, then either party may apply to have such arbitration conducted in Shenzhen according to the securities arbitration rules of the HKIAC. CIETAC is an economic and trade affairs arbitration organ in the PRC. Pursuant to the China International Economic and Trade Arbitration Commission Arbitration Rules, effective on 1 October 2000, CIETAC’s jurisdiction covers disputes relating to the Hong Kong Special Administrative Region. CIETAC is located in Beijing with branches in Shenzhen and Shanghai.

Under the Arbitration Law, an arbitral award is final and binding on the parties and if a party fails to comply with an award, the other party to the award may apply to the People’s Court for enforcement. A People’s Court may refuse to enforce an arbitral award made by an arbitration commission if there are certain procedural or membership irregularities or the award exceeds the scope of the arbitration agreement or is outside the jurisdiction of the arbitration commission.

A party seeking to enforce an arbitral award of a foreign affairs arbitration organ of the PRC against a party who or whose property is not within the PRC may apply to a foreign court with jurisdiction over the case for enforcement. Similarly, an arbitral award made by a foreign arbitration body may be recognised and enforced by the PRC courts in accordance with the principles of reciprocity or any international treaty concluded or acceded to by the PRC. The PRC acceded to the New York Convention adopted on 10 June 1958 pursuant to a resolution of the Standing Committee of the NPC passed on 2 December 1986. The New York Convention provides that all arbitral awards made by a state which is a party to the New York Convention shall be recognised and enforced by other parties to the New York Convention subject to their right to refuse enforcement under certain circumstances including where the enforcement of the arbitral award is against the public policy of the state to which the application for enforcement is made. It was declared by the Standing Committee of the NPC simultaneously with the accession of the PRC that (1) the PRC will only recognise and enforce foreign arbitral awards on the principle of reciprocity and (2) the PRC will only apply the New York Convention in disputes considered under PRC laws to be arising from contractual and non-contractual mercantile legal relations. Following the resumption of sovereignty over Hong Kong by the PRC on 1 July 1997, the New York Convention no longer applies to the enforcement of Hong Kong arbitration awards in other parts of the PRC. A Memorandum of Understanding on the arrangement for reciprocal enforcement of arbitral awards between Hong Kong and China has been signed on 21 June 1999. The new arrangement is made in accordance with the spirit of the New York Convention. To meet present day’s needs, it will allow awards made over 100 China arbitral authorities with relevant experience to be enforced in Hong Kong. Under the agreed arrangement, Hong Kong arbitration awards will also be enforceable in China. This new arrangement has been approved by the Hong Kong Legislative Council and the Supreme People’s Court of the PRC and became effective on 1 February 2000.

II. HONG KONG LEGAL AND REGULATORY PROVISIONS

(I) Hong Kong company law and its comparison with the PRC law applicable to a joint stock limited company incorporated under the Company Law

Hong Kong company law is primarily set out in the Companies Ordinance (Chapter 32 of the Laws of Hong Kong) (the “Companies Ordinance”) and supplemented by common law. There are material differences between Hong Kong company law and the PRC law applicable to a joint stock limited company incorporated under the Company Law, to which the Company is and will be subject, particularly in the area of investor protection. Certain material differences between the Company Law and Hong Kong company law are summarised below. This summary, however, is not intended to be an exhaustive comparison. It should also be noted that the summary relates only to joint stock limited companies incorporated under the Company Law.

Derivative action by minority shareholders

Hong Kong law allows minority shareholders to start a derivative action on behalf of the general body of shareholders in cases where, for example, one or more of the directors are in breach of duty and where their actions are shielded by the majority shareholders. The PRC Civil Procedure Law does not provide for such a procedure. Although the Company Law gives (a) shareholder(s) of a company the right to initiate proceedings in the People’s Court to restrain any resolution adopted by shareholders in general meeting or at a meeting of the board of directors which is in violation of any law or infringes the lawful rights and interests of the shareholder(s), there is no form of proceedings which is the same as a derivative action under the Companies Ordinance. However, each of the Directors and Supervisors (as required by the GEM Listing Rules) has given a written undertaking to the Company (acting as agent for each shareholder) to observe and comply with his obligations to shareholders stipulated in the Articles of Association. This allows minority shareholders to commence direct actions against defaulting Directors.

Remedies of the Company

Under the Company Law, if a director, supervisor or manager in carrying out his duties infringes any law or administrative regulation or the articles of association of a company, resulting in damage to the company, that director, supervisor or manager should be responsible to the company for such damages. In addition, in compliance with the GEM Listing Rules, remedies of the Company similar to those available under Hong Kong law (including rescission of the relevant contract and recovery of profits made by a Director, Supervisor or officer) have been set out in the Articles of Association.

Directors, officers and supervisors

The Company Law provides for the disqualification of directors, supervisors and managers in circumstances where they enter into business contracts with the Company, and for prohibitions of certain unauthorised benefits, but contains no provision restricting the authority of the directors to make major dispositions or prohibiting payment to them for loss of office without shareholders’ approval. The Company Law, unlike Hong Kong company law, does not contain restrictions on directors’ authority in making major dispositions, restrictions on companies providing certain benefits such as loans to directors and guarantees in respect of directors’ liability and prohibitions against compensation for loss of office without shareholders’ approval. Neither does the Company Law contain any requirements relating to the declaration of material interests in contracts with the

Company as is required under Hong Kong company law, nor restrictions on interested directors being counted towards the quorum of, and voting at, a meeting of the board of directors at which a transaction in which a director is interested is being considered. However, the Mandatory Provisions contain certain restrictions on major dispositions and specify the circumstances under which a director may receive compensation for loss of office, all of which provisions have been incorporated in the Articles of Association, a summary of which is set out in this Appendix.

Under Hong Kong company law, there is no concept of a supervisory committee for a company in addition to its board of directors, but a PRC joint stock limited company must have supervisors whose main duties include ensuring compliance with laws and regulations, and the articles of association of the company, by its directors and managers.

Each supervisor owes a duty, in the exercise of his powers, to act in good faith and honestly in what he or she considers to be the best interests of the company and to exercise the care, diligence and skill that a reasonably prudent person would exercise in comparable circumstances.

Minority protection

Under Hong Kong law, a shareholder who complains that the affairs of a company incorporated in Hong Kong are conducted in a manner unfairly prejudicial to his interests may present a petition to the court either to wind up the company or to make an appropriate order regulating the affairs of the company. In addition, at an application of a specified number of members, the financial secretary may appoint investigators who are given extensive statutory powers to investigate the affairs of a company incorporated in Hong Kong. There is no specific provision in the Company Law to guard against oppression by the majority shareholders of minority shareholders but the Company, as required by the Mandatory Provisions and the GEM Listing Rules, has adopted in the Articles of Association minority protection provisions similar to (though not as comprehensive as) those available under Hong Kong law, to the effect that a controlling shareholder may not exercise its voting rights in a manner prejudicial to the interests of other shareholders to relieve a director or supervisor of his or her duty to act honestly in the best interests of the company or to approve the expropriation by a director or supervisor of the company's assets or the individual rights of other shareholders.

Receiving agent

Under both PRC and Hong Kong law, dividends once declared become debts payable to shareholders, but the limitation of action period is two years in the PRC as opposed to six years in Hong Kong. The Articles of Association provide for the appointment of an agent in Hong Kong which must be a trust corporation registered under the Trustee Ordinance in Hong Kong to receive all dividends payable to H Share holders and all other monies owing by a joint stock limited company in respect of such H Shares on behalf of such shareholders as required by the GEM Listing Rules.

Financial assistance for the acquisition of shares

The Company Law does not contain any provision prohibiting or restricting a joint stock limited company or its subsidiaries from providing financial assistance for the purpose of an acquisition of its own or its holding company's shares. The Mandatory Provisions contain certain restrictions on a company and its subsidiaries providing such financial assistance similar to those under Hong Kong company law.

Variation of class rights

The Company Law makes no specific provision relating to variation of class rights. However, the Company Law states that the State Council can promulgate regulations relating to other kinds of shares. The Mandatory Provisions contain elaborate provisions relating to the circumstances which are deemed to be variations of class rights and the approval procedures required to be followed in respect thereof. These provisions have been incorporated in the Articles of Association, which are summarised in this Appendix. Under the Companies Ordinance, no rights attached to any class of shares can be varied except with the approval of a special resolution of the holders of the relevant class at a separate meeting or the consent in writing of the holders of three-fourths in nominal value of the issued shares of the class in question or by agreement of all the members of the Company or if there are provisions in the articles of association relating to the variation of those rights, then in accordance with those provisions. The Company (as required by the GEM Listing Rules and the Mandatory Provisions) has adopted in the Articles of Association provisions protecting class rights in a similar manner to those found in Hong Kong law. Holders of overseas listed foreign invested shares and domestic invested shares are defined in the Articles of Association as different classes. Normally if the Company intends to change the rights of shareholders in different classes, a special resolution has to be passed by the shareholders in general meeting and by a separate shareholders' meeting convened by the affected shareholders in the different classes. However, this procedure is waived where (i) the Company issues and allots, in any 12-month period, pursuant to a shareholders' special resolution, not more than 20% of each of the issued overseas listed foreign invested shares and the issued domestic invested shares existing as at the date of the shareholders' special resolution; and (ii) the plan for the issue of domestic invested shares and listed foreign invested shares upon its establishment is implemented within 15 months following the date of approval by the CSRC. The Mandatory Provisions contain detailed provisions relating to circumstances which are deemed to constitute a variation of class rights.

Corporate reorganisations

Corporate reorganisations involving compromises with creditors and members in respect of Hong Kong incorporated companies are dealt with under section 166 of the Companies Ordinance and require court sanction. Corporate reorganisation involving Hong Kong incorporated companies may also be effected by the transfer of the whole or part of the business or property of the company in the course of being wound up voluntarily to another company pursuant to section 237 of the Companies Ordinance. For PRC companies, such reorganisations are administratively considered and sanctioned under the Company Law.

Share capital

For a joint stock limited company formed under the Company Law, the registered share capital and the issued share capital are the same. For a Hong Kong company, the authorised share capital may be larger than the issued share capital. Hence, the directors of a Hong Kong company may, with the prior approval of the shareholders if required, cause the company to issue new shares. In the case of a PRC company, any increase of the registered capital must be approved by the shareholders in general meeting and the relevant PRC government and regulatory authorities. After completion of an approved new issue, the company has to register the increase in share capital with the relevant administration for industry and commerce.

The minimum registered capital of a company which has applied for the listing of its shares on stock exchange is RMB50 million under the Company Law. Hong Kong law does not prescribe any minimum capital requirements for a Hong Kong company.

Under the Company Law, the shares subscribed for in the form of intangible assets (excluding land use rights) may not exceed 20% of a joint stock limited company's registered capital. There is no such restriction under Hong Kong law on a Hong Kong company.

Restriction on shareholding and transfer of shares

The Company Law makes no reference to the class of shares which may be subscribed for or traded by overseas investors but has provisions that shares of a company to be listed overseas must comply with the Special Regulations. The Special Regulations and the Mandatory Provisions provide, among other things, that H shares must be in registered form and include such other matters as are referred to above. There is no restriction under Hong Kong law on a person's ability to deal in shares in a Hong Kong company on the basis of his residence or nationality.

Under the Company Law, shares in a joint stock limited company held by its promoters, directors or managers may not be transferred within certain periods of time. There is no such restriction under Hong Kong law.

Notice of meetings

Under the Company Law, shareholders of a joint stock limited company must be given 30 days' notice of a general meeting or, in the case of bearer shares, such notice should be published 45 days before the meeting. Under the Special Regulations and the Mandatory Provisions, 45 days' written notice must be given to all shareholders, and shareholders wishing to attend the meeting must reply in writing to reach the company 20 days before the date of the meeting. For a Hong Kong limited company, the minimum period of notice of a general meeting where convened for the purpose of considering ordinary resolutions is 14 days and where convened for the purpose of considering special resolutions, is 21 days. The notice period for an annual general meeting is also 21 days.

Quorum

Under Hong Kong company law, any two shareholders personally present will constitute a quorum for a general meeting, unless the articles of association provide otherwise. The Company Law makes no specific provision as to when a quorum is regarded as being present but the Special Regulations, the Mandatory Provisions and the Articles of Association provide that a company's annual general meeting can be convened when replies to the notice of that meeting have been received from shareholders whose shares represent 50% of the voting rights in the company at least 20 days before the proposed date of the meeting, or if that 50% level is not achieved, that the company shall within 5 days notify shareholders in a public announcement once again of the matters to be considered in the meeting as well as the date and place of the postponed meeting. Upon notification by public announcement, the Company may hold the shareholders' general meeting.

Voting

Under the Hong Kong company law, ordinary resolutions are passed by more than one-half of the votes cast by those shareholders voting in person or by proxy at a general meeting and special resolutions are passed by not less than three-quarters of such votes. Under the Company Law, the

passing of any resolution requires the passing by more than half of the votes of the shareholders attending and voting except in cases of proposed amendment to the articles of association, merger, division or dissolution of a company, where the approval of a two-thirds majority is required.

Dividends

The Articles of Association empower the Company to withhold, and pay to the relevant tax authorities, any tax payable under PRC law on any dividends or other distributions payable to a shareholder. Under Hong Kong law, the limitation period for an action to recover a debt (including the recovery of dividends) is six years, whereas under PRC laws, the relevant limitation period is two years.

The Company shall not exercise its powers to forfeit any unclaimed dividend in respect of H Shares until after the expiry of the applicable limitation period.

Financial disclosure

A joint stock limited company is required under the Company Law to make available at its office for inspection by shareholders its annual balance sheet, profit and loss account, statement of changes in financial situation and other relevant annexes 20 days before the annual general meeting of shareholders. In addition, a company established by the public subscription method under the Company Law must publish its financial statements. The annual balance sheet has to be verified by registered accountants. The Companies Ordinance requires a company to send to every shareholder a copy of its balance sheet, auditors' report and directors' report which are to be laid before the company in its annual general meeting not less than 21 days before such meeting.

Under the Articles of Association (as required by the GEM Listing Rules and the Mandatory Provisions), in addition to preparing accounts according to PRC accounting standards, the Company must have its accounts prepared and audited in accordance with international accounting standards or Hong Kong accounting standards and its financial statements must also contain a statement of the financial effect of the material differences (if any) from the financial statements prepared in accordance with the PRC accounting standards. The Company is required to publish its interim and annual accounts within 45 days from the end of the first six months of a financial year and within 90 days from the end of a financial year, respectively. The Company is further required to release quarterly reports within 45 days from the end of the first and third quarters of each financial year.

The Special Regulations require that there should not be any inconsistency between the information disclosed within and outside the PRC and that, to the extent that there are differences in the information disclosed in accordance with the relevant PRC and overseas laws, regulations and requirements of the relevant stock exchanges, such differences should also be disclosed simultaneously.

Information on directors and shareholders

The Company Law gives shareholders the right to inspect the Company's Articles of Association, minutes of the shareholders' general meetings and financial and accounting reports. Under the Articles of Association, shareholders have the right to inspect and copy (at reasonable charges) certain information on shareholders and on directors similar to that available to shareholders of Hong Kong companies under Hong Kong law.

Arbitration of disputes

In Hong Kong, disputes between shareholders and a company or its directors, managers and other senior officers can be resolved through the courts. The Articles of Association provide that disputes between a holder of H Shares and the Company and its directors, managers or other senior administrative officers or a holder of Domestic Shares arising from the Articles of Association, the Company Law or other relevant law or administrative regulation which concerns the affairs of the Company must, with certain exceptions, be submitted to arbitration at either the HKIAC or the CIETAC, at the claimant's choice. Such arbitration is final and conclusive.

Mandatory Deductions

Under the Company Law, after tax profits of a company are subject to deductions of contributions to the statutory common reserve fund and the statutory public welfare fund of a company before they can be distributed to shareholders. There are prescribed limits under the Company Law for such deductions. There are no corresponding provisions under the Companies Ordinance.

Fiduciary Duties

In Hong Kong, there is the common law concept of the fiduciary duty of directors. Under the Company Law and the Special Regulations, directors, supervisors, officers, and managers owe a fiduciary duty towards their company and are not permitted to engage in any activities which compete with or damage the interests of their company.

Closure of register of shareholders

The Companies Ordinance of Hong Kong requires that the register of shareholders of a company must not generally be closed for the registration of transfers of shares for more than 30 days (extendable to 60 days in certain circumstances) in a year, whereas the Company's Articles of Association provide, as required by the Company Law, that share transfers may not be registered within 30 days before the date of a shareholders' meeting or within five days before the record date set for the purpose of distribution of dividends.

(2) Other legal and regulatory provisions

Upon the listing of the Company on GEM, the provisions of the Securities and Futures Ordinance, the Takeovers Code and the Share Repurchases Code and such other relevant ordinances and regulations as may be applicable to companies listed on GEM will apply to the Company.

(3) Securities Arbitration Rules

The Articles of Association provide that certain claims arising under the Articles of Association or the Company Law shall be arbitrated at either CIETAC or HKIAC in accordance with their respective rules.

The Securities Arbitration Rules of HKIAC contain provisions allowing an arbitral tribunal to conduct a hearing in Shenzhen for cases involving disputes concerning the affairs of companies listed by the Hong Kong Stock Exchange and incorporated in the PRC (other than Hong Kong, Macau and Taiwan) so that PRC parties and witnesses may attend. Where any party applies for a hearing to take place in Shenzhen, the

tribunal shall, where satisfied that such application is based on bona fide grounds, order the hearing to take place in Shenzhen conditionally upon all parties including witnesses and the arbitrators being permitted to enter Shenzhen for the purpose of the hearing. Where any party (other than a PRC party) or any of its witnesses or any arbitrator is not permitted to enter Shenzhen, then the tribunal shall order that the hearing be conducted in any practicable manner, including the use of electronic media. For the purpose of the Securities Arbitration Rules, a PRC party means a party domiciled in the PRC other than the territories of Hong Kong, Macau and Taiwan.

(4) GEM Listing Rules

The GEM Listing Rules contain certain provisions specifically relating to the primary listing of equity securities of companies incorporated or otherwise established in the PRC. Set out below is a summary of the major provisions which apply to the Company.

Sponsor

The Company is required to retain, up to 31 December 2005 (or such shorter period as the Hong Kong Stock Exchange may, at its absolute discretion, permit) following its listing, the services of its sponsor or other financial adviser or professional firm which is acceptable to the Hong Kong Stock Exchange, to provide the Company with professional advice on continuous compliance with the GEM Listing Rules and to act at all times as the Company's principal channel of communication with the Hong Kong Stock Exchange, in addition to the two authorised representatives of the Company appointed pursuant to the GEM Listing Rules.

The Company must ensure that its sponsor has access at all times to its authorised representatives, Directors and other officers and is given such information and assistance as it may request in connection with the performance of its duties. The Company should also ensure that there are adequate and efficient means of communication between itself, its authorised representatives, Directors and other officers and the sponsor and should keep the sponsor fully informed of all communications and dealings between it and the Hong Kong Stock Exchange. The Company must not terminate the services of its sponsor until a replacement acceptable to the Hong Kong Stock Exchange is appointed. Where such sponsor's role is terminated by the Company, both the Company and the former sponsor should immediately notify the Hong Kong Stock Exchange of such termination, in each case stating the reason why such appointment was terminated, and the Company and the new sponsor should immediately notify the Hong Kong Stock Exchange of the new sponsor's appointment.

If the Hong Kong Stock Exchange is not satisfied that the sponsor is fulfilling its responsibilities adequately under the GEM Listing Rules, it may require the Company to terminate the sponsor's appointment and appoint a replacement as soon as possible. The Company and the new sponsor should immediately notify the Hong Kong Stock Exchange of the new sponsor's appointment.

The sponsor must be satisfied that the Company is suitable to be listed, that the Directors and the Supervisors appreciate the nature of their responsibilities and can be expected to honor their obligations under their respective undertakings, the GEM Listing Rules and applicable laws and regulations and that the Directors understand what is required of them under the GEM Listing Rules and applicable laws and regulations.

The sponsor must keep the Company informed on a timely basis of changes in the GEM Listing Rules and any new or amended law, regulation or code in Hong Kong applicable to the Company. The sponsor must provide advice to the Company on the continuing requirements under the GEM Listing Rules and applicable laws and regulations. It must act as the Company's principal channel of communication with the Hong Kong Stock Exchange if the authorised representatives of the Company are expected to be frequently outside Hong Kong.

Accountants' reports

An accountants' report will not normally be regarded as acceptable by the Hong Kong Stock Exchange unless the financial history of results and statement of assets and liabilities included in the accountants' report have been audited to a standard comparable to that required in Hong Kong which means that it must conform with either Hong Kong or international accounting standards.

Process agent

The Company must appoint and maintain throughout the period during which its securities are listed on GEM the appointment of a person authorised to accept service of process and notices on its behalf in Hong Kong and must notify the Hong Kong Stock Exchange of his or her appointment and any termination of his or her appointment and his or her contact particulars.

Public shareholdings

If at any time there are existing issued securities of the Company other than H Shares which are listed on the Hong Kong Stock Exchange, the GEM Listing Rules require that (i) all H Shares must be held by the public except as otherwise permitted by the Hong Kong Stock Exchange in its discretion; (ii) the H Shares held by the public must constitute not less than 10% of the Company's total existing issued share capital; and (iii) the aggregate amount of H Shares and other securities held by the public must constitute not less than the minimum prescribed percentage of the Company's total existing issued share capital as set out in the GEM Listing Rules (25% if the Company's market capitalisation does not exceed HK\$4 billion; or the higher of either (a) the percentage that would result in the market value of the securities to be in public hands equal to HK\$1 billion (determined at time of listing) or (b) 20% if the market capitalisation is over HK\$4 billion).

If the Company does not have existing issued securities other than H Shares, the H Shares held by the public must constitute not less than the minimum prescribed percentages as above.

Independent non-executive directors and supervisors

The independent non-executive Directors are required to demonstrate an acceptable standard of competence and adequate commercial or professional expertise to ensure that the interests of the general body of shareholders will be adequately represented. At least one of the independent non-executive Directors must be ordinarily resident in Hong Kong. The Supervisors must have the character, experience and integrity and be able to demonstrate a standard of competence commensurate with their position as supervisors.

Restrictions on purchase and subscription

The Company may purchase its own Shares on GEM or on another stock exchange in accordance with the GEM Listing Rules and the Takeovers Code. Shareholders' approvals must first be obtained prior to carrying out a share repurchase, by way of the special resolutions of shareholders in general meetings and of the holders of Domestic Shares and the holders of H Shares at separate class meetings, in accordance with the procedures prescribed by the Articles of Association. When seeking shareholders' approval to make purchases of its securities on GEM or when reporting such purchases, the Company should provide information to its shareholders on the proposed or actual purchase of any or all of its equity securities, whether or not listed or traded on GEM. There should also be a statement as to the consequences of any purchases which will arise under either or both of the Hong Kong Code on Takeovers and Mergers and any similar applicable law of which the Directors are aware, if any. Any specific approval or general mandate given to the Directors to repurchase H Shares must not exceed 10% of the total amount of existing issued H Shares of the Company.

With a view to increasing the level of protection afforded to investors, the Hong Kong Stock Exchange requires the incorporation, in the articles of association of a PRC company whose primary listing is on the Hong Kong Stock Exchange, of the Mandatory Provisions and provisions including those relating to the change, removal and resignation of auditors, classification of shareholders and the conduct of the supervisory committee of the Company. Such provisions have been incorporated into the Articles of Association, a summary of which is set out in this Appendix.

Corporate governance

The Company shall comply with Chapter 17 of the GEM Listing Rules, the major provisions of which may be summarised as follows:

(1) Redeemable shares

The Company shall not issue any redeemable shares unless the Hong Kong Stock Exchange is satisfied that the relative rights of the holders of the H Shares are adequately protected. The Company shall inform the Hong Kong Stock Exchange as soon as possible after any purchase, sale, drawing or redemption by the Company, or any of its subsidiaries, of its securities.

(2) Preemptive rights

Except in the circumstances mentioned below, the Directors must obtain the approval by a special resolution of Shareholders in general meeting, and the approvals by special resolutions of holders of Domestic Shares and holders of H Shares (each being otherwise entitled to vote at general meetings) at separate class meetings conducted in accordance with the Articles of Association prior to:

- (i) authorising, allotting, issuing or granting;
 - (a) shares;
 - (b) securities convertible into shares; or

- (c) options, warrants or similar rights to subscribe for any shares or such convertible securities; or
- (ii) any major subsidiary of the Company making any such authorisation, allotment, issue or grant so as materially to dilute the percentage equity interest of the Company and its shareholders in such subsidiary.

Notwithstanding in the circumstances mentioned below, the Directors shall obtain the approval by special resolution of the Shareholders in general meeting prior to allotting any voting shares if such allotment would effectively alter the control of the Company.

No such approval shall be required in the case of authorising, allotting or issuing shares if, but only to the extent that, the existing shareholders of the Company have by special resolution in general meeting given approval, either unconditionally or subject to such terms and conditions as may be specified in the resolution, for the Company to authorise, allot or issue either separately or concurrently once in every 12 months (commencing on the date on which the Shareholders pass such resolutions), not more than 20% of each of the existing Domestic Shares and H Shares as at the date of the passing of the relevant special resolution or such shares are part of the Company's plan at the time of its establishment to issue Domestic Shares and H Shares and which plan is implemented within 15 months from the date of approval by the State Council Securities Policy Committee.

(3) *Changes to articles of association*

The Company shall inform the Hong Kong Stock Exchange of any decision made in regard to any proposed alteration of the Company's Articles of Association and any proposed request by the Company to a PRC competent authority to waive or otherwise notify any provision of the Special Regulations.

(4) *Documents for inspection*

The Company must make available at a place in Hong Kong for inspection by the public and shareholders free of charge, and for copying by shareholders at reasonable charges, the following:

- (a) a complete duplicate register of Shareholders;
- (b) a report showing the state of the issued share capital of the Company;
- (c) the Company's latest audited financial statements and the Directors', auditors' and Supervisors' reports thereon;
- (d) special resolutions of the Company;
- (e) reports showing the number and nominal value of securities repurchased by the Company since the end of the last financial year, the aggregate amount paid for such securities and the maximum and minimum prices paid in respect of each class of securities repurchased (with a breakdown between Domestic Shares and H Shares);

- (f) a copy of the latest annual return filed with the PRC State Administration for Industry and Commerce or other competent PRC authority; and
- (g) for shareholders only, copies of the minutes of meetings of Shareholders.

(5) *Appointment of receiving agents*

The Company must appoint one or more receiving agents in Hong Kong and pay to such agents dividends declared and other monies owing by the Company in respect of H Shares listed on the Hong Kong Stock Exchange to be held, pending payment, in trust for holders of the H Shares.

(6) *Statements to be made on acquisition of shares*

The Company must ensure that all its listing documents and share certificates include the statements stipulated below and must instruct and cause its share registrar not to register the subscription, purchase or transfer of any of its Shares in the name of any particular holder unless and until such holder delivers to such share registrar a signed form in respect of such shares bearing statements to the following effect:

- (a) The acquirer of Shares agrees with the Company and each shareholder of the Company, and the Company agrees with each shareholder, to observe and comply with the Company Law, the Special Regulations and the Articles of Association.
- (b) The acquirer of Shares agrees with the Company, each shareholder, Director, Supervisor, manager and officer of the Company and the Company acting for itself and for each Director, Supervisor, manager and officer agrees with each shareholder to refer all differences and claims arising from the Articles of Association or any rights or obligations conferred or imposed by the Company Law or other relevant laws and administrative regulations concerning the affairs of the Company to arbitration in accordance with the Articles of Association. Any reference to arbitration shall be deemed to authorise the arbitration tribunal to conduct its hearing in open session and to publish its award. Such arbitration shall be final and conclusive.
- (c) The acquirer of Shares agrees with the Company and each shareholder of the Company that H Shares in the Company are freely transferable by the holder thereof.
- (d) The acquirer of Shares authorises the Company to enter into a contract on his behalf with each Director and officer whereby such Directors and officers undertake to observe and comply with their obligations to shareholders stipulated in the Articles of Association.

(7) *Compliance with the Company Law, the Special Regulations and the Articles of Association*

The Company must observe and comply with the Company Law, the Special Regulations and the Articles of Association.

(8) *Contract between the Company and every Director and officer*

The Company must enter into a contract in writing with every Director and officer containing at least the following provisions:

- (a) an undertaking by the Director or officer to the Company to observe and comply with the Company Law, the Special Regulations, the Articles of Association, the Hong Kong Code on Takeovers and Mergers and the Code on Share Repurchases and an agreement that the Company shall have the remedies provided in the Articles of Association and that neither the contract nor his office is capable of assignment;
- (b) an undertaking by the Director or officer to the Company acting as agent for each shareholder to observe and comply with his obligations to shareholders stipulated in the Articles of Association; and
- (c) an arbitration clause which provides that whenever any disputes or claims arise from the Articles of Association or any rights or obligations conferred or imposed by the Company Law or other relevant laws and administrative regulations concerning the affairs of the Company between (1) the Company and its Directors or officers and (2) a holder of overseas listed foreign invested shares and a Director or officer of the Company, such disputes or claims shall be resolved through arbitration at either CIETAC in accordance with its arbitration rules or HKIAC in accordance with its Securities Arbitration Rules, at the election of the party seeking arbitration. Where a dispute or claim described above is referred to arbitration, the entire dispute or claim shall be resolved through that arbitration; all persons who have a cause of action based on the same facts giving rise to the dispute or claim or whose participation is necessary for the resolution of such dispute or claim, if they are shareholders, Directors, Supervisors, managers or other officers of the Company or the Company, shall submit to arbitration.

Disputes over who is a shareholder and over the share register do not have to be resolved through arbitration.

If the party seeking arbitration elects to arbitrate the dispute or claim at HKIAC, then either party may apply to have such arbitration conducted in Shenzhen according to the Securities Arbitration Rules of HKIAC. Once the party seeking arbitration submits a dispute or claim to arbitration, the other party must submit to the arbitral body selected by the party seeking the arbitration.

PRC laws shall govern the arbitration of disputes or claims referred to above, unless otherwise provided by law or administrative regulations. The award of the arbitral body is final and shall be binding on the parties thereto.

The agreement to arbitrate is made by the Director or officer with the Company on its own behalf and on behalf of each shareholder. Any reference to arbitration is deemed to authorise the arbitral tribunal to conduct hearings in open session and to publish its award.

(9) *Contract between the Company and every Supervisor*

The Company must enter into a contract in writing with every Supervisor containing at least the following provisions:

- (a) an undertaking by the Supervisor to the Company to observe and comply with the Company Law, the Special Regulations and the Articles of Association and an agreement that the Company will have the remedies provided in the Articles of Association and that neither the contract nor his office is capable of assignment;
- (b) an undertaking by the Supervisor to the Company acting as agent for each shareholder to observe and comply with his obligations to shareholders stipulated in the Articles of Association; and
- (c) the arbitration clause in terms set out in sub-paragraph (8)(c) above subject to necessary modifications.

(10) *Subsequent listing*

The Company must apply for the listing of any further securities which are of the same class as securities already listed, prior to their issue, and must not issue such securities unless it has applied for the listing of these securities. The Company must not apply for the listing of any of its foreign invested shares on a PRC stock exchange unless the Stock Exchange is satisfied that the relative rights of the holders of overseas listed foreign shares are adequately protected.

(11) *English translation*

All notices or other documents required under the GEM Listing Rules to be sent by the Company to the Stock Exchange or to holders of H Shares shall be in the English language with a Chinese translation or in Chinese with an English translation.

General

If changes in the PRC law or market practices materially alter the validity or accuracy of any of the bases upon which the above requirements have been prepared, then the Stock Exchange may impose additional requirements or make the listing of the equity securities of a PRC issuer, including the Company, subject to such special conditions as the Stock Exchange considers appropriate. Whether or not any such changes in the PRC law or market practices occur, the Stock Exchange retains its general power under the GEM Listing Rules to impose additional requirements and make special conditions in respect of the listing of the shares of the Company.

III. ARTICLES OF ASSOCIATION

Set out below is a summary of the principal provisions of the Articles of Association which have incorporated the Mandatory Provisions as supplemented by the Opinion Regarding the Supplemental Amendments to the Articles of Association of Companies to be Listed in Hong Kong jointly promulgated by CSRC and the State Commission for Restructuring the Economic System (國家經濟體制改革委員會). The Articles of Association were adopted by a special resolution passed by shareholders in an extraordinary general meeting held on 24 April 2004. A copy of the Chinese text of the Articles of Association is available for inspection as mentioned in the paragraph headed "Documents available for inspection" in Appendix VIII to this prospectus.

(I) Directors

(a) *Power to allot and issue shares*

There are no provisions in the Articles of Association empowering the Directors to allot and issue shares. In order to increase the share capital of the Company, the board of Directors shall prepare a proposal for an allotment of shares in the Company, and submit the same to shareholders in general meeting for their approval by way of a special resolution. The board of Directors shall then submit the proposal for the share allotment to the securities regulatory authorities of the State Council for approval, and, subject to such approval being obtained, make separate arrangements to implement the share allotment.

(b) *Power to dispose of the Company's or of any of its subsidiaries' assets*

The Directors shall not, without the prior approval of shareholders in general meeting, dispose or agree to dispose of any fixed assets of the Company if the aggregate of:

- (i) the expected value of the fixed assets proposed to be disposed of; and
- (ii) the total consideration received by the Company for all disposals of fixed assets which took place within the period of four months immediately preceding the proposed disposal,

exceeds 33% of the value of the Company's fixed assets as shown in the latest balance sheet placed before the shareholders in general meeting. For the purposes of this provision, a disposal of fixed assets includes an act involving the transfer of an interest in fixed assets but does not include the provision of security over the fixed assets of the Company under a guarantee. The validity of a transaction entered into by the Company for the disposal of fixed assets by the Company shall not be affected by a breach of this provision.

(c) *Compensation or payments for loss of office*

The Company shall enter into a contract in writing with each Director and Supervisor in respect of remuneration for his services, with the prior sanction of the shareholders in a general meeting. The aforesaid remuneration shall include: inter alia, monies payable to the Director or Supervisor as compensation for the loss of office or upon retirement from office. A contract of remuneration entered into between the Company and its Director or Supervisor shall make provisions for that Director or Supervisor to receive compensation for loss of office or upon retirement in the event of a takeover of the Company, subject to obtaining the prior approval of shareholders at a general meeting. "Takeover of the Company" refers to any one of the following circumstances:

- (i) an offer made by any person to all shareholders of the Company; or
- (ii) an offer made by any person with a view to the offeror becoming a controlling shareholder (as defined in the Articles of Association) of the Company.

If the relevant Director or Supervisor does not comply with the above provision, any payment received by him shall belong to those persons who have sold their shares by reason of their acceptance of the offer made, and the expenses incurred in distributing the monies pro rata amongst those persons shall be borne by that Director or Supervisor and shall not be deducted from the monies to be distributed.

(d) *Loans to Directors*

The Company shall not, directly or indirectly, make a loan or provide any guarantee for a loan to its Director, Supervisor, general manager, deputy general manager or other senior officer, or to a Director, Supervisor, general manager, deputy general manager or other senior officer of its holding company, or to a relevant party (as described in section (f) below) the aforementioned officers in the manner described in section (f) below. The prohibitions contained in this section shall not apply in the following circumstances:

- (a) the provision of a loan or a guarantee for a loan by the Company to a subsidiary of the Company;
- (b) pursuant to an employment contract approved by the shareholders' general meeting, the provision by the Company to a Director, Supervisor, general manager, deputy general manager or other senior officer of a loan or a guarantee for a loan or other funds to meet expenditure incurred by him in the interest of the Company or for the purpose of enabling him to perform his duties for the Company; and
- (c) where the ordinary course of business of the Company includes money lending or the provision of guarantees, the Company may make a loan to or provide a guarantee for a loan to a Director, Supervisor, general manager, deputy general manager or other senior officer or their relevant party (as described in section (f) below), provided that the terms of the loan or guarantee for a loan are on normal commercial terms.

A loan made by the Company in breach of the prohibition described above shall be repaid immediately by the recipient of the loan, regardless of the terms of the loan. A guarantee provided by the Company in breach of the prohibition described above shall not be enforceable against the Company, except in the following circumstances:

- (i) the lender was not aware of the relevant circumstances at the time the loan was advanced to the relevant party (as described in section (f) below) of a Director, Supervisor, general manager, deputy general manager or other senior officer of the Company or its holding company; and
- (ii) the security provided by the Company has been lawfully sold by the lender to a bona fide purchaser.

For the purpose of the foregoing provisions, a guarantee includes giving an undertaking or providing security over the assets of the guarantor to secure performance of the obligations of the obligor.

(e) *Giving of financial assistance to purchase the Company's or any of its subsidiaries shares*

The Company and its subsidiaries shall not at any time and in any manner give any form of financial assistance to a person who purchases or intends to purchase the shares of the Company. For the purpose of this provision, a purchaser of the Company's shares includes a person who directly or indirectly assumes any form of obligations as a result of a purchase of the Company's shares. The Company and its subsidiaries shall not at any time and in any manner provide any form of financial assistance for the purpose of reducing or discharging such obligations.

For the purpose of the Articles of Association,

- (i) “financial assistance” includes (but is not limited to) financial assistance provided by way of:
 - (1) gift;
 - (2) guarantee (including cases where the guarantor assumes any obligation(s) or provides security over his or its assets in order to secure the performance of obligations by the obligor), indemnity (other than an indemnity given in respect of the Company's own default), release or waiver;
 - (3) a loan or a contract under which the obligations of the Company have to be fulfilled before the obligations of the other side, or a change of the parties to that loan or contract, or the assignment of any rights under the loan or contract; or
 - (4) financial assistance given in any other form under circumstances whereby the Company is unable to pay its debts or has no net assets, or whereby its net assets may be reduced by a material extent; and
- (ii) any reference to an assumption of obligation(s) includes situations where the obligor enters into a contract or makes any arrangement (whether or not such contract or arrangement is enforceable, and whether or not the obligations under such a contract or arrangement are to be borne by that one party alone or together with any other party or parties) and situations where a party's financial position is changed, without regard to the means by which that change is brought about.

The following acts shall not be deemed prohibited by the Articles of Association:

- (i) where the financial assistance is provided by the Company in good faith and in the interests of the Company, and the main purpose of that assistance is not to facilitate the acquisition of shares in the Company or that financial assistance is an incidental part of some broader purpose of the Company;
 - (ii) where the Company is lawfully distributing its assets by way of dividend;
 - (iii) the distribution of a dividend by way of an allotment of bonus shares;
 - (iv) a reduction of the Company's registered capital, a repurchase of the Company's shares or a reorganisation of the structure of the Company's share capital etc. in accordance with the Articles of Association;
 - (v) where the Company provides a loan which is within its scope of operations and which is in the ordinary course of its business (provided that the Company's net assets are not reduced as a result of such a loan or where the Company's net assets are reduced, to the extent that those assets are reduced, the financial assistance is provided out of distributable profits of the Company); and
 - (vi) contributions of money by the Company to employees' share schemes (provided that the Company's net assets are not reduced as a result of such contributions or where the Company's net assets are reduced, to the extent that those assets are reduced, the financial assistance is provided out of distributable profits of the Company).
- (f) *Disclosure of interests in contracts with the Company or any of its subsidiaries*

Subject to such exceptions specified in the Articles of Association as the Stock Exchange may approve, a Director shall not vote on any board resolution approving any contract or arrangement or any other proposal in which he or any of his associates has a material interest nor shall he be counted

in the quorum present at the meeting. Subject to the above, where a Director, Supervisor, general manager, deputy general manager or other senior officer of the Company has, directly or indirectly, a material interest in a contract, transaction or arrangement entered into or proposed to be entered into by the Company (other than his contract of employment), he shall declare the nature and extent of his interest to the board of Directors at the earliest opportunity, whether or not the matters in question are otherwise subject to the approval of the board of Directors. Unless the Director, Supervisor, general manager or other senior officer with an interest makes a disclosure to the board of Directors in the manner just described in this paragraph and the matter is approved by the board of Directors at a meeting at which he was not counted in the quorum and did not vote, the Company may rescind that contract, transaction or arrangement except as against a bona fide party acting in good faith and without notice of the breach of duty by that Director, Supervisor, general manager, deputy general manager or senior officer. For the purposes of this provision, a Director, Supervisor, general manager, deputy general manager or other senior officer is deemed to have an interest in a contract, transaction or arrangement in which a person connected to him (in the manner described below in this section (f)) has an interest.

If, prior to the date on which the Company first considered the question of entering into the relevant contract, transaction or arrangement, the Director, Supervisor, general manager, deputy general manager or other senior officer gives the board of Directors a notice in writing stating that by reason of the matters stated in the notice, he has an interest in a contract, transaction or arrangement proposed to be entered into by the Company, then that Director, Supervisor, general manager, deputy general manager or senior officer shall be deemed to have made a disclosure for the purpose of and in accordance with this section to the extent of the matters disclosed in that notice.

A person is connected with a Director, Supervisor, general manager, deputy general manager or other senior officer ("relevant party") if he/she is:

- (i) the spouse or minor child of that Director, Supervisor, general manager, deputy general manager or other senior officer;
 - (ii) a person acting as trustee for that Director, Supervisor, general manager, deputy general manager or other senior officer or as a trustee for any person referred to in (i) above;
 - (iii) a person who is a partner of that Director, Supervisor, general manager, deputy general manager or other senior officer or a partner of any person referred to in (i) and (ii) above;
 - (iv) a company in which that Director, Supervisor, general manager, deputy general manager or other senior officer, alone or together with any persons referred to in (i), (ii) and (iii) above, or together with other Director(s), Supervisor(s), general manager(s), deputy general manager(s) or senior officer(s) have de facto control; or
 - (v) a Director, Supervisor, general manager, deputy general manager or other senior officer of a company referred to in (iv) above.
- (g) *Remuneration*

The Company shall enter into a contract in writing with each Director and Supervisor in respect of remuneration for his services, with the prior sanction of the shareholders' general meeting. Such remuneration shall include:

- (i) remuneration for his services as Director, Supervisor or other senior officer of the Company;
- (ii) remuneration for his services as Director, Supervisor or other senior officer of a subsidiary of the Company;

- (iii) remuneration in respect of other services provided in connection with the management of the affairs of the Company or its subsidiaries; and
- (iv) payment to the Director or Supervisor as compensation for loss of his office or upon his retirement from office.

Except pursuant to a contract as described above, a Director or Supervisor shall not institute any proceedings against the Company for any benefit due to him in respect of the above matters.

(h) *Appointment, removal and retirement*

All Directors shall be elected by the shareholders' general meeting and shall serve a term of three years from the date of their respective elections. Upon the expiry of his term of office, a Director may be re-elected to serve consecutive terms. The minimum period during which a notice of an intention to nominate a person for election as a Director and a notice in writing by that person of his acceptance of such nomination shall be at least seven days and that the period for lodgment of such notices shall commence no earlier than the day after the dispatch of the notice of the general meeting appointed for such election and end no later than seven days prior to the date of such general meeting. The board of Directors shall consist of ten Directors, comprising at least 50% or more external Directors (Directors who do not hold offices in the Company) and at least three independent non-executive Directors. The chairman and vice-chairmen shall be appointed and removed by a majority of the Directors. The chairman and vice-chairmen shall serve a term of three years and may be re-elected to serve consecutive terms upon the expiry of the terms of their offices.

Subject to compliance with the relevant laws and administrative regulations, a shareholders' general meeting may by way of a special resolution remove any Director before the expiry of the term of his office (but without prejudice to any claim for compensation pursuant to any contract). A Director is not required to hold shares in the Company. There is no stipulation that a Director must retire at a certain age.

Any person appointed by the Directors to fill a casual vacancy on or as an addition to the board of Directors shall hold office only until the next following annual general meeting of the Company and shall then be eligible for re-election at that meeting.

(i) *Borrowing powers*

The board of Directors has the function and powers to formulate proposals for an increase or reduction of the Company's registered capital and the issue of debt securities. In addition, subject to compliance with the requirements of the relevant laws, regulations, the Articles of Association and any applicable rules, the board of Directors may exercise the Company's powers to raise capital and to borrow, to make decisions regarding the mortgaging, letting, sub-contracting or transferring the Company's major assets, and to delegate the aforementioned powers to the general manager, deputy general manager within certain limits.

(j) *Qualification shares*

There is no requirement for Directors to hold qualification shares.

(2) Alterations to constitutional documents

The Company may amend any provision contained in the Articles of Association in accordance with the provisions of the relevant laws, administrative regulations and the Articles of Association.

Any amendment to the Articles of Association which involves amending the Mandatory Provisions shall become effective only after the approval of the companies supervisory authorities of the State Council and

the approval of the CSRC are obtained; any amendment involving a change in the particulars of the companies registration shall be registered in accordance with the law.

(3) Variation of rights of existing shares or classes of shares

If the Company proposes to vary or abrogate the rights of a class of shareholders, the variation or abrogation must be approved by a special resolution of the shareholders' in general meeting and by the affected class of shareholders at a separate meeting convened and conducted in accordance with the Articles of Association before it may proceed.

The following events shall be deemed to be a variation or abrogation of the rights of a class of shareholders:

- (i) an increase or decrease in the number of shares in that class, or an increase or decrease in the number of shares of a class which have voting rights, distribution rights or other rights which are equal or superior to the shares of that class;
- (ii) an exchange of all or part of the shares of that class for the shares of a different class or the exchange of all or part of the shares of a different class for the shares of that class or the grant of a right or rights to such conversion;
- (iii) a cancellation or reduction of the right to accrued dividends or the right to cumulative dividends attached to that class of shares;
- (iv) a reduction or cancellation of the preferential rights of that class of shares to dividends or a distribution of surplus assets in the event of the winding up or liquidation of the Company;
- (v) an increase, cancellation or reduction of any conversion right, option, voting right, transfer right, pre-emptive placing right or right to acquire securities of the Company attached to that class of shares;
- (vi) a cancellation or reduction of any right attached to that class of shares to receive payment from the Company in specified currencies;
- (vii) a creation of a new class of shares which have voting rights, distribution rights or other rights equal or superior to that class of shares;
- (viii) a creation or increase of restrictions on the right of transfer or ownership attached to that class of shares;
- (ix) an issue of rights to subscribe for, or convert into, shares of that class or other class(es);
- (x) an increase in the right or privileges of another class or other classes of shares;
- (xi) a restructuring of the Company which will result in a class of shareholders bearing disproportionate amount of obligations to another class in the course of such restructuring; and
- (xii) a variation or abrogation of the provisions in the Articles of Association relating to special procedures for voting by holders of different classes of shares.

Class meetings shall be conducted, as far as is possible, in the same manner as shareholders' general meetings. The provisions of the Articles relating to the manner of conducting any shareholders' general meeting shall apply to any class meeting of shareholders. Holders of domestic and foreign shares are deemed to be different classes of shareholders.

The special voting procedures for class shareholders shall not apply in the following circumstances:

- (1) where the Company issues, upon approval by a special resolution of its shareholders in a general meeting, either separately or concurrently once every twelve months, not more than 20 per cent. of each of its existing issued domestic shares and overseas listed foreign shares; or
- (2) where the Company's plan to issue domestic shares and overseas listed foreign shares at the time of its incorporation is implemented within fifteen months from the date of approval by CSRC or such other competent state council securities regulatory authority.

(4) Ordinary and special resolutions – a majority required

Resolutions of shareholders passed at general meetings shall be divided into ordinary resolutions and special resolutions. An ordinary resolution shall be passed by more than one half of the votes represented by the shareholders (including proxies) present at the shareholders' general meeting. A special resolution shall be passed by more than two thirds of the votes represented by the shareholders (including proxies) present at the shareholders' general meeting.

(5) Voting rights (generally, on a poll and right to demand a poll)

An ordinary shareholder of the Company has the right to attend and vote, or to appoint a proxy or proxies to attend and vote on his behalf, at shareholders' general meetings. Shareholders (including proxies) shall exercise such voting rights at shareholders' general meeting as they may have in accordance with the number of shares they hold which carry the right to vote with each share carrying one vote. At any shareholders' meeting, voting shall be by a show of hands unless a poll (before or after a vote by a show of hands) is demanded by the following persons:

- (a) the chairman of the meeting;
- (b) at least two shareholders, present in person or by proxy, who have the right to vote; or
- (c) one or more shareholders or his/their proxy who, alone or together, represent 10% or more of the shareholding represented at the meeting which carry the right to vote at that meeting.

Unless a poll is demanded, a declaration by the chairman based on the result of the show of hands as to whether a resolution has been passed and an entry to that effect in the minutes of the meeting shall be conclusive evidence of the result of that vote without further proof of the number of votes recorded or the percentage of votes in favour of and against such resolution at the meeting. The demand for a poll may be withdrawn by the person(s) who demanded it. A poll demanded on a vote regarding the election of the chairman of the meeting, or on a question of adjournment of the meeting, shall be taken immediately. A poll demanded on any other matters shall be taken at such time as the chairman of the meeting decides, and the meeting may proceed to other matters. The results of a poll shall be deemed to be a resolution of the meeting at which the poll was demanded on a poll taken at a meeting. A shareholder (including his proxy) entitled to two or more votes need not cast all his votes in the same way. In the case of an equality of votes, whether on a show of hands or on a poll, the chairman of the meeting shall be entitled to an additional vote.

(6) Requirements for general meetings

Shareholders' general meetings are divided into annual general meetings and extraordinary general meetings. Shareholders' general meetings shall be convened by the board of Directors. Annual general meetings shall be held once every year within six months after the end of each financial year.

(7) Accounts and audit*(a) Financial and accounting system*

The Company shall formulate its financial accounting system in accordance with the relevant laws, administrative regulations and the principles relating to PRC accounting standards formulated by the financial supervisory authorities of the State Council. The Company shall prepare a financial report at the end of every financial year and shall have it audited in accordance with the law. The board of Directors shall place before the shareholders at every annual general meeting such financial reports as required by the relevant laws, administrative regulations or prescribed documents required by regional governments and supervisory authorities to be prepared by the Company. The financial reports of the Company shall be made available at the Company 20 days prior to the annual general meeting of the Company, for inspection by its shareholders. Every shareholder of the Company shall have the right to obtain a copy of the financial reports referred to above. A copy of the above financial reports accompanied by the Directors' report shall, at least 21 days before the date of the annual general meeting, be sent by prepaid post by the Company to every holder of overseas listed foreign shares at his/ her address as entered in the register of members.

The financial statements of the Company shall, in addition to complying with the PRC accounting standards, rules and regulations, be prepared in accordance with either international accounting standards or overseas accounting standards of the place at which foreign shares of the Company are listed. If there are material differences between the financial statements prepared in accordance with the aforesaid accounting standards, then the notes to those financial statements shall state and explain such differences. For the purposes of distributing the Company's profits after tax in a financial year, the Company's profits after tax shall be deemed to be the lesser of the amounts stated in the different sets of financial statements. Any interim results and quarterly results or financial information announced or disclosed by the Company shall be prepared in accordance with PRC accounting standards, rules and regulations as well as in accordance with either international accounting standards or overseas accounting standards of the place where the foreign shares of the Company are listed.

The Company shall prepare quarterly reports in respect of the first 3 and 9 months periods of each financial year of the Company containing at least the information required by the GEM Listing Rules and publish the same not later than 45 days after the end of such period.

The Company shall also prepare an interim report in respect of the first 6 months period in each financial year of the Company containing at least the information required by the GEM Listing Rules and publish the same not later than 45 days after the end of such period.

(b) Appointment and removal of auditors

The appointment, dismissal or termination of employment of an auditor shall be determined at shareholders' general meetings and reported to the CSRC for record. The first auditor of the Company may be appointed at the Company's inaugural meeting and the auditor so appointed shall hold office until the conclusion of the first annual general meeting. The term of appointment of an auditor appointed by the Company shall commence from the conclusion of the annual general meeting at which the appointment took place until the conclusion of the next annual general meeting of the Company. The board of Directors may appoint an auditor to fill any casual vacancy in the office of auditors, provided that if another auditor is acting for the Company during any such vacancy, that auditor may continue to act. Shareholders in general meeting may by ordinary resolution remove an auditor before his term of office expires, irrespective of any provisions contained in the contract entered into between the Company and the auditor. Any right of the auditor to claim compensation against the Company for the termination of this office shall not be affected by such termination. Remuneration of the auditor and the manner by which it is determined shall be decided by shareholders in general meeting. Where the auditor is appointed by the board of Directors, his remuneration shall be determined by the board of Directors.

Where a resolution at a general meeting of shareholders is passed to appoint as auditor a person other than an incumbent auditor, to fill a casual vacancy in the office of auditor, to reappoint as auditor a retiring auditor who was appointed by the board of directors to fill a casual vacancy, or to remove an auditor before the expiration of his term of office, the following provisions shall apply:—

- (1) A copy of the proposal shall be sent before notice of meeting is given to the shareholders to the person proposed to be appointed or the auditor proposing to leave his post or the auditor who has left his post (leaving includes leaving by removal, resignation and retirement).
- (2) If the auditor leaving his post makes representations in writing and requests their notification to the shareholders, the Company shall (unless the representations are received too late):—
 - (i) in any notice of the resolution given to shareholders, state the fact of the representations having been made; and
 - (ii) send a copy of the representations to every shareholder entitled to notice of general meetings and deliver it to the shareholders in the manner stipulated in the Articles.
- (3) If the auditor's representations are not sent in accordance with the preceding paragraph, the auditor may (in addition to his right to be heard) require that the representations be read out at the meeting.
- (4) An auditor who is leaving his post shall be entitled to attend:—
 - (i) the general meeting at which his term of office would otherwise have expired;
 - (ii) any general meeting at which it is proposed to fill the vacancy caused by his removal; and
 - (iii) any general meeting convened on his resignation;

and to receive all notices of, and other communications relating to, any such meeting, and to be heard at any such meeting which he attends on any part of the business of the meeting which concerns him as former auditor of the Company.

(c) *Resignation of auditors*

Where an auditor resigns his post, it shall be made clear to the shareholders' general meeting whether there has been any impropriety on the part of the Company.

An auditor may resign its office by depositing at the Company's registered office a resignation notice which shall become effective on the date of such deposit or on such later date as may be stipulated in such notice. Such notice shall include the following:

- (1) a statement to the effect that there are no circumstances connected with its resignation which it considers should be brought to the notice of the shareholders or creditors of the Company; or
- (2) a statement of any such circumstances.

Where a notice is deposited under the preceding paragraph, the Company shall within 14 days send a copy of the notice to the relevant governing authority. If the notice contains a statement under paragraph (2) above, a copy of such statement shall be kept at the Company for shareholders' inspection. A copy of such statement shall also be sent by prepaid mail to all holders of H Shares at the addresses registered in the register of shareholders.

Where the auditor's notice of resignation contains a statement of any circumstances which should be brought to the notice of the shareholders or creditors of the Company, the auditor may require the board of Directors to convene an extraordinary general meeting for the purpose of giving an explanation of the circumstances connected with its resignation.

(d) *Rights of auditors*

The auditor(s) appointed by the Company shall have the right to:

- (i) inspect at any time the books, records and certificates of the Company, and to require the Directors, manager, deputy general manager or other senior officers to provide any relevant information and explanations;
- (ii) require the Company to take all reasonable steps to obtain from its subsidiaries such information and explanations as are necessary for the auditor(s) to perform his duties; and
- (iii) attend shareholders' general meetings, obtain all notices of, and other information relating to, such meetings which shareholders are entitled to receive, and to present its views at any shareholders' general meetings on matters that are of his concern as auditor of the Company.

(8) Notice of meetings and business to be conducted thereat

The shareholders' general meeting is the authority of the Company and its functions and powers shall be exercised in accordance with the law. When the Company convenes a shareholder's general meeting, written notice shall be given not less than 45 days before the date of the meeting to all shareholders registered in the register of shareholders. Such notice shall:

- (i) be given in writing;
- (ii) specify the place, the date and the time of the meeting;
- (iii) set out the date of registration for the shareholdings of the shareholders entitled to attend the meeting;
- (iv) record the standing contact person's name and telephone number;
- (v) state the matters to be considered at the meeting;
- (vi) provide such information and explanation as necessary for the shareholders to make an informed decision on the matters proposed to be considered. Without limitation the generality of the foregoing principle, such information and explanation shall include but without limitation to, where the Company proposes a merger, a repurchase of its shares, reorganisation of its share capital, or restructuring in any other way, the details of the terms of, and the contract (if any) for, the proposed transaction, and the reason for and the effect of such proposal must be properly explained;
- (vii) disclose the nature and extent of the material interests, if any, of any Director, Supervisor, general manager, deputy general manager or other senior officer in a matter to be considered at the general meeting, and the effect of such matter, if any, on the Director, Supervisor, general manager, deputy general manager or other senior officer in his capacity as shareholder in so far as it is different from the effect on other shareholders of the same class;

- (viii) contain the full text of any special resolution proposed to be passed at the general meeting;
- (ix) contain, in conspicuous wording, a statement that a shareholder entitled to attend and vote is entitled to appoint one or more proxies to attend and vote on behalf of him and that a proxy so appointed need not, be a shareholder; and
- (x) specify the time and place for lodging the proxy form(s) for the general meeting.

Notices of shareholders' general meetings shall be served on all shareholders (whether or not they are entitled to vote) by personal delivery or pre-paid post at their addresses registered in the register of shareholders. In respect of holders of Domestic Shares, notices of shareholders' general meetings may also be given by way of a public announcement. The aforesaid public announcement shall be published, within 45 to 50 days prior to the convening of the general meeting, in one or more newspapers specified by CSRC. Once the public announcement is made, all holders of Domestic Shares shall be deemed to have received notice of the relevant shareholders' general meeting. An accidental omission to give notice of a general meeting to any person entitled to receive notice or a failure by such person(s) to receive such notice shall not invalidate that general meeting or any resolution passed at that meeting.

The Company shall give a notice so that those foreign listed shareholders whose registered addresses are in Hong Kong have sufficient time to exercise their rights or act in accordance with the terms of the notice.

The shareholders' general meeting shall have the following functions and powers:

- (i) to determine the operational policies and investment plans of the Company;
- (ii) to elect and replace Directors and to decide matters concerning Directors' remuneration;
- (iii) to elect and replace Supervisor(s) who are representatives of shareholders and independent Supervisor(s) and to decide on matters concerning Supervisors' remuneration;
- (iv) to consider and approve reports of the board of Directors;
- (v) to consider and approve reports of the supervisory committee;
- (vi) to consider and approve the annual financial budgets and final accounts of the Company;
- (vii) to consider and approve proposals for the distribution of the Company's profits and proposals for making up any losses of the Company;
- (viii) to decide on proposals to increase or reduce the registered capital of the Company;
- (ix) to decide on matters concerning the merger, demerger, dissolution and liquidation of the Company;
- (x) to consider and decide on the issue of debt securities by the Company;
- (xi) to examine and approve the Company's share option scheme, management share subscription scheme and other incentive proposals, plans or systems;
- (xii) to decide on the appointment, dismissal or non-renewal of appointment of an auditor;
- (xiii) to amend the Articles of Association;
- (xiv) to consider any resolution(s) proposed by shareholders representing 5% or more of the shares carrying voting rights, and to decide such proposals;

- (xv) to decide on any other matters required by law, administrative regulations or the Articles of Association to be dealt with in a shareholders' general meeting; and
- (xiv) to authorise or appoint the board of Directors to implement the matters so authorised or appointed.

The following matters shall be resolved by way of ordinary resolution of the shareholders' general meeting:

- (i) reports of the board of Directors and the board of Supervisors;
- (ii) profit distribution proposals and proposals for making up losses formulated by the Board;
- (iii) remuneration of the board of Directors and methods of payment;
- (iv) removal of members of the board of Supervisors and their remuneration and methods of payment;
- (v) the Company's financial budgets, audited accounts, balance sheet, profit and loss account and other financial statements;
- (vi) share option scheme, management share subscription scheme and other incentive proposals, plans or systems as formulated by the board of directors; and
- (vii) matters other than those which are required by the laws, regulations and provisions of the Articles of Association to be adopted by a special resolution.

The Articles of Association provide that the following matters may be approved by way of a special resolution of the shareholders' general meeting:

- (i) an increase, reduction and issue of any class of shares, warrants or other similar securities by the Company;
- (ii) repurchase of the Company's shares;
- (iii) an issue of debt securities of the Company;
- (iv) the demerger, merger, dissolution and liquidation of the Company;
- (v) any amendment to the Articles of Association; and
- (vi) any other matters which the shareholders' general meeting has resolved (by way of an ordinary resolution) as having a potentially material effect on the Company, which should be approved by way of a special resolution.

(9) Transfer of shares

Unless otherwise prescribed by law and/or administrative regulations, shares of the Company are freely transferable without any liens. All fully paid up overseas listed foreign shares listed in Hong Kong shall be freely transferable in accordance with the Articles of Association, subject to the right of the board of Directors to refuse recognition of any transfer document, without providing any reason for such refusal, unless and until the following conditions are satisfied:

- (i) payment of a fee of HK\$2.5, or such larger amount as may from time to time be requested by the Board but not more than the amount prescribed by the Listing Rules, to the Company for the registration of any transfer document(s) or other document(s) relating to or affecting the ownership of the shares in question or the change of ownership of those shares;
- (ii) the transfer document relates only to overseas listed foreign shares listed in Hong Kong;
- (iii) payment in full of any stamp duty due on the transfer document;
- (iv) production of the relevant share certificates and any other evidence reasonably required by the board of Directors to prove the transferor's right to make the transfer;
- (v) if the shares are to be transferred to joint holders, the number of joint holders does not exceed four; and
- (vi) the relevant shares of the Company are free from all liens.

Any alteration or rectification of the share register shall be carried out in accordance with the laws of the place where the register is maintained.

Changes in the shareholders' register due to the transfer of shares should not be made within 30 days prior to the shareholders' general meeting or less than 5 days before the record date for the Company's distribution of dividends.

(10) Power of the Company to purchase its own shares

Subject to the approval of the relevant PRC regulatory authorities and to the provisions of the Articles of Association, the Company may repurchase its issued shares in the following circumstances:

- (i) to cancel its shares for the purpose of reducing its share capital;
- (ii) to merge with another company which holds the shares of the Company; or
- (iii) under any other circumstances permitted by law and administrative regulations.

Upon the approval of the relevant PRC regulatory authorities, the Company may repurchase its own shares by one of the following methods:

- (i) by way of a general offer to all shareholders in proportion to their respective shareholdings;
- (ii) repurchase through open trading on a stock exchange; or
- (iii) repurchase through entering into an agreement outside a stock exchange ("off-market agreement").

Where the Company repurchases its own shares by an off-market agreement, it must first obtain the prior approval of the shareholders in general meeting in accordance with the Articles of Association. The Company may rescind, vary or waive its rights under any such contract entered into if the prior approval of the shareholders in general meeting is obtained. A contract to repurchase shares includes, but is not limited to, an agreement to assume an obligation to repurchase or an agreement to acquire rights to repurchase shares of the Company. The Company shall not assign a contract to repurchase its shares nor any of its rights under such a contract. Unless the Company is in liquidation, it shall repurchase its issued shares in accordance with the following provisions:

- (i) where the Company repurchases its shares at par value, payment shall be made out of the available balance of its distributable profits and/or out of the proceeds from any issue of new shares made for the purpose of repurchasing these shares;

- (ii) where the Company repurchases its shares at a premium, payment up to the par value of those shares may be made out of the available balance of the distributable profits of the Company and/or out of the proceeds from any issue of new shares made for the purpose of repurchasing these shares. Payment of the portion in excess of the par value of those shares shall be made as follows:
 - (1) if the shares being repurchased were issued at their par value, payment shall be made out of the available balance of the distributable profits of the Company;
 - (2) if the shares being repurchased were issued at a premium, payment shall be made out of the available balance of the distributable profits of the Company and/or out of the proceeds from any issue of new shares made for the purpose of repurchasing those shares, provided that the amount paid out of the said proceeds does not exceed the aggregate amount of the premiums received by the Company on the issue of the shares being repurchased nor the current amount of the Company's capital reserve fund account (including the aggregate of premiums received on the new shares issued at the time of the repurchase);
- (iii) any payment made by the Company for the following purposes shall be paid out of the Company's distributable profits:
 - (1) to acquire the right to repurchase its own shares;
 - (2) to vary a contract to repurchase its own shares; or
 - (3) to secure the release of any of its obligations under a contract to repurchase its own shares.

Following the deduction of the aggregate par value of cancelled shares from the registered capital of the Company in accordance with the relevant regulations, the amount of distributable profits used for payment of the par value of such shares shall be charged to the capital reserve fund account of the Company.

Share certificates shall take effect after being sealed or impaired with the seal of the Company. The share certificate shall only be sealed with the Company's seal under the authorization of the board of Directors.

(11) Power of any subsidiary of the Company to own shares in its parent

There are no provisions in the Articles of Association relating to ownership of shares in the Company by a subsidiary.

(12) Dividends and other methods of distribution

The Company may distribute dividends in the form of:

- (i) cash; and/or
- (ii) shares.

Cash dividends and other distributions of the Domestic Shares shall be calculated and declared in RMB and shall be paid in RMB within three months after the declaration. Cash dividends and other distributions of H Shares shall be calculated and declared in RMB and paid in Hong Kong dollars within three months after the declaration and in accordance with the PRC rules and regulations governing the control of foreign exchanges. The Company shall appoint (a) receiving agent(s) on behalf of holders of overseas listed foreign shares. The receiving agents shall collect dividends and other monies payable to holders of overseas listed

foreign shares on their behalf in respect of the overseas listed foreign shares held by them. The receiving agent(s) appointed by the Company shall meet the requirements of the laws of the place where the overseas listed foreign shares are listed or other regulations of the relevant securities exchange. A receiving agent appointed by the Company on behalf of the holders of overseas listed foreign shares listed in Hong Kong shall be a trust corporation registered under the Trustee Ordinance of Hong Kong.

(13) Proxies

A shareholder may attend and vote at or appoint a proxy to attend and vote on his behalf at a shareholders' general meeting. Any shareholder entitled to attend and vote at a shareholders' general meeting shall be entitled to appoint one or more persons (whether or not a shareholder) as his proxy or proxies to attend and vote instead of him. The proxy of a shareholder may exercise the following rights in accordance with the authorisation of that shareholder:

- (i) that shareholder's right to speak at the meeting;
- (ii) the right to demand, whether on his own or with others, a poll; and
- (iii) the right to vote on a show of hands or on a poll, but a proxy of a shareholder who has appointed more than one proxy may only vote on a poll.

A shareholder shall appoint a proxy in the form of a written instrument, signed by the appointing shareholder(s) or the agent of the appointing shareholder(s) duly authorised in writing. If the appointing shareholder is a legal person, the legal person's seal or the signature(s) of its director(s) or representative(s) duly authorised in writing is required. The instrument appointing a proxy shall be deposited at the domicile of the Company, or at such other place as prescribed in the notice convening the meeting, either 24 hours before the meeting in question or 24 hours before the time specified for conducting the poll. If the instrument of appointment is signed by a person (other than the appointing shareholder) who is authorised by the appointing shareholder, the power of attorney or other document empowering that person to sign the instrument on behalf of the appointing shareholder must be notarised. The notarised document(s) shall then be deposited, together with the instrument appointing the proxy, at the domicile of the Company or such other place as prescribed in the notice convening the meeting.

The format of any form issued to shareholders by the board of Directors for the purpose of appointing a proxy shall enable a shareholder, according to his free choice, to instruct his proxy to vote in favour of or against each resolution proposed at the meeting. Such a form shall contain a statement that in the absence of instructions from the appointing shareholder(s), the proxy may vote as he thinks fit. If the shareholder of overseas listed foreign shares in the Company is a recognised clearing house, it may authorise any appropriate person(s) as it thinks fit to act as its representative(s) at any shareholders general meeting or any class meeting. If more than one person is so authorised, the instrument of authorisation must clearly state the class(es) and number of shares in respect of which each such person is so authorised. The aforementioned authorised person is entitled to exercise rights on behalf of the recognised clearing house (or its proxy(ies)), as if such person is an individual shareholder of the Company. The vote of a proxy at a general meeting which is in, accordance with the terms of the instrument of his appointment shall be valid notwithstanding the appointing shareholder's death, loss of capacity, revocation of his appointment or the authority under which the instrument of his appointment was executed, or a transfer of the relevant shares, provided that the Company did not receive notice in writing of such event before the commencement of the relevant meeting.

(14) Calls on shares and forfeiture of shares

Any amount paid up in advance of calls on any share may carry interest but shall not entitle the holder of the share to participate in respect thereof in a dividend subsequently declared. Where power is taken to forfeit unclaimed dividends, that power shall not be exercised until after the expiration of the applicable limitation period.

(15) Inspection of register of members

The Company shall maintain a register of shareholders as a record of the following matters:

- (i) the name, address (residential) and occupation/nature of occupation of each shareholder;
- (ii) the class(es) and number of shares of each class held by each shareholder;
- (iii) the amount(s) paid up or payable on the shares held by each shareholder;
- (iv) the serial numbers of the shares held by each shareholder;
- (v) the date on which each person registers to become a shareholder; and
- (vi) the date on which a person ceases to be a shareholder.

The Company shall keep a complete register of shareholders which shall comprise the following parts:

- (i) register(s) maintained at the Company's domicile which shall be the register of all shareholders other than those registered in accordance with sub-paragraphs (ii) and (iii) below;
- (ii) register(s) of holders of overseas listed foreign shares maintained at the place(s) where the stock exchange(s) on which such shares are listed is/are located; and
- (iii) register(s) of shareholders maintained at such other place(s) as the board of Directors may deem necessary for the purpose of listing the Company's shares.

Ordinary shareholders of the Company shall enjoy, inter alia, the right to receive relevant information in accordance with the Articles of Association including:

- (i) to obtain a copy of the Articles of Association upon payment of the cost thereof;
- (ii) to inspect and obtain a copy of, upon payment of a reasonable fee:
 - (1) all parts of the register of shareholders;
 - (2) the personal particulars of each of the Directors, Supervisors, general manager, deputy general manager and other senior officers, including:
 - (a) his present and former name(s) and alias(es);
 - (b) his principal address (residential);
 - (c) his nationality;
 - (d) his main occupation and all his other part-time occupations and positions;
 - (e) his identification document and its number; and
 - (f) financial statements.
- (iii) the status of the Company's share capital;

- (iv) a report showing the aggregate par value, the number and the maximum and minimum prices paid by the Company in respect of each class of the shares repurchased by the Company since the previous financial year, and all expenses paid by the Company for this purpose; and
- (v) minutes of shareholders' general meetings.

(16) Quorum for meetings and separate class meetings

Shareholders who intend to attend a shareholders' general meeting shall deposit at the Company written replies confirming their intention to attend at least 20 days prior to the date of the meeting. The Company shall, according to the written replies received 20 days prior to the general meeting, calculate the number of shares carrying rights to vote represented by the shareholders proposing to attend the meeting. If the number of shares carrying rights to vote represented by shareholders proposing to attend the meeting is more than half of the total number of shares in the Company which carry rights to vote, the Company may proceed to hold the shareholders general meeting; if that number is not reached, the Company shall within 5 days notify the shareholders again of the matters proposed to be discussed at the meeting, the date and venue of the meeting by way of public announcement. After such public announcement is made, the Company may proceed to hold the shareholders general meeting. The above procedure applies, mutatis mutandis, to shareholders of each class of shares in respect of separate class meetings.

(17) Rights of the minorities in relation to fraud or oppression thereof

Apart from the obligations imposed by law, administrative regulations or the listing rules of the stock exchanges on which shares of the Company are listed, a controlling shareholder when exercising his rights as a shareholder shall not, by virtue of the exercise of his voting rights, cause a decision to be made such as to prejudice the interests of all or some shareholders in connection with the following matters:

- (i) to release a Director or Supervisor of his duty to act honestly in the best interests of the Company;
- (ii) to approve an expropriation in any form by a Director or Supervisor (for his own benefit or for the benefit of another person) of the Company's assets including, without limitation, opportunities beneficial to the Company; or
- (iii) to approve an expropriation by a Director or Supervisor (for his own benefit or for the benefit of another person) of the personal rights of other shareholders, including without limitation, rights to distributions and voting rights, but not including a restructuring of the Company submitted to and approved by, shareholders in general meeting in accordance with the Articles of Association.

For these purposes, a controlling shareholder means a person who satisfies any one of the following conditions:

- (i) he, when acting alone or together with others, has the power to elect more than half of the directors;
- (ii) he, when acting alone or together with others, has the power to exercise 30%, or more of the voting rights in the Company or to control the exercise of 30% or more of the voting rights in the Company;
- (iii) he, when acting alone or together with others, holds 30% or more of the issued shares of the Company; or
- (iv) he, when acting alone or together with others, has de facto control of the Company.

(18) Procedures on liquidation

The Company shall be dissolved and liquidated in accordance with law under any one of the following circumstances:

- (i) where the general meeting resolves to dissolve the Company;
- (ii) where dissolution is necessary by reason of merger or demerger of the Company;
- (iii) where the Company is declared insolvent in accordance with law because it is unable to pay its debts as they fall due; and
- (iv) where the Company is ordered to close down by reason of its contravention of law or administrative regulations.

Where the board of Directors decides to liquidate the Company (for reasons other than the insolvency of the Company), the board of Directors shall, in the notice convening a shareholders' general meeting for this purpose, state that, after having made full investigation into the affairs of the Company, it is of the opinion that the Company will be able to pay its debts in full within 12 months from the date of commencement of the Company's liquidation. Upon the passing of a resolution by the shareholders in general meeting to liquidate the Company, the functions and powers of the board of Directors shall cease immediately. If the Company is dissolved pursuant to an event as set out in paragraph (i), a liquidation committee shall be set up within 15 days thereafter, and the composition of the liquidation committee of the Company shall be determined by an ordinary resolution of shareholders in a general meeting. If a liquidation committee is not established according to schedule, creditors of the Company may apply to the people's court to organize the relevant personnel to establish a liquidation committee to proceed the liquidation. If the Company is dissolved pursuant to an event as set out in paragraph (ii), the liquidation shall be conducted by the parties to the merger or demerger in accordance with the contract of or agreement made at the time of merger or demerger. If the Company is dissolved pursuant to an event as set out in paragraph (iii), the people's court shall in accordance with the provisions of relevant laws organize the shareholders, relevant organizations and relevant professional personnel to establish a liquidation committee to proceed the liquidation. If the Company is dissolved pursuant to an event as set out in paragraph (iv), the relevant governing authorities shall organize the shareholders, relevant organizations and professional personnel to establish a liquidation committee to proceed with the liquidation.

The liquidation committee shall notify creditors within 10 days of its establishment and shall make at least 3 public announcements in newspapers within 60 days of its establishment. The liquidation committee shall carry out registration of creditors' rights. After the liquidation committee has administered the assets of the Company and prepared a balance sheet and an inventory of the Company's assets, it shall draw up a proposal for the liquidation and submit the same to the shareholders' general meeting or the relevant supervisory authorities for approval.

The Company's assets shall be liquidated in the order prescribed by the law and regulations. In the absence of such applicable law, such liquidation of assets shall be conducted pursuant to the order, which shall be fair and reasonable as the liquidation committee determines.

Any surplus assets remaining after the above payments have been made in full shall be distributed to the shareholders according to the class(es) and proportion of shares they hold. Upon completion of the liquidation of the Company, the liquidation committee shall prepare a liquidation report and accounts of its income and expenditure and financial reports for the period of the liquidation. Once these accounts and reports are verified by a registered accountant of the PRC, they shall be submitted to the shareholders' general meeting or the relevant supervisory authorities for approval. The liquidation committee shall, within 30 days of the date of approval by the shareholders' general meeting or the relevant supervisory authorities, submit the accounts and reports mentioned above to the companies registration authorities, apply for cancellation of the Company's registration and announce the cessation of the Company.

(19) Other provisions*(a) General provisions and limited liability*

The Company is a joint stock limited company of perpetual duration and was established by way of private subscription. It is an independent enterprise legal person, governed and protected by laws, regulations and other relevant government provisions of the PRC. The capital of the Company is divided into shares of equal par value. The liability of a shareholder to the Company is limited by the shares held by him. The Company shall be liable for its debts up to the extent of all its assets. Upon the approval of the companies supervisory authorities authorised by the State Council, the Company may, in accordance with its operation and management needs, operate as a holding company in accordance with paragraph 2 of Article 12 of the PRC Company Law. The Company may invest in other limited liability companies and joint stock limited companies and accept liability in respect of such companies up to the amount of its investment in such companies. The Company shall not become a partner with unlimited liability of any other economic organisations.

(b) The Articles of Association

The Articles of Association constitute a legally binding document governing the constitution and activities of the Company, the rights and obligations between the Company and its shareholders and the shareholders inter se. The Articles of Association are binding upon the Company and its shareholders, Directors, Supervisors, general manager, deputy general manager and other senior officers. Such persons may bring claims on matters relating to affairs of the Company in accordance with the Articles of Association. Shareholders may bring actions against the Company in accordance with the Articles of Association; the Company may bring actions against shareholders in accordance with the Articles of Association; shareholders may bring actions against other shareholders in accordance with the Articles of Association, and shareholders may bring actions against the Directors, Supervisors, general manager, deputy general manager, and other senior officers of the Company in accordance with the Articles of Association. For the purpose of this paragraph, actions include proceedings commenced in court and arbitration proceedings commenced in arbitration tribunals.

(c) Shares and registered capital

The Company shall at all times have ordinary shares. The Company may, in accordance with its needs and upon obtaining approval by the companies supervisory authorities authorised by the State Council, create other types of shares. Shares issued by the Company shall have a par value. Each share shall have a par value of RMB1.00. The Company may issue shares to either or both domestic investors and foreign investors upon obtaining approval from the securities regulatory authorities of the State Council. For the purpose of the preceding paragraph, "foreign investors" means investors from foreign countries and the territories of Hong Kong, Macau and Taiwan who subscribe for shares issued by the Company; "domestic investors" means investors who subscribe for shares issued by the Company from within the PRC other than from the aforesaid territories.

The shares issued by the Company to domestic investors which are subscribed for in RMB are called "Domestic Shares". The shares issued by the Company to foreign investors which are subscribed for in foreign currencies are called "foreign shares". Foreign shares which are listed outside the PRC are called "overseas listed foreign shares". Pursuant to the approval of the companies supervisory authorities authorised by the State Council, the total number of ordinary shares which may be issued by the Company following its incorporation is 45,000,000 Domestic Shares of RMB1.00 each, of which Sample Group holds 18,000,000 Domestic Shares, Nanjing Zhongbei holds 12,000,000 Domestic Shares, Huadong Technology holds 12,000,000 Domestic Shares, Sample Commerce City holds 1,650,000 Domestic Shares, Nanjing Daily holds 900,000 Domestic Shares and Sha Min (沙敏) holds 450,000 Domestic Shares, respectively representing 40%, 26.67%, 26.67%, 3.66% 2% and 1% of the total registered capital of the Company.

Ordinary Shares issued upon the Company's initial share offering were 20,400,000 overseas listed foreign shares (including 19,500,000 new shares and 900,000 existing shares), representing 31.63% of the total number of issued ordinary shares of the Company. The existing structure of the Company's share capital is as follows: the total number of issued ordinary shares is 64,500,000 shares, out of which 44,100,000 shares representing 68.37% of the total number of issued ordinary shares are held by the promoters; 20,400,000 overseas listed foreign shares representing 31.63% of the total number of issued ordinary shares are held by holders of H Shares.

The board of Directors may make separate arrangements to implement the Company's plan to issue overseas listed foreign shares and Domestic Shares, subject to the prior approval of such plan by CSRC. The Company's plan for separate issues of overseas listed foreign shares and Domestic Shares referred to in the Articles of Association may be implemented separately within 15 months of the date of approval by the CSRC. The overseas listed foreign shares and Domestic Shares, referred to in the Company's aforementioned share issue plan, and shall be fully subscribed in one occasion. Where there are special circumstances which render it impossible for such shares to be fully subscribed in one occasion, separate issues of the shares may be made subject to the approval of CSRC. Upon completion of the issue of shares as described above, the registered capital of the Company will be RMB64,500,000. The Company may in accordance with the provisions of the Articles of Association increase its capital according to its business and development requirements.

The following methods may be used for increasing the capital of the Company:

- (1) by offering new shares to general investors;
- (2) by placing new shares with existing shareholders;
- (3) by a bonus issue of shares to existing shareholders; or
- (4) by any other methods permitted under PRC laws and administrative regulations.

In increasing the capital of the Company through a new issue of shares, the Company shall, after obtaining the necessary approvals in accordance with the Articles of Association, implement such increase in accordance with the procedures prescribed by the relevant PRC laws and administrative regulations.

(d) *The Board of Directors*

The board of Directors is accountable to the shareholders' general meeting and shall have the following functions and powers:

- (i) to convene shareholders' general meetings and to report on its work at shareholders' general meetings;
- (ii) to implement resolutions passed at shareholders' general meetings;
- (iii) to decide the Company's operational plans and investment proposals;
- (iv) to determine the Company's annual financial budgets and final accounts;
- (v) to formulate proposals for distributing the profits of the Company and proposals for making up any losses of the Company;
- (vi) to formulate proposals for an increase or reduction of the Company's registered capital and for the issue of debt securities of the Company;
- (vii) to prepare plans for the demerger, merger or dissolution of the Company;

- (viii) to decide on matters concerning the internal management structure of the Company;
- (ix) to appoint or dismiss the general manager of the Company and, upon the nomination of the general manager, to appoint and dismiss deputy general manager(s) and other senior officer(s) (including financial controller(s)) of the Company and to decide matters concerning the remuneration of such officers; to appoint or replace members of the board(s) of directors and supervisory committee(s) of its wholly-owned subsidiaries, to appoint, replace or nominate shareholder representative(s), director(s) or supervisor(s) of its subsidiaries either controlled or invested by the Company;
- (x) to determine the basic management system of the Company;
- (xi) to formulate proposals for amendments to the Articles of Association;
- (xii) subject to compliance with the requirements of the relevant laws, regulations, the Articles of Association and any relevant rules, to exercise the Company's power to raise capital and to borrow, and to decide on the mortgaging, letting, subcontracting or transfer of the Company's major assets and to delegate such powers to the general manager and deputy general manager for his exercise within certain limits;
- (xiii) subject to the relevant laws, regulations and in light of the actual situations, to formulate share option scheme, management share subscription scheme and other incentive proposals, plans and systems;
- (xiv) to propose in a shareholders' general meeting to engage or replace the accounting firm which undertakes auditing work of the Company;
- (xv) any other functions and powers conferred by shareholders' general meetings and the Articles of Association.

Resolutions passed by the board of Directors in respect of items (iii), (v), (vi), (vii), (ix), (xi) and (xii) above shall be passed by two thirds or more of the board of Directors voting in favour thereof. In respect of other matters, resolutions shall be passed by more than one half of the board of Directors voting in favour thereof. A meeting of the board of Directors shall only be held if more than one half of the Directors are present. Each Director shall have one vote. In the case of an equality of votes, the chairman shall have an additional vote. Board meetings shall be held at least twice every year and shall be convened by the chairman in accordance with the procedures set out in the Articles of Association. In the event of an emergency, extraordinary board meetings may be convened upon a request by two or more Directors or the general manager in accordance with the procedures set out in the Articles of Association.

(e) *Company secretary*

The Company shall appoint a company secretary who shall be a senior officer of the Company. The Directors shall appoint a natural person who has the requisite professional knowledge and experience. The main responsibilities of a company secretary are:

- (i) to ensure that the constitutional documentation and records of the Company are complete;
- (ii) to ensure that the Company prepares and submits all reports and documents required to the relevant authorities in accordance with the law;
- (iii) to ensure that the Company's register of shareholders is properly maintained and that persons entitled to records and documents of the Company are promptly furnished with the relevant records and documents;

- (iv) be responsible for the disclosure of the Company information and to ensure the timely, accurate, legal, true and complete disclosure of the Company information; and
- (v) be responsible for other matters required by the Articles of the Association of the Company and the listing rules of the stock exchange where the shares of the Company are listed.

(f) *Board of Supervisors*

The Company shall have the board of Supervisors which is responsible for the supervision of the board of Directors, the Directors and other senior officers of the Company to prevent them from abusing their positions and powers and infringing the interests of the shareholders, the Company and the employees. The board of Supervisors shall consist of one representative of employees, two external Supervisors and two independent Supervisors, one of whom shall be appointed the chairman of the board of Supervisors. The representative of employees shall be elected and removed by the employees of the Company democratically and the representatives of the shareholders shall be elected and removed by the shareholders' in general meeting. Supervisors shall be appointed for a term of three years from the date(s) of their elections and may be re-elected to serve consecutive terms. The chairman of the board of Supervisors shall be appointed and removed by two-thirds or more of the Supervisors. Decisions of the supervisory committee shall be made by the affirmative vote of two-thirds or more of the Supervisors. The board of Supervisors shall be accountable to the shareholders' general meeting and shall exercise the following functions and powers in accordance with law:

- (i) to examine the Company's financial affairs;
- (ii) to carry out supervision to ensure that the Directors, and other senior officers do not act in contravention of any laws, administrative regulations and for the Articles of Association in the performance of their duties;
- (iii) if the conduct of a Director, or other senior officer is detrimental to the interests of the Company, to require him to rectify such conduct;
- (iv) to review the Company's financial reports, business reports and profit distribution plans which the board of Directors proposes to be submitted to the shareholders' general meeting, and in appropriate cases, to appoint on behalf of the Company registered accountants or practicing auditors to assist in the review;
- (v) to propose the convening of extraordinary general meetings of shareholders;
- (vi) to represent the Company in negotiations with Directors or to institute proceedings against Directors; and
- (vii) other functions and powers provided by the Articles of Association.

Supervisors shall attend board meetings.

(g) *Obligations of Directors, Supervisors, general managers, deputy general managers and senior officers of the Company*

Each Director, Supervisor, general manager, deputy general managers and other senior officer has the duty, in the exercise of his powers and the discharge of his obligations, to exercise such care, diligence and skill that a reasonable and prudent person would exercise in similar circumstances. In addition to the obligations imposed by laws, administrative regulations or the rules of the stock exchanges on which shares of the Company are listed, each Director, Supervisor, general manager,

deputy general manager and other senior officer, when exercising the functions and powers conferred upon him by the Company, owes the following obligations to every shareholder:

- (i) not to cause the Company to operate outside the scope of operations stipulated in its business licence;
- (ii) to act in good faith in the best interests of the Company;
- (iii) not to expropriate in any manner the Company's assets, including (but not limited to) opportunities beneficial to the Company; and
- (iv) not to expropriate personal rights of shareholders, including (but not limited to) distribution rights and voting rights, but not including a restructuring of the Company submitted to and approved by the shareholders' general meeting in accordance with the Articles of Association.

Each Director, Supervisor, general manager, deputy general manager and other senior officer has, in the performance of his duties, the duty to observe the principles of good faith and the duty not to place himself in a position where his duties and his interests may conflict. This includes (but is not limited to) the duty:

- (i) to act honestly in the best interests of the Company;
- (ii) to exercise his powers within the scope of his authority and not act in excess of his powers;
- (iii) to personally exercise the discretion vested in him and not to allow himself to act under the direction of another person and, except where permitted by law or administrative regulations, or with the informed consent of shareholders in general meeting, not to delegate the exercise of such discretion to another person;
- (iv) to treat shareholders of the same class equally and to treat shareholders of different classes fairly;
- (v) not to enter into any contract, transaction or arrangement with the Company, except in accordance with the Articles of Association or with the informed consent of shareholders in general meeting;
- (vi) not to use the Company's assets for his own benefit in any manner without the informed consent of shareholders in general meeting;
- (vii) not to abuse his position by accepting bribes or other unlawful income, and not to expropriate in any manner the Company's assets including (without limitation) opportunities beneficial to the Company;
- (viii) not to accept any commission in connection with any transaction in which the Company is involved without the informed consent of shareholders in general meeting;
- (ix) to comply with the Articles of Association, to perform honestly his duties, to protect the interests of the Company and to refrain from using his position and powers as an officer of the Company to make personal gains;
- (x) not to compete with the Company in any manner without the informed consent of shareholders in general meeting;

- (xi) not to misappropriate the Company's funds or to advance the Company's funds to any other person, not to open any bank account in his own name or any other person's name to deposit any of the Company's assets; not to use the Company's assets to provide guarantee(s) for the debt(s) of any shareholder of the Company or any other individuals; and
- (xii) without the informed consent of shareholders in general meetings; not to disclose any confidential information of the Company acquired by him while in office; not to use such information other than in the interests of the Company; save that he may disclose such information to a court or other governmental authorities in the following circumstances:
 - (a) where such disclosure is required by law;
 - (b) where such disclosure is required in the interests of the public; or
 - (c) where such disclosure is required in the personal interests of the Director, Supervisor, general manager, deputy general manager or other senior officer. A Director, Supervisor, general manager, deputy general manager or other senior officer shall not direct the relevant parties (as described in paragraph (f) above) to do what the Director, Supervisor, or other senior officer himself is prohibited from doing.

(h) *Shareholders' obligations*

A shareholder of the Company is a person who lawfully holds shares of the Company and whose name is entered in the register of shareholders. A shareholder shall enjoy the rights and shall bear the obligations attached to the class(es) and the proportion of shares held by him; shareholders holding the same class of shares shall be entitled to the same rights and shall bear the same obligations. In addition to their right to obtain relevant information in accordance with the Articles of Association as mentioned in section 15 above, an ordinary shareholder of the Company shall enjoy the following rights:

- (i) to receive dividends and other distributions in proportion to the number of shares held by him;
- (ii) to attend and vote or appoint proxies to attend and vote on his behalf at shareholders' general meetings;
- (iii) to supervise the business operations of the Company, to make suggestions or to raise queries;
- (iv) to transfer, assign or pledge his shares in accordance with the applicable laws, administrative regulations and the Articles of Association;
- (v) in the event of the termination or liquidation of the Company, to participate in the distribution of surplus assets of the Company according to the proportion of shares held by him at that time; and
- (vi) other rights conferred by relevant laws and administrative regulations, and the Articles of Association.

No powers shall be taken to freeze or otherwise impair any of the rights attaching to any share by reason only that the person or persons who are interested directly or indirectly therein have failed to disclose their interests to the Company.

A holder of ordinary shares in the Company shall have the following obligations:

- (i) to abide by the Articles of Association;
- (ii) to pay subscription monies in accordance with the shares subscribed by him and to the method of subscription; and
- (iii) other obligations imposed by relevant laws, administrative regulations and the Articles of Association. Save in respect of terms agreed by the subscriber at the time of subscription, a shareholder shall not be liable to subscribe for any further share capital.

The Company may cease to send dividend warrants by post if such warrants have been left uncashed on 2 consecutive occasions. However, such power may be exercised after the first occasion on which such a warrant is returned undelivered.

The Company cannot sell the shares of the untraceable shareholders unless:

- (a) during a period of 12 years at least three dividends in respect of the shares in questions have become payable and no dividend during that period has been claimed; and
- (b) on expiry of the 12 years the issuer gives notice of its intention to sell the shares by way of an advertisement published in the newspapers and notifies the CSRC and the Stock Exchange of such intention.

(i) *Resolution of disputes*

In the event of a dispute or claim involving any rights or obligations provided in the Articles of Association, the Company Law and other relevant laws and administrative regulations, concerning the affairs of the Company, between the following parties:

- (i) a holder of overseas listed foreign shares and the Company;
- (ii) a holder of overseas listed foreign shares and the Directors, Supervisors, general managers, deputy general managers or other senior officers of the Company; and
- (iii) a holder of overseas listed foreign shares and a holder of Domestic Shares, the parties concerned shall submit that dispute or claim to arbitration.

In the event of a dispute or claim referred to above, the claim or dispute must be referred to arbitration in its entirety. All persons (if they are the Company, or shareholders, Directors, Supervisors, general managers, deputy general manager, or other senior officers of the Company) who have a cause of action based on the same facts giving rise to the dispute or claim or whose participation is necessary for the resolution of that dispute or claim shall submit themselves for arbitration. Once an applicant refers a dispute or claim to arbitration, the other party or parties must submit to the arbitral body elected by the applicant. If the party applying for arbitration chooses to refer the matter to the Hong Kong International Arbitration Centre, then any party concerned shall be entitled to request, in accordance with the requirements of the securities arbitration rules of the Hong Kong International Arbitration Centre, for that arbitration to be conducted in Shenzhen. If arbitration is sought to resolve a dispute or claim as described above in the first paragraph of this section, the applicable law shall be the laws of the PRC, unless otherwise provided by law and administration regulations. A decision reached as a result of such arbitration shall be final and conclusive and shall be binding on all parties to the dispute or claim. Disputes over the identities of shareholders or the register of shareholders need not be resolved by a referral to arbitration.

IV. PRC LEGAL MATTERS

Commerce & Finance Law Office, the Company's legal adviser on PRC law has sent to the Company a letter dated 2 June 2004 confirming that it has reviewed the summaries of PRC company and securities regulations and the summaries of certain material differences between Hong Kong company law and the Company Law in so far as they relate to PRC law as contained in this Appendix and that, in its opinion, such summaries are correct summaries of relevant PRC laws and regulations. This letter is available for inspection as referred to in the paragraph headed "Documents available for inspection" in Appendix VIII to this prospectus.

I. FURTHER INFORMATION ABOUT THE COMPANY

I. Incorporation

The Company was converted into a joint stock limited company in the PRC on 29 December 2000 with Sample Group, Nanjing Zhongbei, Huadong Technology, Sample Commerce City, Nanjing Daily and Sha Min (沙敏) as Promoters. Upon the conversion, the registered capital of the Company was RMB45,000,000 divided into 45,000,000 Domestic Shares of RMB1.00 each. Such Domestic Shares were paid up and held by the Promoters as follows:

Name of Promoter	Number of Domestic Shares held	Approximate percentage of registered capital (%)
Sample Group	18,000,000	40.00
Nanjing Zhongbei	12,000,000	26.67
Huadong Technology	12,000,000	26.67
Sample Commerce City	1,650,000	3.66
Nanjing Daily	900,000	2.00
Sha Min (沙敏)	450,000	1.00
Total:	<u>45,000,000</u>	<u>100.00</u>

The Company has established a place of business in Hong Kong at Rooms 3705 to 3706, 37th Floor, Gloucester Tower, The Landmark, Central, Hong Kong and has been registered as an oversea company in Hong Kong in compliance with Part XI of the Companies Ordinance on 7 April 2004. Ms. Chan Wei Wei (陳慧慧) of Room 1503, 15/F., Wayson Commercial Building, 28 Connaught Road West, Hong Kong has been appointed as the agent of the Company for the acceptance of service of process in Hong Kong.

Since the Company was established in the PRC, it is required to comply with the laws and regulations of the PRC. A summary of the relevant laws and regulations of the PRC and a summary of Articles of Association are set out in Appendix VI to this prospectus.

The establishment of the Company involved, among other matters, the following procedures and approvals:

- (1) a general meeting of Sample Computer Technology was held on 12 October 2000 approving, among other things, the conversion of Sample Computer Technology from a limited liability company to a joint stock limited company with a registered capital of RMB45 million based on net asset conversion rate of 1:1;
- (2) the Nanjing City People's Government issued a document "市政府關於同意南京三寶計算機科技有限公司變更為南京三寶科技股份有限公司的批覆" (寧政覆[2000]119號) (An approval of the City People's Government regarding the conversion of Sample Computer Technology to the Company (Ning Zhen Fu [2000] No. 119)) on 28 December 2000, agreeing the conversion of Sample Computer Technology from a limited liability company to a joint stock limited company in the Company's name;

- (3) an inaugural general meeting of the Company was held on 29 December 2000 at which, among other matters, the following resolutions were passed:
 - (i) the adoption of the articles of association of the Company (draft); and
 - (ii) the appointment of Sha Min (沙敏), Mr. Chang (常勇), Mr. Guo (郭亞軍), Zhao Jing Cheng (趙竟成), Zhang Yin Qian (張銀千), Zhao Wen (趙文), Zhu De Xian (朱德祥), Zhang Zhan (張展) and Huang Wei (黃衛) as Directors and Mr. Sun (孫懷東), Tian Tao (田濤) and Ms. Du (杜瑾) as Supervisors; and
- (4) the Company was granted the business licence (registration number: 3201002004531) on 29 December 2000 by the Nanjing Administration for Industry and Commerce (南京市工商行政管理局);

2. Shareholders' resolutions, undertakings and approvals in chronological order

The following shareholders' resolutions were passed and approvals were obtained in connection with, among other things, the listing of the Company:

- (1) an annual general meeting for the year 2000 was held on 26 February 2001 approving, among other things, the change of the registered address of the Company to Room 103, Building No.1, Ruan Jian Chuang Ye Zhong Xin, High Technology Development Region, Nanjing City, Jiangsu, the PRC;
- (2) an extraordinary general meeting of the Company was held on 10 November 2001 at which, among other matters, the following resolutions were passed:
 - (i) the acquisition of additional equity interest in Sample Information System Engineering by the Company from Sample Group so that the ultimate equity interest of the Company in Sample Information System Engineering became 80%; and
 - (ii) the removal of Huang Wei (黃衛) from the position of independent Director and the appointment of Wang Wei (王煒) as an independent Director;
- (3) an extraordinary general meeting of the Company was held on 18 February 2003 at which, among other matters, the following resolutions were passed:
 - (i) the listing of the H Shares on GEM be approved;
 - (ii) authority be granted to the Board (a) to handle and obtain all the relevant government approvals and approve and, where appropriate, make amendments to the terms of the agreements and documents in connection with the listing; and (b) to authorise Director to execute such documents;
 - (iii) the increase of registered capital of the Company pursuant to the listing of the Company be approved;
 - (iv) the articles of association of the Company in compliance with the Mandatory Provisions be approved;
 - (v) the Board be authorised to make the necessary and appropriate amendments to the articles of association of the Company in accordance with opinions from the Stock Exchange or other relevant authorities; and
 - (vi) subject to the approval of the CSRC, the subdivision of the shares of the Company of RMB1.00 each into 10 shares of RMB0.10 each be approved and that corresponding amendments be made to the articles of association of the Company;
- (4) an annual general meeting for the year 2002 was held on 18 February 2003 approving, among other matters, the granting of an over-allotment option to the Sponsor;

- (5) an extraordinary general meeting of the Company was held on 27 August 2003 at which, among other matters, the following resolutions were passed:
- (i) the proposal in relation to the subdivision of share of the Company of RMB1.00 each into 10 shares of RMB0.10 each be cancelled and the nominal value of each share of the Company be remained as RMB1.00;
 - (ii) the number of Supervisors be increased to five and that Dai Jian Jun (戴建軍) and Ma Lin Ping (馬林萍) be appointed as independent Supervisors and that the articles of association of the Company be amended accordingly;
 - (iii) the number of Directors be increased to ten and that Lau Shek Yau John (劉石佑) be appointed as an independent non-executive Director and that the articles of association of the Company be amended accordingly;
 - (iv) the appointment of Chan Wei Wei (陳慧慧) as the qualified accountant and company secretary of the Company be approved;
 - (v) the appointment of Guo Ya Jun (郭亞軍) as the compliance officer of the Company be approved;
 - (vi) the establishment of the audit committee of the Company which comprises three members who are all independent non-executive Directors be approved;
 - (vii) the appointment of Guo Ya Jun (郭亞軍) and Chan Wei Wei (陳慧慧) as the authorised representatives of the Company be approved;
 - (viii) the cancellation of the over-allotment option which was proposed to be granted to the Sponsor by the Company be approved; and
 - (ix) the proposed amendments to the articles of association of the Company to reflect the changes as a result of the passing of the resolutions of the same date be approved;
- (6) the approval document (證監國合字[2004]11號) was issued on 26 March 2004 by the CSRC, approving the issue of H Shares by the Company and the listing of H Shares on GEM. The New H Shares and Sale H Shares are foreign listed shares and ordinary shares of the Company;
- (7) an extraordinary general meeting of the Company was held on 24 April 2004 at which, among others, the following resolutions were passed:
- (i) that the Articles of Association, which shall replace the existing articles of association of the Company and shall come into effect on the Listing Date, be approved, and authority be granted to the Board to make any necessary amendment to the Articles of Association in accordance with the requirements of the relevant authorities, including the CSRC and the Stock Exchange;
 - (ii) conditional upon (1) the GEM Listing Committee granting the listing of, and permission to deal in, the Placing Shares (and the H Shares which may be issued upon the exercise of any options granted under the Share Option Scheme) on GEM; (2) the CSRC approving the issue and listing of the H Shares; and (3) the obligations of the Placing Underwriters under the Placing and Underwriting Agreement becoming unconditional (including, where applicable, any conditions waived by the Placing Underwriters) and the Placing and Underwriting Agreement not being terminated in accordance with its terms, the Placing be approved and the Directors be authorised to allot and issue the Placing Shares pursuant thereto;

- (iii) upon completion of the Placing, the registered capital of the Company be increased from RMB45 million to RMB64.5 million;
- (iv) the appointment of Sha Min (沙敏), Chang Yong (常勇) and Guo Ya Jun (郭亞軍) as executive Directors; Zhao Jing Cheng (趙竟成), Zhang Yin Qian(張銀千), Zhao Wen (趙文) and Zhu De Xiang (朱德祥) as non-executive Directors; and Zhang Zhan (張展), Wang Wei (王煒) and Lau Shek Yau John (劉石佑) as independent non-executive Directors be approved, confirmed and ratified and the terms of service contract of each of the Directors and their respective remuneration be approved;
- (v) the appointment of Tian Tao (田濤), Sun Huai Dong (孫懷東) and Du Jin (杜瑾) as Supervisors; and Dai Jian Jun (戴建軍) and Ma Lin Ping (馬林萍) as independent Supervisors be approved, confirmed and ratified and the terms of service contract of each of the Supervisors and their respective remuneration be approved;
- (vi) the terms of the service contract of company secretary and qualified accountant with Chan Wei Wei (陳慧慧) be approved, confirmed and ratified and the remuneration contained therein be approved; and
- (vii) the Share Option Scheme be approved and the Directors be authorised to grant options to subscribe for H Shares in accordance with the terms of the Share Option Scheme and to allot, issue and deal with H Shares upon the exercise of any options by the grantees pursuant to the Share Option Scheme.

3. Changes in share capital and shareholding structure

Set out below are the changes in the share capital and shareholding structure of the Company since its establishment:

Date:	30 December 1997	28 February 2000	10 August 2000	29 December 2000		
Particulars:						Approximate percentage of shareholding immediately after the completion of the Placing (without taking into account any Shares which may fall to be issued upon the exercise of any options granted under the Share Option Scheme)
	Establishment of Sample System (RMB)	Transfer of equity interests and increase of registered capital (RMB)	Transfer of equity interests (RMB)	Conversion of Sample Computer Technology to the Company (RMB) (Note)	Completion of the Placing (without taking into account any Shares which may fall to be issued upon the exercise of any options granted under the Share Option Scheme) (RMB)	Approximate percentage of shareholding immediately after the completion of the Placing (without taking into account any Shares which may fall to be issued upon the exercise of any options granted under the Share Option Scheme) (%)
Shareholding Structure:						
Hu Jia Yong (胡家永)	2,000,000	-	-	-	-	-
Qi Tong Lin (祁同林)	1,000,000	-	-	-	-	-
Sample Group	1,000,000	16,470,000	15,200,000	18,000,000	18,000,000	27.91
Sample Commerce City	1,000,000	1,390,000	1,390,000	1,650,000	1,650,000	2.56
Sha Min (沙敏)	-	380,000	380,000	450,000	450,000	0.70
Nanjing Zhongbei	-	19,760,000	10,135,000	12,000,000	12,000,000	18.60
Huadong Technology	-	-	10,135,000	12,000,000	12,000,000	18.60
Nanjing Daily	-	-	760,000	900,000	-	-
H Shares:	-	-	-	-	20,400,000	31.63
Total:	<u>5,000,000</u>	<u>38,000,000</u>	<u>38,000,000</u>	<u>45,000,000</u>	<u>64,500,000</u>	<u>100.00</u>

Note: RMB1.00 per Share

4. Changes in the Directors and Supervisors

Set out below are the changes in the Directors and the Supervisors since the establishment of the Company:

南京三寶計算機系統工程有限公司

Nanjing Sample Computer System Engineering Company Limited

Date	Directors	Supervisors
15 December 1997	Chang Yong (常勇)	Qi Tong Lin (祁同林) Hu Jia Yong (胡家永)

南京三寶計算機科技有限公司

Nanjing Sample Computer Technology Company Limited

Date	Directors	Supervisors
10 December 1999	Sha Min (沙敏) Chang Yong (常勇) Guo Ya Jun (郭亞軍) Wang Yi (王毅) Zhao Wen (趙文)	Sun Huai Dong (孫懷東) Du Jin (杜瑾) Guan Wei Guo (關衛國)
30 July 2000	Sha Min (沙敏) Chang Yong (常勇) Guo Ya Jun (郭亞軍) Zhao Jing Cheng (趙竟成) Zhao Wen (趙文)	Tian Tao (田濤) Sun Huai Dong (孫懷東) Du Jin (杜瑾)

南京三寶科技股份有限公司

Nanjing Sample Technology Company Limited

Date	Directors	Supervisors
29 December 2000	Sha Min (沙敏) Chang Yong (常勇) Guo Ya Jun (郭亞軍) Zhao Jing Cheng (趙竟成) Zhang Yin Qian (張銀千) Zhao Wen (趙文) Zhu De Xiang (朱德祥) Zhang Zhan (張展) Huang Wei (黃衛)	Tian Tao (田濤) Sun Huai Dong (孫懷東) Du Jin (杜瑾)
10 November 2001	Sha Min (沙敏) Chang Yong (常勇) Guo Ya Jun (郭亞軍) Zhao Jing Cheng (趙竟成) Zhang Yin Qian (張銀千) Zhao Wen (趙文) Zhu De Xiang (朱德祥) Zhang Zhan (張展) Wang Wei (王煒)	Tian Tao (田濤) Sun Huai Dong (孫懷東) Du Jin (杜瑾)

Date	Directors	Supervisors
27 August 2003	Sha Min (沙敏) Chang Yong (常勇) Guo Ya Jun (郭亞軍) Zhao Jing Cheng (趙竟成) Zhang Yin Qian (張銀千) Zhao Wen (趙文) Zhu De Xiang (朱德祥) Zhang Zhan (張展) Wang Wei (王煒) Lau Shek Yau John (劉石佑)	Tian Tao (田濤) Sun Huai Dong (孫懷東) Du Jin (杜瑾) Dai Jian Jun (戴建軍) Ma Lin Ping (馬林萍)

Save as disclosed above, there has been no change in the Directors and Supervisors since the establishment of the Company.

II. SUBSIDIARIES

As at the Latest Practicable Date, the Company has the following subsidiaries:

I. Nanjing Sample Information System Engineering Company Limited (南京三寶信息系統工程有限公司)

Shareholding structure	: The Company and Sample Group are interested in 80% and 20% of the registered capital respectively
Registered capital	: RMB22,000,000 (At the time of establishment of Sample Information System Engineering, its registered capital was fully paid up by Huadong Electronics on 26 January 2000 and by the Company on 31 January 2000 and 29 February 2000 respectively.)
Shareholding interest of the Company	: 80%
Directors	: Sha Min (沙敏), Chang Yong (常勇), Guo Ya Jun (郭亞軍)
Term of operation	: From 11 March 2000 to 10 March 2020
Registered address	: No. 454 Zhu Jiang Road, Nanjing City (南京市珠江路454號)
Scope of business	: Computer network, supervision, design and implementation of industrial automation project; development, manufacture, and sales of electronic products, computer softwares, telecommunications products (excluding satellite ground reception equipment) and computer technical advice and information services.

2. Nanjing Golden Dragon Software Company Limited (南京金龍軟件有限公司)

Shareholding structure	:	The Company and Qi Tong Lin(祁同林) are interested in 95% and 5% of the registered capital respectively
Registered capital	:	RMB6,000,000 (At the time of establishment of Golden Dragon Software, its registered capital was fully paid up by the Company and Qi Tong Lin (祁同林) on 5 November 2001 and 2 November 2001 respectively.)
Shareholding interest of the Company	:	95%
Directors	:	Sha Min (沙敏), Chang Yong (常勇), Qi Tong Lin(祁同林)
Term of operation	:	From 7 November 2001 to 6 November 2021
Registered address	:	Ma Qun Ke Ji Yuan, Qixia District, Nanjing City (南京市栖霞區馬群科技園)
Scope of business	:	Computer network, system integration, design of industrial automation project; development, manufacture, and sales of electronic products, computers and softwares, telecommunications products (excluding satellite ground reception equipment) and computer technical advice and information services.

III. FURTHER INFORMATION ABOUT DIRECTORS, SUPERVISORS, MANAGEMENT, STAFF AND SUBSTANTIAL SHAREHOLDER

I. Directors and Supervisors

(1) Particulars of service contracts and remuneration of Directors and Supervisors

Each of the Directors and Supervisors has entered into a service contract (“Service Contract”) with the Company. Particulars of these contracts, except as indicated, are in all material respects identical and are set out below:

- (i) each Service Contract is for an initial term of three years and may be renewed thereafter subject to the Shareholders’ approval at general meeting of the Company;
- (ii) the annual salary and allowance of each of the Directors and Supervisors under the Service Contract and, where applicable, labour contract (“Labour Contract”) required to be entered into under the PRC laws with the Company, and other emoluments are as follows:

Executive Director	Annual salary and allowance under the Service Contract	Annual salary and allowance under the Labour Contract and other emoluments
Sha Min (沙敏)	RMB100,000	Approximately RMB200,000(Note)
Chang Yong (常勇)	RMB50,000	Approximately RMB150,000
Guo Ya Jun (郭亞軍)	RMB50,000	Approximately RMB150,000
Non-executive Director		
Zhao Jing Cheng (趙竟成)	RMB10,000	—
Zhang Yin Qian (張銀千)	RMB10,000	—
Zhao Wen (趙文)	RMB10,000	—
Zhu De Xiang (朱德祥)	RMB10,000	—
Independent Non-executive Director		
Zhang Zhan (張展)	RMB10,000	—
Wang Wei (王煒)	RMB10,000	—
Lau Shek Yau John (劉石佑)	HK\$60,000	—
Supervisor		
Tian Tao (田濤)	RMB10,000	—
Sun Huai Dong (孫懷東)	RMB10,000	—
Du Jin (杜瑾)	RMB10,000	Approximately RMB100,000
Dai Jian Jun (戴建軍)	RMB10,000	—
Ma Lin Ping (馬林萍)	RMB10,000	—

Note: Sha Min (沙敏) receives an annual salary and allowance of approximately RMB200,000 as legal representative of the Company. As advised by the Directors, as it is not required under PRC laws for legal representative to enter into Labour Contract with the Company, Sha Min (沙敏) did not enter into any Labour Contract with the Company.

- (iii) subject to resolution passed at shareholders' meeting of the Company, the remuneration of the executive Directors and Supervisors may be changed; and
- (iv) each of the Directors and Supervisors is entitled to out-of-pocket expenses reasonably incurred during his/her term of office.

The aggregate annual remuneration payable to the Directors and Supervisors under the Service Contracts are approximately RMB324,000 and RMB50,000 respectively for an initial term of three years.

The aggregate basic salaries and allowances paid to the Directors and Supervisors for the year ended 31 December 2003 are RMB378,000 and RMB75,000 respectively. It is estimated that the aggregate basic salaries and allowances payable to the Directors and Supervisors for the year ending 31 December 2004 will be approximately RMB824,000 and RMB150,000 respectively.

Save as disclosed above, the Company does not currently pay any other remuneration to the executive Directors and therefore there is no current policy regarding such remuneration.

- (2) Disclosure of the Directors' and Supervisors' interests or short positions in the registered capital of the Company and its associated corporation

Immediately following the completion of the Placing (without taking into account any Shares which may fall to be issued upon the exercise of any option granted under the Share Option Scheme), the interest or short positions of the Directors, Supervisors or chief executive of the Company in Shares, debentures or underlying shares of the Company and its associated corporations (within the meaning of Part XV of the SFO) which will be required to be notified to the Company and the Stock Exchange pursuant to Divisions 7 and 8 of Part XV of the SFO (including interests or short positions which are taken or deemed to have under such provisions of the SFO) or which will be required, pursuant to section 352 of the SFO, to be entered in the register referred to therein, or which will be required pursuant to rules 5.46 to 5.67 of the GEM Listing Rules relating to securities transactions by Directors or Supervisors or chief executive, to be notified to the Company and the Stock Exchange once the H Shares are listed, will be as follows:

Interests of Directors and Supervisors in the Company

Name of Director/ Supervisor	Capacity	Number of Domestic Shares	Approximate percentage of the registered capital of the Company immediately after the completion of the Placing (without taking into account any Shares which may fall to be issued upon the exercise of any options granted under the Share Option Scheme) (%) (Note 1)
Sha Min (沙敏)	beneficial owner	450,000	0.7

Notes:

- Unless otherwise stated, all securities are long positions held by such persons.
- Du Yu (杜予) is deemed to be interested in the 450,000 Domestic Shares held by Sha Min (沙敏) under Part XV of the SFO as she is the spouse of Sha Min (沙敏).

2. Shareholders

So far as the Directors are aware, immediately after the completion of the Placing (without taking into account any Shares which may fall to be issued upon the exercise of any option granted under the Share Option Scheme), the following persons (other than a Director or a Supervisor) will have interests or short positions in the Shares, debentures or underlying shares of the Company which would fall to be disclosed to the Company under the provisions of Divisions 2 and 3 of Part XV of the SFO, or will be directly or indirectly interested in 10% or more of the nominal value of any class of share capital carrying rights to vote in all circumstances at general meetings of the Company:

Name of Shareholder	Number of Domestic Shares	Nature of interest	Approximate percentage of registered capital of the Company immediately after the completion of the Placing (without taking into account any Shares which may fall to be issued upon the exercise of any options granted under the Share Option Scheme) (%) (Note 1)
Sample Group (Note 2)	19,650,000	Beneficial and corporate	30.47
Nanjing Zhongbei	12,000,000	Beneficial	18.60
Huadong Technology	12,000,000	Beneficial	18.60
Nanjing Huadong Electronic Group Company (南京華東電子集團公司)(Note 3)	12,000,000	Corporate	18.60

Notes:

1. Unless otherwise stated, all securities are long positions held by such persons.
2. Sample Group directly holds 18,000,000 Domestic Shares and is also interested in 95% of the registered capital of Sample Commerce City, which in turn is directly interested in 1,650,000 Domestic Shares. Pursuant to section 316 of the SFO, Sample Group is deemed to be interested in the 1,650,000 Domestic Shares held by Sample Commerce City.
3. Pursuant to section 316 of the SFO, Nanjing Huadong Electronic Group Company (南京華東電子集團公司) is deemed to be interested in 12,000,000 Domestic Shares held by Huadong Technology as Nanjing Huadong Electronic Group Company (南京華東電子集團公司) is interested in 45.20% of the registered capital of Huadong Technology as at 31 December 2003 according to its 2003 annual report.

3. Related party transactions

The Company had entered into certain related party transactions during the three years ended 31 December 2003 as set out in section F note 27 under the paragraph headed "Related party transactions" in the accountants' report set out in Appendix I to this prospectus.

4. Disclaimers





Save as disclosed herein:

- (i) none of the Directors, chief executive nor Supervisors has any interest or short positions in the equity or debt securities of the Company or any of its associated corporation (within the meaning of the SFO) which, once the H Shares are listed, will be required to be notified to the Company and the Stock Exchange pursuant to section 347 of the SFO (including interests or short positions which they are deemed or taken to have under section 344 or 345 of the SFO), or which will be required, pursuant to section 352 of the SFO, to be entered into the register referred to therein or which will be required, pursuant to rules 5.46 to 5.67 of the GEM Listing Rules relating to securities transactions by director to be notified to the Company and the Stock Exchange once the H Shares are listed and in case of Supervisors, which will be required to be notified as described above if they had been Directors;
- (ii) so far as is known to any of the Directors or Supervisors, there is no person who will, immediately following the completion of the Placing (without taking into account any Shares which may fall to be issued upon the exercise of any option granted under the Share Option Scheme), directly or indirectly have interests or short positions in the Shares or underlying Shares which would fall to be disclosed to the Company pursuant to the provisions of Divisions 2 and 3 of Part XV of the SFO, or, who will be expected, directly or indirectly, to be interested in 10% or more of the nominal value of any class of share capital carrying rights to vote in all circumstances at general meetings of any other member of the Group;
- (iii) none of the Directors nor Supervisors has entered or has proposed to enter into any service contracts with the Company (other than contracts expiring or determinable by the employer within one year without payment of compensation other than statutory compensation);
- (iv) none of the Directors nor Supervisors nor any of the experts whose names are listed in the paragraph headed "Consents of experts" in this appendix has any direct or indirect interest in the promotion of, or in any assets which have been acquired or disposed of by or leased to the Company within the two years immediately preceding the date of this prospectus, or which are proposed to be acquired or disposed of by or leased to the Company;
- (v) none of the Directors nor Supervisors nor any of the experts whose names are listed in the paragraph headed "Consents of experts" in this appendix is materially interested in any contract or arrangement subsisting at the date of this prospectus which is significant in relation to the business of the Company;
- (vi) none of the experts whose names are listed in the paragraph headed "Consents of experts" in this appendix has any shareholding in the Company or the right (whether legally enforceable or not) to subscribe for or to nominate other persons to subscribe for securities in the Company.

IV. FURTHER INFORMATION ABOUT THE BUSINESS

I. Summary of material contracts

The following contracts (not being contracts entered into in the ordinary course of business) have been entered into by the Company within the two years preceding the date of this prospectus and are or may be material upon the listing of the Company:

- (1) the Option Agreement between Sample Group and the Company pursuant to which Sample Group irrevocably granted the Transfer Option to the Company exercisable from the date of the signing of the Option Agreement to 31 July 2008 ("Option Period"). During the Option Period, the Company may, by written notice, exercise the Transfer Option and request Sample Group to transfer the trademark "神保" to the Company at nil consideration. It was further agreed that save for the tax required to be paid due to the transfer of the trademark "神保", which shall be paid by the parties in accordance with PRC laws, rules and regulations, the Company is not required to bear any costs in relation to the execution and performance of the Option Agreement, the exercise of the Transfer Option and the transfer of the trademark "神保". Sample Group shall bear the reasonable costs arising from the exercise of the Transfer Option and the transfer of the trademark "神保";
- (2) the Supplemental Agreement between Sample Group and the Company pursuant to which:
 - (i) since the Company has registered and obtained the domain name "www.sampletech.cn", the parties agreed to terminate the use by the Company of the domain name "www.samples.com.cn" under the Licence Agreement;
 - (ii) the Company shall use the trademarks " " and "神保" at nil consideration for the period from 1 January 2001 to 31 July 2008 ("licence period") in accordance with the Licence Agreement. The licence period will be terminated upon the completion of the transfer of the trademark "神保" if the Company exercises the Transfer Option pursuant to the Option Agreement;
 - (iii) unless otherwise agreed by both parties in writing, the licences granted by Sample Group to the Company for the use of the trademarks " " and "神保" at nil consideration from 1 January 2001 is irrevocable;
 - (iv) the Company shall use the trademarks " " and "神保" within the scope of approved services in the trademark registration certificate nos. 1223813 and 1223880. Sample Group shall obtain prior written consent from the Company if any amendments to such scope of approved services are to be made. Sample Group shall not transfer the trademarks " " and "神保" to any third party before the termination of the Supplemental Agreement. After the termination of the Supplemental Agreement, if Sample Group intends to transfer the trademarks " " and "神保", the Company shall have a pre-emptive right to acquire the same under the same terms and conditions. The transfer of the trademark "神保" is subject to the terms of the Option Agreement; and
 - (v) Sample Group agreed that during the licence period, the Company has the exclusive right to use the trademark "神保". Sample Group shall not continue to use this trademark itself or license the same to any third party.

- (3) the Placing and Underwriting Agreement;
- (4) the deed of indemnity dated 2 June 2004 executed by each of Sample Group, Nanjing Zhongbei, Huadong Technology, Sample Commerce City and Sha Min (沙敏) (the "Indemnifiers") in favour of the Company pursuant to which the Indemnifiers have agreed to indemnify the Company against tax and other liabilities; and
- (5) the sponsor's agreement dated 2 June 2004 entered into between the Company and CPY as required by Rules 6.01, 11.09 and 17.81 of the GEM Listing Rules.





2. Intellectual property rights

- (1) Trademark (and service trademark)

Pursuant to the Licence Agreement and the Supplemental Agreement, Sample Group agreed to grant a licence to the Company to use the following trademarks registered in the name of Sample Group in the PRC at nil consideration:

Mark	Trademark Registration No.	Registered Owner	Effective Period	Class (Note)	Term of licence
1. 	1223813	Sample Group	From 14 November 1998 to 13 November 2008	42	From 1 January 2001 to 31 July 2008
2. 神保	1223880	Sample Group	From 14 November 1998 to 13 November 2008	42	From 1 January 2001 to the earlier of (i) 31 July 2008; and (ii) the date when the transfer of the trademark was completed pursuant to the exercise of the Transfer Option under the Option Agreement

Note: Services included in class 42 include computer rental, computer programming, computer software design, updating of computer software, rental of computer software, consultancy in the field of computer hardware, leasing access time to computer database.

Pursuant to the Licence Agreement, Sample Group agreed to grant a licence to the Company for the use of, inter alia, the trademarks “” and “神保” at nil consideration with effect from 1 January 2001. Pursuant to the Supplemental Agreement, Sample Group irrevocably agreed to grant a licence to the Company for, inter alia, (i) the use of the trademark “”; and (ii) the exclusive use of the trademark “神保” within the scope of approved services in the trademark registration certificate nos. 1223813 and 1223880 (i.e. class 42) at nil consideration. The licence period for (i) commenced on 1 January 2001 until 31 July 2008 whilst the licence period for (ii) commenced on 1 January 2001 until the earlier of (a) 31 July 2008; and (b) the date when the necessary procedures for the transfer of the trademark have been completed pursuant to the exercise of the Transfer Option under the Option Agreement. Under the Supplemental Agreement, Sample Group retains the right to use the trademark “” in connection with services included in class 42 and the Company was granted a pre-emptive right to acquire the trademarks “” and “神保” should Sample Group intend to transfer the same to third parties under the same terms and conditions after the expiry of the Supplemental Agreement.

Sample Group and the Company entered into the Option Agreement pursuant to which Sample Group agreed to grant the Transfer Option to the Company exercisable from the date of signing of the Option Agreement to 31 July 2008 (“Option Period”). During the Option Period, the Company may, by written notice, request Sample Group to transfer the trademark “神保” to the Company at nil consideration. It was further agreed that save for the tax required to be paid for the transfer of the trademark “神保”, which shall be paid by the parties in accordance with PRC laws, rules and regulations, the Company is not required to bear any costs in relation to the execution and performance of the Option Agreement, the exercise of the Transfer Option and the transfer of the trademark “神保”. It is the intention of the Directors to exercise the Transfer Option upon listing of the H Shares on GEM.

The Directors confirm that if the Group is going to use any of the abovementioned trademarks in the future, it will comply with the connected transaction requirements under the GEM Listing Rules.

(2) Copyright

As at the Latest Practicable Date, the relevant member of the Group had registered the following copyrights:

Copyright	Registered owner	Certificate no.	Registration no.	Commencement date
海關關口自動查驗系統VI.0 Customs Checkpoint Automatic Inspection System VI.0	The Company	軟著登字第 0008275號	2001SR1342	1 January 2000
公路車輛監測與記錄系統VI.0 Highway Vehicle Monitoring and Recording System VI.0	The Company	軟著登字第 0008276號	2001SR1343	1 August 1998
金龍公路車輛監測數據管理 軟件VI.0 Golden Dragon Highway Vehicle Monitoring and Data Management Software VI.0	Golden Dragon Software	軟著登字第 004153號	2002SR4153	10 March 2002
金龍海關關口監控軟件VI.0 Golden Dragon Customs Checkpoint Monitoring Software VI.0	Golden Dragon Software	軟著登字第 004154號	2002SR4154	10 March 2002
金龍多媒體展示軟件VI.0 Golden Dragon Multi-media Display Software VI.0	Golden Dragon Software	軟著登字第 012706號	2003SR7615	10 March 2002
金龍起訴業務管理軟件VI.0 Golden Dragon Prosecution Business Management Software VI.0	Golden Dragon Software	軟著登字第 013694號	2003SR8603	10 March 2002
金龍司法監控管理軟件VI.0 Golden Dragon Justice Monitoring Management Software VI.0	Golden Dragon Software	軟著登字第 013695號	2003SR8604	10 April 2002
金龍公路車輛違章監測軟件 VI.0 Golden Dragon Highway Vehicles Rule-violation Monitoring Software VI.0	Golden Dragon Software	軟著登字第 013696號	2003SR8605	10 March 2002
金龍違章車輛處罰管理軟件 VI.0 Golden Dragon Rule-violation Vehicle Penalty Management Monitoring Software VI.0	Golden Dragon Software	軟著登字第 013697號	2003SR8606	10 April 2002

(3) Patent

As at the Latest Practicable Date, the Company was the registered owner of the following patents:

Name of patent	Registered owner	Registration no.	Commencement date
工業室外機櫃 Industrial Outdoor Cabling Rack	The Company	ZL 03 3 16579.3	10 December 2003
多自由度攝像機安裝法蘭盤 Multi-dimensional Image Recorder Flange Plate	The Company	ZL 03 2 20057.9	14 April 2004

As at the Latest Practicable Date, the Company had applied for registration of the following patents:

Name of patent	Name of applicant	Application no.	Application date
工業室外溫控機櫃 Industrial Outdoor Cabling Rack with Temperature Control	The Company	03222018.9	22 May 2003
複合式閃光照明燈 Multi-flashing Lights	The Company	03222019.7	22 May 2003
出租車圖像報警記錄儀 Taxi Image Alarming and Recording Metre	The Company	03222020.0	22 May 2003
一體化智能圖像採集器 All-in-one Intelligent Image Capturing Device	The Company	03222021.9	22 May 2003
出租車載客檢測器 Taxi Passenger Inspection and Detection Device	The Company	03278210.1	1 September 2003
出租車圖像報警記錄儀拍攝用 分佈式紅外照明裝置 Distributed Infrared Light Emitting Diode for Taxi Image Alarming and Recording Metre	The Company	03278383.3	8 September 2003
三自由度U型攝像機安裝法蘭盤 3 Dimensional U-shape Image Recorder Flange Plate	The Company	03278384.1	8 September 2003
闖紅燈違章照片自動篩選方法 Red Light Overshooting Law Violation Photographs Automatic Selection Method	The Company	200310106049.7	13 October 2003
記錄圖像完整的道路車輛監測裝置 Complete Image Recording Road Traffic Monitoring and Detection Equipment	The Company	200320123321.8	18 December 2003
採用補償圖像的嵌入式道路 車輛檢測記錄裝置 Embedded Supplemental Image Recording Road Traffic Inspection and Detection Equipment	The Company	200320123323.7	18 December 2003

(4) Domain Name

As at the Latest Practicable Date, the Company has registered the following domain name with the following registrar:

Domain Name	Registrant	Registration Date	Registrar	Term of licence
sampletech.cn	The Company	1 February 2004	創聯萬網國際信息技術(北京)有限公司 Civillink International Information Technology Ltd.	From 1 February 2004 to 1 February 2005

The contents contained in the above website do not form part of this prospectus.

V. SUMMARY OF THE TERMS OF THE SHARE OPTION SCHEME

The following is a summary of the principal terms of the Share Option Scheme conditionally approved by a resolution of the Shareholders dated 24 April 2004. The purpose of the Share Option Scheme is to recognise and encourage the contribution by the employees and other eligible persons to the Group and to provide incentives and help the Company to retain its existing employees and recruiting additional employees and to provide them with a direct economic interest in order to attain the long term business objectives of the Company. The adoption of the Share Option Scheme is conditional upon the satisfaction of the conditions set out in paragraph 19 below.

I. Administration

The Share Option Scheme is subject to the administration by the Board, and the decision of the Board shall be final and binding on all parties. The Board shall, subject to the GEM Listing Rules and the terms of the Share Option Scheme, have the right to determine (i) the interpretation and construction of the terms of the Share Option Scheme, (ii) the Participants (as defined in paragraph 2 below) who will be granted options under the Share Option Scheme, (iii) the number of options to be granted, the number of H shares to be subscribed and the subscription price; and (iv) any terms or conditions in relation to the grant of option.

2. Who may join

Subject to the terms and conditions of the Share Option Scheme, the Board may, at its absolute discretion, offer any full-time employees, Directors (including non-executive Directors and independent non-executive Directors) and part-time employees with weekly working hours of 10 hours and above of the Group and any advisor (professional or otherwise) or professional consultant, distributors, suppliers, agents, customers, joint venture partners, service providers which, in the opinion of the Board, has or had made contribution to the Group (the "Participants") the options to subscribe for H Shares at a price calculated in accordance with paragraph 6 below, except that the Participants who are PRC nationals or enterprises established in the PRC and have taken up any options to subscribe for H Shares shall not be entitled to exercise the options until (i) the current restrictions imposed by the relevant PRC laws and regulations restricting PRC nationals or enterprises established in the PRC from subscribing for and dealing in H Shares or any laws and regulations with similar effects (the "H Shares Restrictions") have been abolished or diminished; and (ii) the CSRC or other relevant government authorities in the PRC have approved the issue of new H Shares upon the exercise of any options which may be granted under the Share Option Scheme.

The non-PRC-national Participants, who are not subject to the H Shares Restrictions, shall be able to exercise their options in accordance with the terms of the Share Option Scheme and the GEM Listing Rules upon the implementation of the Share Option Scheme subject to the CSRC or other relevant government authorities in the PRC having approved the issue of new H Shares upon the exercise of any options which may be granted under the Share Option Scheme.

If the options are to be granted to any Participants who are connected persons or their associates, the grant is subject to the requirements of paragraph 7(v) below.

3. Grant of options

No grant of options shall be made after a price sensitive development has occurred or a price sensitive matter has been the subject of a decision until such price sensitive information has been announced pursuant to the requirements of Chapter 16 of the GEM Listing Rules. In particular, during the period commencing one month immediately preceding the earlier of: (i) the date of the board meeting (as such date is first notified to the Stock Exchange) for the approval of the company's results for any year, half-year or quarter-year period; and (ii) the deadline for the Company to publish announcement of its results for any year, half-year or quarter-year period under the GEM Listing Rules and ending on the date of the results announcement.

4. Acceptance of option offer

An offer for the grant of an option shall be made to a Participant by a letter in such form as the Board may from time to time determine and the contents of such form shall require the Participant to undertake to hold the option pursuant to the terms of the grant of the option and abide by the terms of the Share Option Scheme. The Participant who has been offered an option must accept the offer within 28 days from the date of grant, but no offer of grant can be accepted if the period of the Share Option Scheme has expired or after the Share Option Scheme has been terminated pursuant to its terms.

An option shall be deemed to have been accepted when the duplicate form of the letter of offer comprising acceptance of the option duly signed by the Participant together with the consideration of HK\$1 is received by the Company on acceptance of the option offer. Subject to all applicable requirements of the GEM Listing Rules, an option offered shall be deemed to have been granted and become effective from the date of grant of offer. In any event, the relevant remittance shall be non-refundable and shall not be regarded as part of the subscription price.

5. Terms and conditions of options

Any offer of options to Participants who are PRC nationals or enterprises established in the PRC must be made on the conditions, among others, that no options so taken up by any such Participants shall be exercisable until (i) the H Shares Restrictions have been abolished or removed; and (ii) the CSRC or other relevant government authorities in the PRC have approved the issue of new H Shares upon the exercise of any options which may be granted under the Share Option Scheme.

The non-PRC-national Participants, who are not subject to the H Share Restrictions, shall be able to exercise their options in accordance with the terms of the Share Option Scheme and the GEM Listing Rules upon the implementation of the Share Option Scheme subject to the CSRC or other relevant government authorities in the PRC having approved the issue of new H Shares upon the exercise of any options which may be granted under the Share Option Scheme.

H Shares will not be issued upon the exercise of options by any grantee (including but not limited to a grantee who is not regarded as a member of the public under the GEM Listing Rules) in the event that the Company is unable to be in full compliance with the requirements regarding public float and that all H Shares must be held by the public under Rules 25.08 and 25.09 of the GEM Listing Rules upon issuance of such H Shares.

Subject to the above, options may be granted on such terms and conditions in relation to their grant, exercise or otherwise as the Board may in its absolute discretion determine, provided such terms and conditions shall not be inconsistent with any other terms and conditions of the Share Option Scheme.

The Board shall not grant any offer of options to any Participant without first ascertaining whether such Participant is a PRC national or enterprises established in the PRC subject to the H Shares Restrictions.

6. Price of Shares

Subject to the adjustment made under paragraph II below, the subscription price for H Shares under the Share Option Scheme will be determined by the Board at its absolute discretion and notified to each grantee and will be not be less than the higher of (i) the closing price of the H Shares as stated in the Stock Exchange's daily quotations sheet on the date of grant, which must be a business day; (ii) the average closing price of the H Shares as stated in the Stock Exchange's daily quotations sheets for the five business days immediately preceding the date of the grant; and (iii) the nominal value of a H Share. For the purpose of calculating the subscription price where the Company has been listed for less than five business days, the Placing Price shall be used as the closing price for any business day falling within the period before listing.

7. Maximum number of H Shares

The total number of H Shares which may be issued upon exercise of all outstanding options granted and yet to be exercised under the Share Option Scheme or any other schemes must not in aggregate exceed 30% of H Shares of the Company in issue ("Entire Scheme Limit") from time to time subject to the following conditions:

- (i) The total number of H Shares which may be issued upon exercise of all options to be granted under the Share Option Scheme and any other schemes, must not in aggregate, exceed 10% of the number of the H Shares of the Company ("Scheme Mandate Limit") in issue as at the date of approval of the Share Option Scheme unless further shareholders' approval has been obtained pursuant to paragraphs (ii) or (iii) below. Options lapsed in accordance with the terms of the Share Option Scheme will not be counted for the purpose of calculating the 10% limit;

- (ii) Subject to the Entire Scheme Limit, the Company may seek approval by its shareholders in general meeting to renew Scheme Mandate Limit. However, the total number of H Shares which may be issued upon exercise of all options to be granted under the Share Option Scheme and other schemes of the Company under the limit as renewed must not exceed 10% of the number of H Shares of the Company in issue as at the date of the approval to renew the limit ("Renewed Scheme Mandate Limit"). Options previously granted under the schemes (including those outstanding, cancelled, lapsed in accordance with the Share Option Scheme or exercised options) will not be counted for the purpose of calculating;
- (iii) Subject to the Entire Scheme Limit, the Company may seek separate approval by its shareholders in general meeting to grant options beyond Scheme Mandate Limit provided the options in excess of the Scheme Mandate Limit are granted only to Participants specifically identified by the Company before such approval is sought;
- (iv) No Participants shall be granted an option which, if all the options granted to a Participant (including exercised, cancelled and outstanding options) in any 12-month period up to the date of the grant are exercised in full, would result in such person's maximum entitlement exceeding 1% of the number of H Shares of the Company in issue, unless approved by shareholders in general meeting, with such Participant and his associates abstaining from voting; and
- (v) Each grant of options to a connected person (as defined in the GEM Listing Rules) must be approved by the independent non-executive Directors (excluding independent non-executive Director who is the grantee of the options). Where any grant of options to a substantial shareholder (as defined in the GEM Listing Rules) or an independent non-executive director, or any of their respective associates, would result in the H Shares issued and to be issued upon exercise of all options granted and to be granted (including options exercised, cancelled and outstanding) to such person in the 12-month period up to and including the date of such grant, representing in aggregate over 0.1% of the H Shares in issue and having an aggregate value, based on the closing price of H Shares at the date of each grant, in excess of HK\$5 million, such further grant of options must be approved by the independent shareholders of the Company. All connected persons of the Company and their associates must abstain from voting in favour of the resolution in the general meeting of the Company.

8. Time of exercise of option

No Participants who are PRC nationals or enterprises established in the PRC and have taken up any options to subscribe for H Shares shall be entitled to exercise any such options until (i) the H Shares Restrictions have been abolished or removed; and (ii) approvals have been obtained from the CSRC or other relevant government authorities in the PRC for the exercise of any options which may be granted under the Share Option Scheme. Subject to the above, an option may be exercised in accordance with the terms of the Share Option Scheme at any time during a period (the "Option Period") to be notified by the Board to each grantee provided that the period within which the option must be exercised from the date of grant of the option to not more than ten years from the date of grant of the option.

9. Rights are personal to grantee

An option is personal to the grantee. No grantee shall, or agree to, sell, transfer, assign, charge, mortgage and encumber any option or create any third party interest over or in relation to any option. The Company is entitled to cancel options granted to a grantee but not exercised if the grantee contravenes any provisions in this paragraph.

10. Rights on ceasing employment, death, takeover, compromise, voluntary winding up, compromise for reconstruction or amalgamation and reorganisation

Subject to the following and the H Shares Restrictions having been abolished or removed and approvals have been obtained from the CSRC and any other relevant government authorities in the PRC for the exercise of any options which may be granted under the Share Option Scheme to PRC nationals or enterprises established in the PRC, an option may be exercised by the grantee (or his or her personal representative) after the occurrence of the events as follows:

(i) *Rights on ceasing employment*

If the grantee of an option ceases to be an employee of any member of the Group for any reason (other than death and one or more of the grounds for termination of his or her employment set out in paragraph 12(i)(c)), the grantee may exercise the option up to the grantee's entitlement at the date of cessation (to the extent not already exercised) within the period of three months following the date of such cessation which date shall be the last actual working day with the Company or the relevant subsidiary whether salary is paid in lieu of notice or not.

(ii) *Rights on death*

If the grantee of an option dies before exercising the option in full and none of the events which would be a ground for termination of his or her employment set out in paragraph 12(i)(c) arises, the personal representative(s) of the grantee shall be entitled within a period of twelve months from the date of death to exercise the option up to the entitlement of the grantee as at the date of death (to the extent not already exercised).

(iii) *Rights on takeover*

If a general offer by way of takeover (otherwise than by a scheme of arrangement) is made in the PRC and/or Hong Kong to all the holders of H Shares (or all such holders other than the offeror, any persons under the control of the offeror or parties in concert with the offeror) and, in the case of general offer in the PRC, such general offer obligation is not exempted by the CSRC and in the case of a general offer in Hong Kong, such offer becomes or is declared unconditional prior to the expiry date of the relevant option, the grantee (or his or her personal representatives) shall be entitled to exercise the option in full (to the extent not already exercised) at any time within one month after the date on which the offer becomes or is declared unconditional.

(iv) *Rights on a compromise or arrangement*

If a general offer by way of a compromise or arrangement is made to all the holders of H Shares and the scheme has been approved by the necessary number of holders of Shares at the requisite meetings, the grantee (or his or her personal representatives) may thereafter (but before such time as shall be notified by the Company) by notice in writing to the Company exercise the option in full (to the extent not already exercised).

(v) *Rights on voluntary winding-up*

In the event a notice is given by the Company to its members to convene a general meeting for the purposes of considering, and if thought fit, approving a resolution to voluntarily wind up the Company, the Company shall forthwith give notice thereof to all grantees and thereupon, the grantee (or his or her personal representatives) may by notice in writing to the Company (such notice to be received by the Company not later than four business days prior to the proposed general meeting), exercise the option in full (to the extent not already exercised). The Company shall as soon as possible and, in any event, no later than the business day immediately prior to the date of the proposed general meeting referred to above, allot the relevant H Shares to the grantee credited as fully paid.

(vi) *Rights on reconstruction or amalgamation*

If, pursuant to the relevant laws and regulations applicable to the Company, a compromise or arrangement between the Company and its members or creditors is proposed in connection with a scheme for the reconstruction of the Company or its amalgamation with any other company or companies, the Company shall give notice thereof to all grantees on the same day as it dispatches to each member or creditor of the Company a notice summoning the meeting to consider such a compromise or arrangement, and thereupon each grantee (or his or her personal representatives) shall by notice in writing to the Company accompanied by the remittance for the exercise price in respect of the relevant options exercise all or any of his options in whole or in part prior to 2 days immediately preceding the date of the meeting directed to be convened by the court for the purposes of considering such compromise or arrangement. The Company shall as soon as possible and in any event no later than the business day immediately prior to the date of the proposed meeting, allot and issue the relevant H Shares to the grantee credited as fully paid and registered as the holder thereof. With effect from the date of such meeting, the rights of all grantees to exercise their respective options shall forthwith be suspended. Upon such compromise or arrangement becoming effective, all options shall, to the extent that they have not been exercised, lapse and determine. The Directors shall endeavour to procure that the H Shares issued as a result of the exercise of options under the provisions of the Share Option Scheme shall for the purposes of such compromise or arrangement form part of the issued share capital of the Company on the effective date thereof and that such H Shares shall in all respects be subject to such compromise or arrangement. If for any reason such compromise or arrangement is not approved by the court (whether upon the terms presented to the court or upon any other terms as may be approved by such court) the rights of grantees to exercise their respective options shall with effect from the date of the order of the court be restored in full and shall thereupon become exercisable (but subject to the other terms of the Share Option Scheme)

as if such compromise or arrangement had not been proposed by the Company and no claim shall lie against the Company or any of its officers for any loss or damage sustained by any grantee as a result of the aforesaid suspension.

11. Effects of alterations to capital

In the event of any alteration in the capital structure of the Company whilst any option remains exercisable or the Share Option Scheme remains in effect, and such event arises from a capitalization of profits or reserves, rights issue, consolidation, subdivision or reduction of the share capital of the Company or otherwise, such corresponding alterations (if any) certified by the auditors for the time being of or an independent financial adviser to the Company as fair and reasonable will be made to the number or nominal amount of H Shares referred to in the Paragraph 7 above provided that (i) any such adjustment shall be made on the basis that the aggregate subscription price payable by a grantee on the full exercise of any option shall remain as nearly as possible the same (but shall not be greater than) as it was before the event; (ii) no such adjustment shall be made the effect of which would render a H Share be issued at less than its nominal value; (iii) no such adjustment shall be made the effect of which would be to increase the proportion of the issued share capital of the Company for which any grantee would have been entitled to subscribe had he exercised all the options held by him immediately prior to such adjustment; and (iv) the issue of securities of the Company as consideration in a transaction shall not be regarded as a circumstance requiring any such adjustment. In addition, in respect of any such adjustments, other than any adjustments made on a capitalization issue, such auditors or independent financial adviser must confirm to the Directors in writing that the adjustments satisfy the requirements of the relevant provision of the GEM Listing Rules.

12. Lapse of option

- (i) Subject to paragraph 12(ii) below, an option shall lapse automatically and not be exercisable (to the extent not already exercised) on the earliest of:
 - (a) the expiry of the Option Period;
 - (b) the expiry of the periods referred to in paragraph 10;
 - (c) the date on which the grantee ceases to be an employee by reason of the termination of his or her employment on grounds that he or she has been guilty of serious misconduct, or appears either to be unable to pay or to have no reasonable prospect of being able to pay his or her debts or has become insolvent or has made any arrangement or composition with his or her creditors generally, or has been convicted of any criminal offence involving integrity or honesty;
 - (d) the date of the commencement of the winding up of the Company; and
 - (e) the date on which the grantee commits a breach of paragraph 9.

- (ii) The transfer of position of a Participant from a member of the Group to another member of the Group shall not be regarded as cessation of employment. In the event that the grantee is on leave and the relevant member of the Group is in the opinion that such leave will not jeopardise the employment, the employment will not be regarded as having been ceased.
- (iii) The Board shall notify the grantee by notice in writing when his/her options lapse. The grantee shall, upon the receipt of such notice, return the certificate(s) of the options to the Company.

13. Ranking of H Shares

The H Shares, which is a separate class from Domestic Shares, to be allotted upon the exercise of an option will be subject to the Articles of Association for the time being in force and will rank *pari passu* with the fully paid H Shares in issue on the date of exercise of the option and in particular will rank in full for all dividends or other distributions declared, made or paid on or after the date of exercise of the option other than any dividend or other distribution previously declared or recommended or resolved to be paid or made if the record date therefor is before the date of exercise of the option.

Unless the context otherwise requires, references to “H Shares” in the Share Option Scheme include references to shares in the Company of any such nominal amount as shall result from a subdivision, consolidation, reclassification or reconstruction of the share capital of the Company from time to time.

14. Cancellation of options granted

Any cancellation of options granted but not exercised must be agreed by the grantee and approved by shareholders of the Company in general meeting, with grantees and their associates abstaining from voting. Any vote taken at the meeting to approve such cancellation must be taken by poll. Cancelled options may be re-issued after such cancellation has been approved, provided that re-issued options shall only be granted in compliance with the terms of the Share Option Scheme.

If the Company cancels the options previously granted to a grantee, new options can only be reissued to that grantee provided that the new options to be issued is within the maximum number of unissued options (excluding cancelled options) approved by the Shareholders.

15. Minimum Period for Holding an Option and Performance Target

Any Participant who has been granted an option is not required to hold the option for a minimum period or achieve any performance target before the option is exercised.

16. Period of Share Option Scheme

The Share Option Scheme will remain valid for a period of 10 years commencing on the date on which the Share Option scheme became unconditional (save that the Company may by ordinary resolution in general meeting or the Board, at any time terminate the operation of the Share Option Scheme). Upon termination, no further options will be granted but the provisions of the Share Option Scheme shall in all other respects remain in full force and effect and options which are granted during the life of the Share Option Scheme (but not yet exercised) may continue to be exercisable in accordance with their terms of issue.

17. Alteration to Share Option Scheme

The Share Option Scheme may be altered in any respect by resolution of the Board except that certain provisions of the Share Option Scheme in relation to, inter alia, the matters contained in rule 23.03 of the GEM Listing Rules shall not be altered to the advantage of the grantees or the prospective grantees except with the prior sanction of a resolution of the Company in general meeting provided that no such alteration shall adversely affect the terms of issue of any option granted but not exercised or agreed to be granted prior to such alteration except with the consent or sanction of such majority of the grantees as would be required of the holders of the H Shares under the Articles of Association for the time being of the Company for a variation of the rights attached to the H Share and provided further that any alterations to the terms and conditions of the Share Option Scheme which are of a material nature or any change to the terms of options granted must be approved by the Shareholders of the Company in general meeting except where the alterations take effect automatically under the existing provisions of the Share Option Scheme.

18. Termination of the Share Option Scheme

The Company may, at any time, terminate the operation of the Share Option Scheme by an ordinary resolution in the general meeting. In this circumstance, the Company must not grant any options. However, in respect of those options which have been granted (but not yet exercised), the Share Option Scheme will remain in full force and effect in all other aspects. The options granted (but not yet exercised) before termination of the Share Option Scheme will continue to be valid and can be exercised under the Share Option Scheme.

19. Conditions of the Share Option Scheme

The Share Option Scheme is conditional on (a) the passing of resolution(s) by the Shareholders to approve and adopt the Share Option Scheme (with grantees and their respective associates abstaining from voting) and to authorise the Directors to grant options to subscribe for H Shares and to allot, issue and deal with the H Shares pursuant to the exercise of any options granted under the Share Option Scheme; (b) the GEM Listing Committee granting the listing of, and permission to deal in, any H Shares which may be issued pursuant to the exercise of options granted under the Share Option Scheme; and (c) the obligation of the Placing Underwriters under the Placing and Underwriting Agreement becoming unconditional (including, if relevant, as a result of the waiver of any such condition(s)) and not being terminated in accordance with the terms of that agreement or otherwise.

Application has been made to the GEM Listing Committee for the listing of, and permission to deal in, the H Shares which may be issued pursuant to the exercise of the options granted under the Share Option Scheme.

As at the date of this prospectus, no option has been granted or agreed to be granted under the Share Option Scheme.

20. Conflicts with GEM Listing Rules

Where there are any conflicts between the GEM Listing Rules and the terms of the Share Option Scheme, the GEM Listing Rules shall prevail.

VI. OTHER INFORMATION

1. Estate duty and other tax indemnity

Under the Deed of Indemnity referred to in item 4 of the sub-section headed "Summary of material contracts" under the section headed "Further information about the business" of this appendix, each of Sample Group, Nanjing Zhongbei, Huadong Technology, Sample Commerce City and Sha Min (沙敏) has given indemnities in favour of the Company in relation to taxation and any other liabilities which might fall upon the Company in respect of any income, profits or gains earned, accrued or received on or before the date of this prospectus.

The Directors have been advised that no material liability for estate duty is likely to fall on the Company under PRC law.

2. Litigation

As at the Latest Practicable Date, the Company was not engaged in any litigation or arbitration of material importance and so far as the Directors are aware, no litigation, arbitration or claim of material importance was pending or threatened against the Company.

3. Sponsor, bookrunner and lead manager

Core Pacific – Yamaichi Capital Limited has made an application on behalf of the Company to the GEM Listing Committee for the listing of, and permission to deal in, any of the H Shares to be issued and/or sold under the Placing (including the H Shares which may be issued upon the exercise of any options which may be granted under the Share Option Scheme). All necessary arrangements have been made to enable the H Shares to be admitted into CCASS.

Core Pacific – Yamaichi Capital Limited is the Sponsor and Core Pacific – Yamaichi International (H.K.) Limited is the Lead Manager in relation to the Placing.

Pursuant to the GEM Listing Rules, Core Pacific – Yamaichi Capital Limited has agreed to provide advisory service to the Company for a period covering the remainder of the financial year ending 31 December 2004 and the two financial years thereafter; and the Company has agreed to pay an annual fee in connection with such service.

4. Preliminary expenses

The preliminary expenses of the Company were approximately RMB1,009,000 (approximately HK\$952,000) and were paid by the Company.

5. Promoters

The Promoters are Sample Group, Nanjing Zhongbei, Huadong Technology, Sample Commerce City, Nanjing Daily and Sha Min (沙敏). For further details of the Promoters, please refer to the section headed “General overview of the group” in this prospectus. Save as disclosed in this prospectus, within the two years preceding the date of this prospectus, no cash amount or security or other benefit has been paid, allotted or given or proposed to be paid, allotted or given to the Promoters in connection with the Placing or the related transactions described in this prospectus.

6. Binding effect

This prospectus shall have the effect, if an application is made in pursuance hereof, of rendering all persons concerned bound by all of the provisions (other than the penal provisions) of sections 44A and 44B of the Companies Ordinance insofar as applicable.

7. No material adverse change and interruption of business

Save as disclosed in this prospectus and to the best knowledge of the Directors, there has been no adverse change in the financial position, state of affairs or future prospects of the Company since 31 December 2003 (being the date of the most recently published audited financial statements of the Company).

Save as disclosed herein, there has not been any interruption in the business of the Company which has had or may have a material adverse effect on the financial position of the Company in 24 months preceding the date of this prospectus.

8. Taxation of holders of the H Shares

Dealing in the H Shares is subject to Hong Kong stamp duty.

9. Qualifications of the experts

Name	Qualification
Core Pacific – Yamaichi Capital Limited	Deemed licenced corporation for types 1, 4, 6, 9 regulated activities under the SFO
Vigers Appraisal & Consulting Limited	Professional surveyors and independent valuer
Commerce & Finance Law Office	Qualified PRC lawyers
Deloitte Touche Tohmatsu	Certified public accountants

10. Consents of experts

Each of Core Pacific – Yamaichi Capital Limited, Vigers Appraisal & Consulting Limited, Commerce & Finance Law Office and Deloitte Touche Tohmatsu has given and has not withdrawn its respective written consent to the issue of this prospectus with the inclusion of its report and/or letter and/or advice and/or valuation certificate and/or the references to its name in the form and context in which they are respectively included or appeared.

11. Particulars of the Vendor

The National Council for Social Security Fund, PRC (全國社會保障基金理事會) is set up by the State Council. Its principal function includes asset management of the social security fund of the PRC. Its registered address is at No. A2, Yue Tan Bei Street, Xi Cheng District, Beijing, the PRC.

The 900,000 Domestic Shares held by the Vendor will be converted into 900,000 H Shares and will be offered for sale under the Placing.

12. Miscellaneous

Save as disclosed in this prospectus:

- (1) within the two years preceding the date of this prospectus, no share or loan capital of the Company has been issued or agreed to be issued, as fully or partly paid, either for cash or for a consideration other than cash;
- (2) no share or loan capital of the Company is under any option or is agreed conditionally or unconditionally to be put under option;
- (3) within the two years preceding the date of this prospectus, no commissions, discounts, brokerages or other special terms (if any) have been granted in connection with the issue or sale of any share or loan capital of the Company;
- (4) the Company has no founders or management or deferred shares;
- (5) none of the equity and debt securities of the Company is listed or dealt in any other stock exchange nor is any listing or permission to deal being or proposed to be sought;
- (6) the Company does not have any outstanding convertible debt securities;
- (7) within the two years preceding the date of this prospectus, no commissions (except the commissions to sub-underwriters) have been paid or are payable for subscribing or agreeing to subscribe, or procuring, or agreeing to procure subscription for any shares or debentures in the Company; and
- (8) none of the experts whose names appear in the paragraph headed "Consents of experts" in this appendix is interested in any shares in the Company, nor has any right or option (whether legally enforceable or not) to subscribe for or to nominate persons to subscribe for any securities in the Company.

DOCUMENTS DELIVERED TO THE REGISTRAR OF COMPANIES

The documents attached to a copy of this prospectus and registered by the Registrar of Companies in Hong Kong were copies of the written consents referred to in the paragraph headed "Consents of experts" in Appendix VII to this prospectus, copies of the material contracts referred to in the paragraph headed "Summary of material contracts" in Appendix VII to this prospectus and a statement of the particulars of the Vendor.

DOCUMENTS AVAILABLE FOR INSPECTION

Copies of the following documents will be available for inspection at the offices of Kwok & Yih at 37th Floor, Gloucester Tower, The Landmark, Central, Hong Kong from 4:00 p.m. to 5:00 p.m. on the date of this prospectus and during normal business hours from 9:00 a.m. to 5:00 p.m. up to and including 16 June 2004:

- (a) the Articles of Association;
- (b) the accountants' report prepared by Deloitte Touche Tohmatsu, the text of which is set out in Appendix I to this prospectus;
- (c) the comfort letter on the pro forma statement of adjusted net tangible assets of the Group prepared by Deloitte Touche Tohmatsu, the text of which is set out in Appendix II to this prospectus;
- (d) the letter, summary of values and the valuation certificates relating to the property interests of the Group prepared by Vigers Appraisal & Consulting Limited, the text of which is set out in Appendix III to this prospectus;
- (e) the PRC legal opinion dated 2 June 2004 prepared by Commerce & Finance Law Office, the PRC legal advisers to the Company;
- (f) such audited financial statements as have been prepared for the companies comprising the Group for each of the three years ended 31 December 2003 or from their respective dates of establishment where this is a shorter period;
- (g) the material contracts referred to in the paragraph headed "Summary of material contracts" in Appendix VII to this prospectus;
- (h) the service contracts referred to in the paragraph headed "Particulars of service contracts and remuneration of Directors and Supervisors" in Appendix VII to this prospectus;
- (i) the written consents referred to in the paragraph headed "Consents of experts" in Appendix VII to this prospectus;
- (j) a statement of the particulars of the Vendor;
- (k) the Company Law together with an unofficial English translation thereof;

- (l) the Mandatory Provisions together with an unofficial English translation thereof; and
- (m) the Special Regulations together with an unofficial English translation thereof.