

A large circular graphic with a white, stylized 'C' shape cutout. The background inside the circle is a grayscale, motion-blurred image of a road or tunnel, suggesting speed and technology. A red horizontal bar is positioned below the year "2022".

**2022**

ANNUAL REPORT

**NEXTEER AUTOMOTIVE GROUP LIMITED**

耐世特汽車系統集團有限公司

**STOCK CODE: 1316**

Incorporated under the laws of the Cayman Islands with limited liability

***A LEADER IN INTUITIVE MOTION CONTROL***

# OUR STRATEGY FOR PROFITABLE GROWTH



Expand & Diversify  
Revenue Base



Strengthen  
Technology Leadership



Capitalise on EPS  
as Enabler for ADAS



Optimise  
Cost Structure



Pursue Select  
Acquisitions & Alliances



Target China &  
Emerging Markets

# Contents

Corporate Profile .....	2
Corporate Information .....	4
2022 Highlights .....	5
CEO Statement .....	6
Our Products & Technologies .....	8
Business Overview .....	13
Financial Highlights .....	27
Management Discussion and Analysis .....	28
Directors and Senior Management .....	40
Directors' Report .....	48
Corporate Governance Report .....	66
Independent Auditor's Report .....	82
Consolidated Balance Sheet .....	86
Consolidated Income Statement .....	88
Consolidated Statement of Comprehensive Income .....	89
Consolidated Statement of Changes in Equity .....	90
Consolidated Statement of Cash Flows .....	91
Notes to the Consolidated Financial Statements .....	92
Five Years' Financial Summary .....	162

## Corporate Profile

Nexteer Automotive Group Limited (the **Company**) together with its subsidiaries are collectively referred to as **we, us, our, Nexteer, Nexteer Automotive** or the **Group**. Nexteer Automotive's vision is to be the global leading motion control technology company accelerating mobility to be safe, green and exciting.

*“ We are the Leading  
**MOTION CONTROL  
TECHNOLOGY COMPANY**  
that Accelerates Mobility to be  
**SAFE, GREEN & EXCITING.”***

OUR VISION

Our innovative product and technology portfolio of advanced steering and driveline systems solves motion control challenges across all megatrends – including electrification, software/connectivity, advanced driver assistance systems (**ADAS**)/automated driving (**AD**) and shared mobility.

In-house development and full system integration of hardware, software and electronics provides Nexteer a competitive advantage as an agile, full-service supplier to automotive original equipment manufacturers (**OEM**) around the world.

Our ability to seamlessly integrate our systems into OEM vehicles is a testament to our more than 110-year heritage of vehicle integration expertise and product craftsmanship. Our “One Nexteer” culture inspires employees to achieve personal and corporate growth by focusing on our core values across all aspects of the Company: people first, operational excellence and enterprise growth. As One Nexteer, our vision guides us every day, and we're making it a reality by challenging the impossible and making tomorrow better than today.

We strive to be the partner of choice for our customers and suppliers by delivering highly engineered, safety-critical products and building enduring relationships.

Nexteer provides real-world, vehicle-level solutions by being:

- **Customer Focused:** Respected and trusted for delivering on commitments
- **Proactive:** We listen carefully to understand customer needs, requirements and aspirations
- **Innovative:** A market leader in steering and driveline system innovation and value-added service
- **Agile:** Able to respond quickly with high-quality, cost-effective solutions
- **Global:** Committed to exceeding customer and vehicle needs every time, in every customer-targeted market

## GLOBAL FOOTPRINT & CUSTOMERS

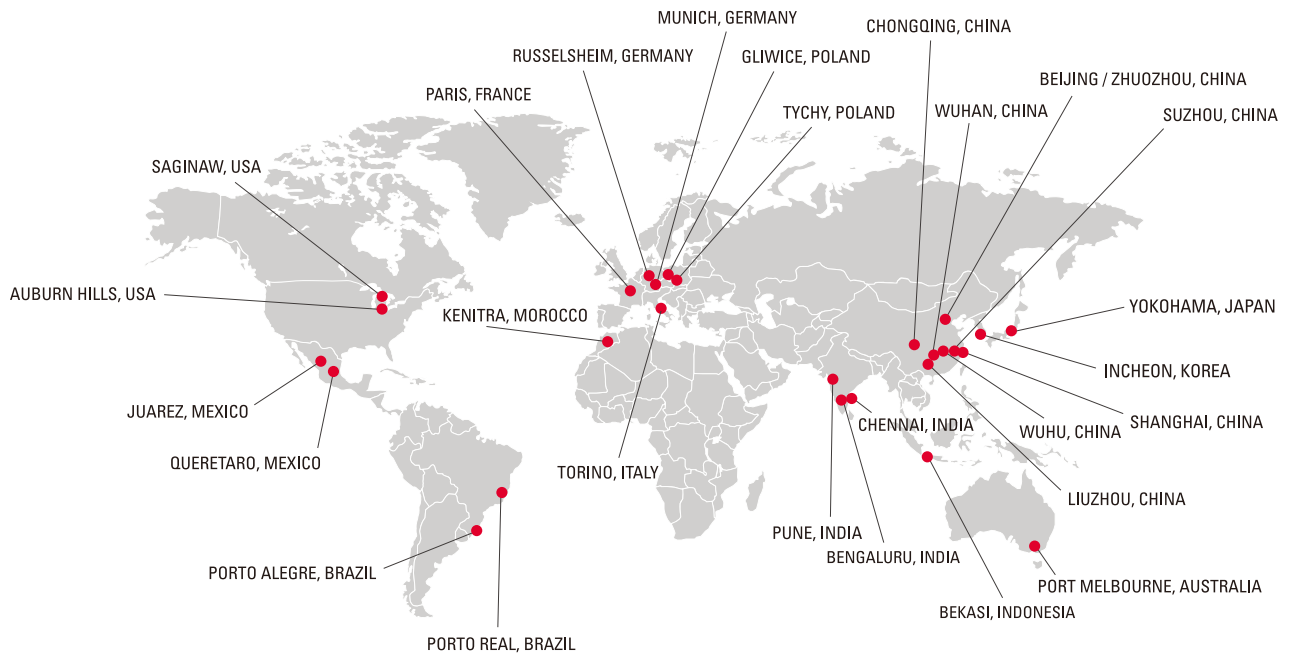

- **World Headquarters:** Auburn Hills, Michigan, United States of America (**USA** or **US**)
- **Manufacturing Plants:** 26, including 2 non-consolidated joint ventures (**JV**)
- **Technical & Software Centres:** 4
- **Customer Service Centres:** 13
- **Products:** Electric Power Steering and Steer-by-Wire (**EPS** and **SbW**), Steering Columns and Intermediate Shafts (**CIS**), Driveline Systems (**DL**), Hydraulic Power Steering (**HPS**), eDrive, Software Solutions
- **Global Customers:** 60+, including BMW Group (**BMW**) BYD Auto Co., Ltd. (**BYD**), Changan Automobile Co., Ltd. (**Changan**), Dongfeng Peugeot Citroën Automobile Co., Ltd. (**DPCA**), Ford Motor Company (**Ford**), General Motors Company and Subsidiaries (**GM**), Great Wall Motor Company Limited (**GWM**), Maruti Suzuki India Limited (**Maruti-Suzuki**), Renault-Nissan-Mitsubishi Alliance (**RNM**), SAIC General Motors Co., Ltd., SAIC-GM-Wuling Automobile Co., Ltd. (**SGMW**), Stellantis N.V. (**Stellantis**), Toyota Motor Corporation (**Toyota**) and Volkswagen Group (**VW**) as well as domestic automakers in China, India and South America

# Corporate Information

## BOARD OF DIRECTORS

### Executive Directors

LEI, Zili (雷自力)  
*(Chairman and Chief Executive Officer)*  
 MILAVEC, Robin Zane

### Non-Executive Directors

WANG, Jian (王堅)  
 ZHANG, Wendong (張文冬)  
 SHI, Shiming (石仕明)

### Independent Non-Executive Directors

LIU, Jianjun (劉健君)  
 WANG, Bin (王斌)  
 YUE, Yun (岳雲)

## COMPANY SECRETARY

CHU, Cheuk Ting (朱卓婷)

## AUTHORISED REPRESENTATIVES

LEI, Zili (雷自力)  
 CHU, Cheuk Ting (朱卓婷)

## LEGAL ADVISERS

**As to Hong Kong Law**  
 DLA Piper Hong Kong

**As to Cayman Islands Law**  
 Maples and Calder

## AUDITOR

Deloitte Touche Tohmatsu  
 Certified Public Accountants and Registered PIE Auditors

## AUDIT AND COMPLIANCE COMMITTEE

WANG, Bin (王斌) *(Chairman)*  
 SHI, Shiming (石仕明)  
 YUE, Yun (岳雲)

## REMUNERATION AND NOMINATION COMMITTEE

LIU, Jianjun (劉健君) *(Chairman)*  
 ZHANG, Wendong (張文冬)  
 WANG, Bin (王斌)

## HEADQUARTERS

1272 Doris Road  
 Auburn Hills, Michigan 48326, USA

## REGISTERED OFFICE

P.O. Box 309, Ugland House  
 Grand Cayman, KY1-1104  
 Cayman Islands

## PRINCIPAL PLACE OF BUSINESS IN HONG KONG

31/F, Tower Two  
 Times Square  
 1 Matheson Street  
 Causeway Bay  
 Hong Kong

## PRINCIPAL SHARE REGISTRAR AND TRANSFER OFFICE

Maples Fund Services (Cayman) Limited  
 P.O. Box 1093, Boundary Hall  
 Cricket Square  
 Grand Cayman, KY1-1102  
 Cayman Islands

## HONG KONG BRANCH SHARE REGISTRAR AND TRANSFER OFFICE

Computershare Hong Kong Investor Services Limited  
 Shops 1712-1716  
 17th Floor, Hopewell Centre  
 183 Queen's Road East  
 Wanchai  
 Hong Kong

## PRINCIPAL BANKERS

Bank of America  
 Bank of China  
 Bank Pekao SA  
 China CITIC Bank  
 China Construction Bank  
 Comerica Bank  
 JPMorgan Chase & Co.  
 PKO Bank Polski SA  
 Shanghai Pudong Development Bank  
 Wells Fargo Capital Finance

## STOCK CODE

Share Listing  
 Ordinary Shares  
 The Stock Exchange of Hong Kong Limited  
 (the **Hong Kong Stock Exchange**)  
 (Stock code: 1316)

## COMPANY WEBSITE

<http://www.nextteer.com/>

# 2022 HIGHLIGHTS

US\$ **3.8B**  
REVENUE

**42** PROGRAMME  
LAUNCHES

 **16 on EVs**

US\$ **6.4B**  
BOOKINGS

 **73% NEW CONQUEST**

 **83% EVs\***



**~12,600**  
Employees



**60+**  
CUSTOMERS  
GLOBALLY

\* EV is defined as Battery Electric Vehicles, Full Hybrid Electric Vehicles and Plug-In Hybrid Electric Vehicles

## CEO Statement



**“Over the past few years, Nexteer has continued to outperform the market in revenue growth as we launch new programmes driven by our strong bookings of new and conquest business... We remain optimistic that the operating environment will improve as we move forward and that our strategy for profitable growth will enable us to maintain business growth above market levels.”**

**LEI, Zili**

**Chairman and Chief Executive Officer**

### Dear Shareholders:

On behalf of Nexteer, I am honoured to share with you our 2022 Annual Report and provide an overview of Nexteer’s current business, strategy for future profitable growth and highlight a few of the year’s successes in driving shareholder value.

### MANAGED THE CHALLENGING, NEAR-TERM ENVIRONMENT & POSITIONED NEXTEER FOR FUTURE PROFITABLE GROWTH

In 2022, the automotive industry continued to experience significant disruptions driven by ongoing COVID issues, inflationary pressures and global supply chain constraints, as well as new challenges such as the impacts from the Ukraine Russia War and increasing energy prices.

Inflationary pressures and semiconductor shortages, among others, proved to be headwinds to our 2022 financial results. We continue to take swift actions to increase profit margins including:

- Increase revenue conversion to profit
- Share inflationary costs with customers
- Collaboratively manage supplier costs
- Reduce cost through design and manufacturing efficiency

- Lower upfront costs for engineering and capital
- Focus on quality

The lessons learned from the past few challenging years and the confidence bolstered from our successes will serve us well as we continue to face ongoing challenges such as continued inflationary impacts and potential further economic slowdown.

Over the past few years, Nexteer has continued to outperform the market in revenue growth as we launch new programmes driven by our strong bookings of new and conquest business. So, while the environment remains challenging, our Company remains well-positioned for success as we continue to execute on our strategy to achieve profitable growth, above market levels.

### CONTINUED GROWTH PATH: 2022 HIGHLIGHTS

While 2022 presented various challenges, the year also brought about many opportunities. I’m proud of our team’s accomplishments and how we are positioning the Company to seize the many opportunities ahead of us.

Here are a few examples of the significant accomplishments our team achieved during 2022:

- Achieved customer programme bookings totaling US\$6.389 billion



## CEO Statement

- Successfully launched 42 new customer programmes across all regions – marking another period of strong programme launches
- Delivered industry-leading supply performance to our customers, despite the chip shortage and other supply chain disruptions
- Developed and implemented creative solutions to supply chain issues, especially chip substitutions/alternatives in record time
- Continued commitment to technology leadership and megatrend alignment for future growth – including electrification and software megatrends
- Honoured for innovation, quality, excellence and exceptional customer relationships – including prestigious *Automotive News* PACE and PACEpilot Award Finalists & Consumer Electronics Show (CES) Innovation Award Honoree

## ANOTHER STRONG YEAR OF BOOKINGS & BREAKTHROUGHS

One of our 2022 highlights that I'd like to call special attention to is our 2022 Bookings total of US\$6.389 billion. 2022 marked another strong booking period driven by the high demand of our innovative motion control technologies.

Our megatrend alignment plus our customer, product and market diversification positions us well moving forward. For example in the first half of 2022, the Company earned a significant booking of the industry's first high volume production of SbW business with a leading global OEM. It will be a milestone moment to unlock the value of this future steering technology as the lifetime revenue of this booking contract is one of the largest in our Company's history.

In addition to the breakthrough SbW win, our leadership position in the North America (NA) truck/sport utility vehicle (SUV) market strengthened further in 2022 by securing three brand-new battery electric vehicle (BEV) truck platforms and one new SUV platform from NA customers. These bookings highlight how well Nexteer is positioned in the convergence of electrification and the truck market.

Another proof point of our technology alignment with the electrification megatrend is the book of business we are building with local Chinese OEMs that are growing, especially with electric vehicles (EVs). To date, we have successfully secured REPS programmes with nine Chinese customers which have or will launch in the next two years, including traditional and NEV customers. In 2022, we also secured our first DL win with a leading global EV OEM – adding to the CIS business we won with this OEM last year.

## REVIEW OF RESULTS

For the year ended December 31, 2022, the Company's revenue was US\$3,839.7 million which represents a 14.3% increase when compared with 2021. Adjusting for foreign currency and commodity recoveries from our customers, Nexteer's revenue increased by 16.1%, outperforming the increase in global OEM vehicle production of 6.2%, by 990 basis points. Operating profit was US\$86.3 million and net profit attributable to equity holders of the Company was US\$58.0 million. Nexteer's revenue growth for the full year 2022 continued to outpace the market as measured by the change in global OEM unit production, a result of our continued focus on expanding our regional and product line positions with current customers and securing conquest business with new customers. While revenue growth remained strong, inflationary and supply chain pressures reduced the Group's profit when compared to 2021.

## APPRECIATION

While 2022 was another challenging year, the efforts of our global One Nexteer team have improved our Company's resiliency and robustness and are positioning us to realise our vision as the leading motion control technology company accelerating mobility to be safe, green and exciting. We remain optimistic that the operating environment will improve as we move forward and that our strategy for profitable growth will enable us to maintain business growth above market levels.

We appreciate the support of our shareholders and the efforts of our One Nexteer team that have prepared us to take advantage of the exciting opportunities our future holds.

**LEI, Zili**

*Chairman and Chief Executive Officer*

## OUR PRODUCTS & TECHNOLOGIES



We design, develop, manufacture and distribute steering and driveline systems and components, primarily for automotive OEMs.

A steering system provides lateral directional control of the vehicle. Our steering system products include EPS, SbW and HPS, as well as CIS.

A DL system transfers power from the gearbox to the driven wheels. Our DL products include frontwheel drive halfshafts, intermediate drive shafts and rear-wheel drive halfshafts, as well as propeller shaft constant velocity joints.

We also collaborate with OEMs on software feature development, execution and vehicle integration. Our advanced steering software solutions support OEMs' needs in the increasing shift to "software-defined" vehicles.

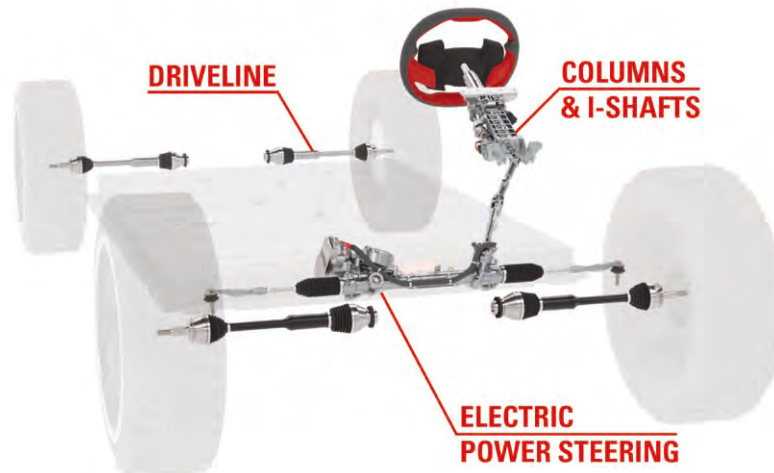

## Our Products &amp; Technologies

## ELECTRIC POWER STEERING & STEER-BY-WIRE

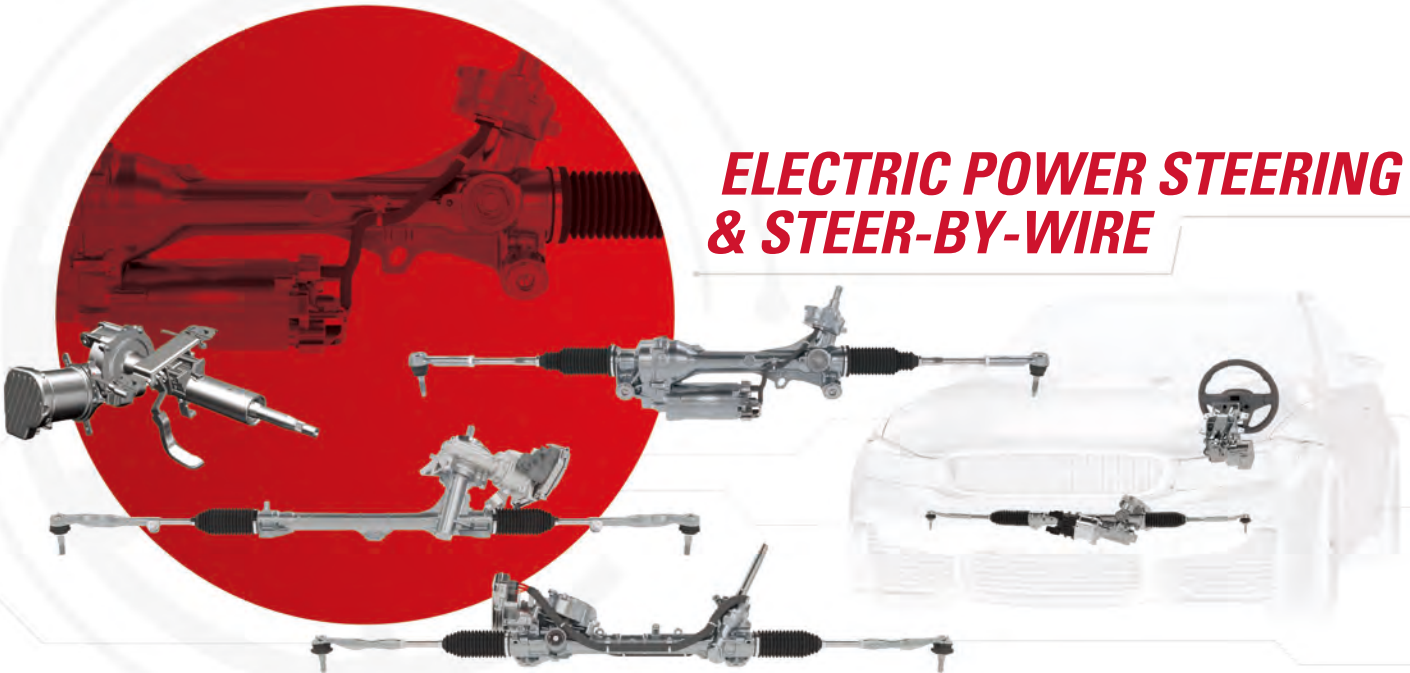

EPS uses an electric motor to assist driver steering. Hardware and software are developed concurrently and work seamlessly together to connect the driver with the road – accounting for driving dynamics and the operating environment. This “connection to the road” provides the driver an experience consistent with the vehicle’s brand (such as luxury, sport, etc.), while also giving important safety cues regarding the type of road surface the driver is traveling on (such as icy, gravel, etc.).

EPS is a key ADAS feature enabler. EPS translates data from the vehicle’s electronic control unit (ECU) into precise mechanical steering functions. Many Nexteer EPS-enabled ADAS features are already on the road today such as park assist, lane keeping, lane departure warning, traffic jam assist and more.

SbW replaces the mechanical steering connection between the hand wheel and road wheels with algorithms, electronics and actuators. SbW emulates the “feel of the road,” offers a wide performance range (including sporty, luxury, comfort, etc.) and enhances maneuverability through our dynamic variable steering ratio. SbW enables advanced safety and performance features and functionality, as well as opens new possibilities for vehicle light-weighting and packaging flexibility.

Our full portfolio of steering technologies meets global OEM needs for everything from small cars to heavy-duty trucks and light commercial vehicles – including internal combustion engine (ICE), hybrid and electric vehicles (EVs).

### Nexteer’s EPS & SbW Portfolio:

- Rack-Assist EPS (REPS)
- Dual Pinion-Assist EPS (DPEPS)
- Single Pinion-Assist EPS (SPEPS)
- Column-Assist EPS (CEPS)
- Brush Motor Column-Assist EPS (BEPS)
- SbW
- Automated Steering Actuator

All our EPS systems can be tailored with High-Output (HO) capabilities for increased steering capacity and/or High-Availability capabilities for increased safety and lower FIT levels.

### Our EPS & SbW technologies solve OEM challenges across multiple megatrends, including:

- Electrification
- Software/Connectivity
- ADAS/AD
- Shared Mobility

### Major Vehicles Featuring Our EPS Products:

- **HO REPS:** GMC Hummer EV, BrightDrop EV600
- **REPS:**
  - **Ford:** F150, F150 Lightning EV, F150 Raptor, Bronco, Mustang
  - **Stellantis:** RAM 1500, RAM 1500 TRX, Jeep Grand Cherokee
  - **GM:** Chevrolet Silverado, GMC Sierra, Chevrolet Tahoe, GMC Yukon, Cadillac Escalade
  - **Geely:** Zeekr 001 EV
- **SPEPS:** Peugeot 208, Opel Corsa, BMW 1-Series
- **CEPS:** BYD Song Pro/Song Plus, GAC Aion S/Y, Chery Tiggo 8 PHEV
- **BEPS:** BYD Dolphin, RNM Kwid

## Our Products &amp; Technologies

## DRIVELINE SYSTEMS

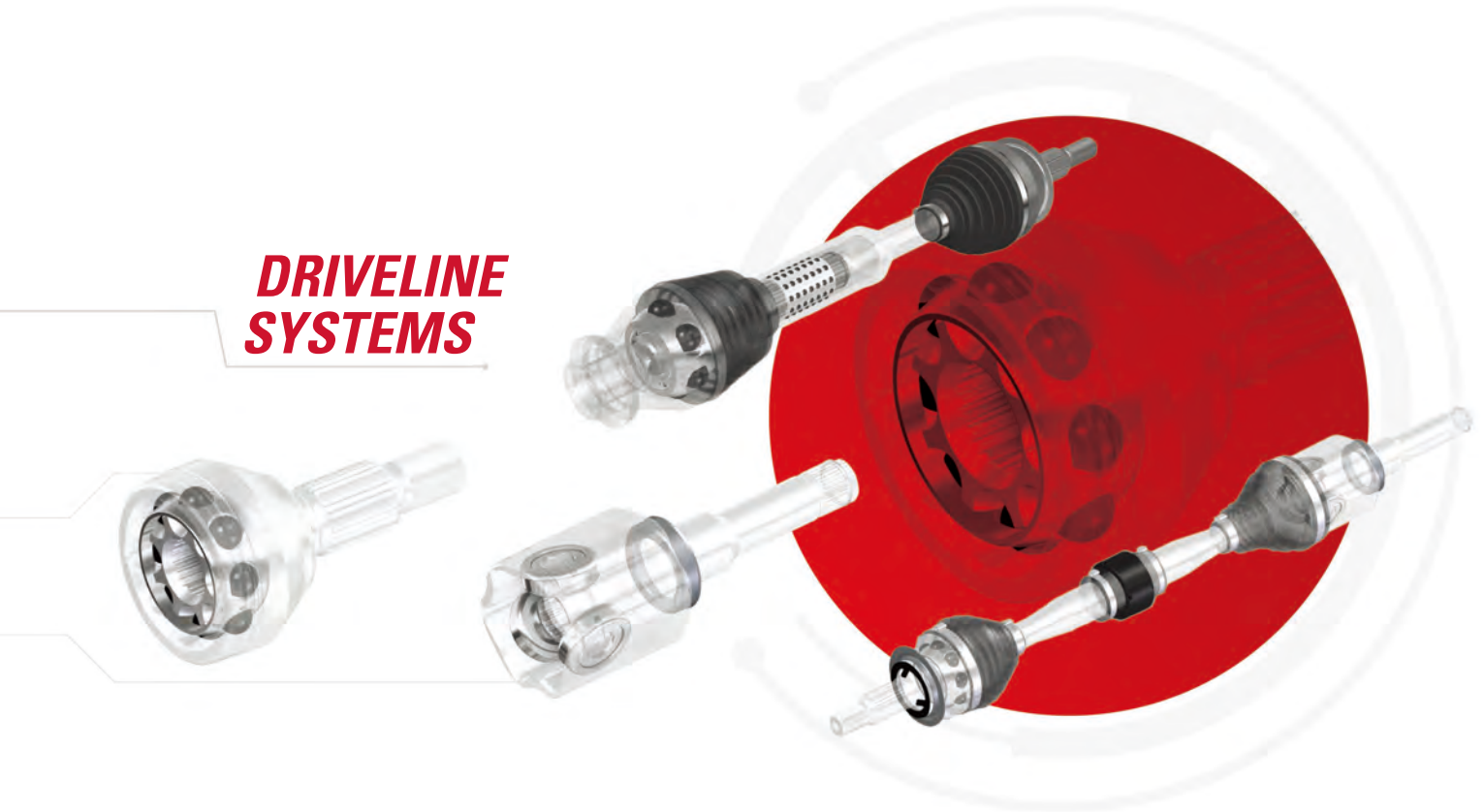

DL systems are designed for a variety of vehicle segments and are custom engineered to meet specific vehicle requirements, transmitting torque from the engine to roadwheels. Our systems enhance vehicle handling and eliminate driveline disturbances on front wheel and all-wheel drive vehicles.

Consequently, Nexteer's halfshafts enhance a driver's comfort and control. Achieving best-in-class comfort and control – especially in terms of DL Noise, Vibration and Harshness (**NVH**) – which becomes even more challenging with EVs that are extremely quiet. Nexteer DL solves for these increased NVH requirements with premium, high efficiency outboard joints, ball spline axles and lower mass components.

Nexteer's wide range of halfshaft technology solutions can accommodate various configurations – and we can also custom-engineer components to meet an OEM's specific needs.

### Nexteer's DL Portfolio:

- Front-Wheel and Rear Wheel Drive Halfshafts for:
  - EVs
  - ICE Vehicles
  - Full-Size Full-Frame Vehicles
  - Performance Vehicles
  - High Angle Requirements
  - High Efficiency Requirements
  - Extreme Operating Environments
- Intermediate Driveshafts

### Our DL technologies solve OEM challenges across multiple megatrends, including:

- Electrification
- ADAS/AD
- Shared Mobility

### Major Vehicles Featuring Our DL Products:

- **GM:** GMC Hummer EV, Cadillac Lyriq EV, Chevrolet Blazer, Chevrolet Equinox, Chevrolet & GMC pickup trucks (LD/HD)
- **Stellantis:** Fiat 500 EV
- **VW:** Jetta, Golf, Taos

## Our Products &amp; Technologies

## STEERING COLUMNS & INTERMEDIATE SHAFTS

CIS connects the steering wheel to the steering mechanism, to control lateral motion by transferring the driver's input torque from the steering wheel. Our advanced steering columns provide convenience features and help protect the driver in the event of a crash. Convenience features include manual and power adjustability, theft deterrence, sensors, actuators and ergonomically designed controls. Advanced energy absorption systems help improve vehicle safety ratings and include our active systems that automatically compensate for the position of the driver to deliver optimum crash protection.

Nexteer offers a wide CIS product portfolio to fit the advanced safety, performance and convenience needs of small cars, SUVs and trucks.

### Nexteer's CIS Portfolio:

- Manual Adjustable Steering Columns
- Power Adjustable Steering Columns
- Stowable Steering Columns
- Crashworthiness – Adaptive Energy-Absorbing Technology
- Integrated Electronics & Sensors
- Security & Transmission Controls
- Wide Intermediate Shaft Portfolio

### Our CIS technologies solve OEM challenges across multiple megatrends, including:

- Electrification
- ADAS/AD
- Software/Connectivity

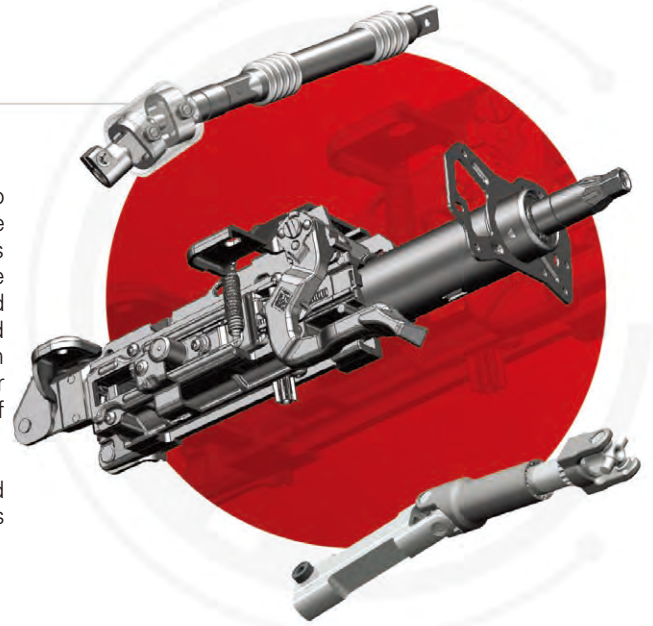

### Major Vehicles Featuring Our CIS Products:

- **Ford:** Bronco, Explorer, Ranger, F150, SuperDuty, Expedition, Econoline, Lincoln Aviator, Lincoln Navigator
- **GM:** Chevrolet Camaro, Chevrolet Colorado, Chevrolet Silverado (LD/HD), Chevrolet Tahoe, Chevrolet Suburban, Chevrolet Express, GMC Canyon, GMC Sierra (LD/HD), GMC Yukon, GMC Savanna, GMC Hummer EV, Cadillac CT4, Cadillac CT5, Cadillac Lyriq EV, Cadillac Escalade
- **Stellantis:** Jeep Wrangler, Jeep Gladiator, Chrysler Pacifica, RAM 1500, RAM Promaster
- **BMW:** 5 Series, 7 Series, iX
- **China OEMs:** Changan, Great Wall, Xpeng

## HYDRAULIC POWER STEERING

HPS uses high pressure fluids to assist driver steering. An engine-driven power steering pump creates system pressure. Pressurised fluid is then routed into a steering gear cylinder that turns the wheels of the vehicle.

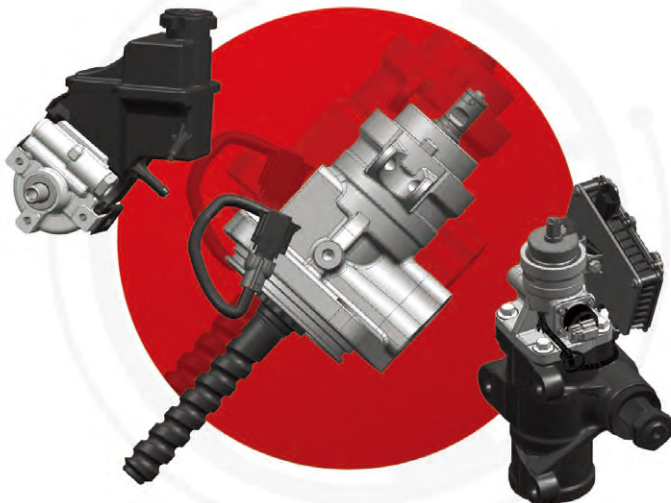

Nexteer produces two premium hydraulic based products: Magnetic Torque Overlay (**MTO**) and Smart Flow pump. These products bring advanced driver assistance functionality with reduced power consumption benefits. The MTO steering gear actuator targets medium and heavy-duty trucks, semi-trailer trucks and buses. The Smart Flow pump reduces parasitic loss on the engine to improve operating efficiency. We also introduced an MTO cartridge valve that enables integration with OEMs' current gear configurations.

### Nexteer's HPS Portfolio:

- MTO
- Rack & Pinion Steering
- Recirculating Ball Steering Gears
- Fuel Efficient Power Steering Gears
- Pumps & Reservoirs

### Major Vehicles Featuring Our HPS Products:

- **GM:** Chevrolet Silverado HD, Chevrolet Express, GMC Sierra HD, GMC Savanna
- **Stellantis:** RAM Promaster
- **Isuzu:** N-Series (Commercial)

## Our Products &amp; Technologies



## SOFTWARE SOLUTIONS

The EVOLUTION from hardware to software-defined vehicles is leading to a REVOLUTION in advanced safety, performance and convenience – transforming OEM expectations and consumer experiences.

Nexteer's steering software enables advanced safety and performance features across all ADAS levels – from optimising steering assist and feel, to enabling driver assist features such as park assist, lane keeping and more – and all the way to fully autonomous driving.

As experts in steering feel, our software gives drivers an immersive steering experience that makes the vehicle come to life in the driver's hands. From sporty to luxury, our software translates a vehicle's brand into something a driver can actually feel. For autonomous applications, software plays a critical role as the vehicle must "feel", translate and anticipate the changing road conditions.

Our software capabilities in a connected environment will create easy, real-time access to new safety, performance and convenience features over the lifetime of a vehicle. For example, using these capabilities, Nexteer's collaboration with Tactile Mobility focuses on both proactive and preventative safety. On the proactive front, our road surface detection software identifies slippery surfaces and gives a "heads-up" communication to trailing vehicles. On the preventative front, software monitors vehicle health – such as tire wear – to ensure safety, performance and convenient maintenance scheduling.

Across all megatrends, a common safety requirement underpins them all – cybersecurity. Nexteer has proactively developed cybersecurity solutions with our OEM customers to ensure that steering systems are safe and protected.



### Nexteer's Software Solutions:

- Software for Advanced Steering
- Road Surface Detection
- Vehicle Health Management
- Brake-to-Steer
- Safety & Cybersecurity

### Our software solutions solve OEM challenges across multiple megatrends, including:

- Electrification
- ADAS/AD
- Software/Connectivity
- Shared Mobility

### Major Vehicles Featuring Our Software:

- All vehicles featuring our EPS also include varying levels of software, software-enabled features and cybersecurity per each of our OEM customers' requirements.
- Nexteer has produced over 90 million EPS systems for vehicles globally.

A grayscale photograph of a woman with curly hair and glasses looking at a man who is pointing at a steering wheel in a car. The scene is framed by a large white circle on a red background with concentric red circles.

# ***BUSINESS OVERVIEW***

## Business Overview

**STRATEGY FOR PROFITABLE GROWTH**

We are committed to our six-point strategy for profitable growth to drive shareholder value and pursue our vision to be the global leading motion control technology company accelerating mobility to be safe, green and exciting. Our strategy for profitable growth served as our guidepost through the unprecedented environment we navigated through during the course of 2020, 2021 and 2022. This strategy continues to guide our daily decision-making as we move forward by defining and adjusting our business to align with the changing landscape and new challenges within the global automotive industry. We integrate our vision and strategy into our day-to-day operations, and we routinely review our strategic goals.

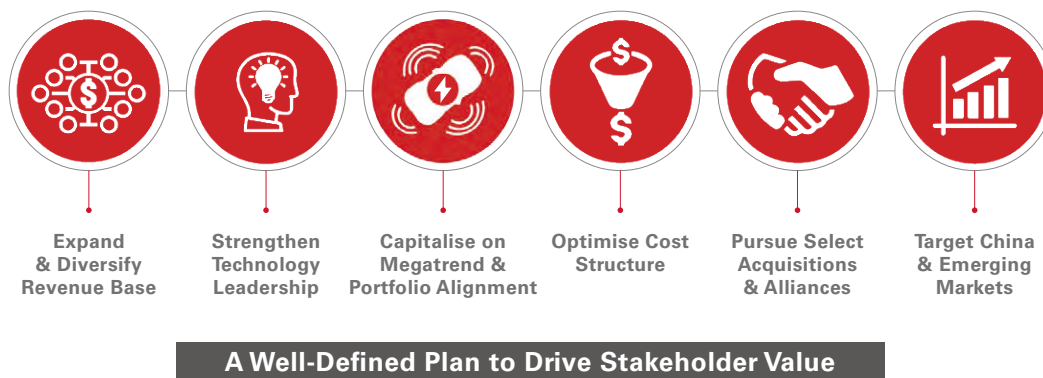
**Strategy for Profitable Growth****2022 BUSINESS HIGHLIGHTS**

The following highlights demonstrate Nexteer's focus on delivering long-term profitable growth:

- Achieved customer programme Bookings totaling US\$6.389 billion for 2022, with US\$2.0 billion of that in the second half of the year
  - o 73% represented new/conquest business, including breakthrough steering wins with a leading global OEM for the industry's first high-volume SbW programme, four new EV truck/SUV programmes in NA and five programme wins with three new Chinese NEV customers
- Successfully launched 42 new customer programmes across all regions – marking another period of strong programme launches
  - o 38 of these customer programmes represented new or conquest business & 16 represented EV launches supported by our products
- Continued commitment to technology leadership and megatrend alignment for future growth – including electrification and software megatrends
  - o Capitalising on our REPS leadership with new EV opportunities in China, leveraging our SbW expertise as OEMs' interest continues to build and aligning with OEMs' growing software needs
- Honoured for innovation, quality, excellence and exceptional customer relationships – including prestigious *Automotive News* PACE and PACEpilot Award Finalists & CES Innovation Award Honoree



## BOOKINGS

### 2022 BOOKINGS: ALIGNED FOR CONTINUED GROWTH

We calculate our revenue bookings (**Bookings**) as the total value of lifetime revenue related to future programmes awarded during the period. A significant factor and input into the calculation of Nexteer's Bookings is forward year OEM production forecasts for awarded customer programmes. In determining forward year OEM production expectations, Nexteer considers reputable third-party automotive production forecasts, customer expectations and internal industry knowledge given past and current trends.

This year was another strong booking period, as our technology continues to be in high demand which will enable us to continue to grow our revenue over market levels. Our megatrend alignment plus our customer, product and market diversification positions us well as we approach a growth wave that will support the Company's mid-term growth when compared with current annual revenue size.

In 2022, Nexteer achieved customer programme Bookings totaling US\$6.389 billion, with US\$2.0 billion of that in the second half of the year.

During this period, 73% of Nexteer's bookings were with our EPS product line, 83% of the bookings will be on fully EV or EV/ICE split platforms and 35% of the bookings align to our Europe, Middle East Africa & South America (**EMEASA**) segment. In addition, 73% of these bookings represent new/conquest business, which provides longer term growth over market for Nexteer. Our EV booking exposure is a strong indication that we are fully consistent with the industry's commitment toward electrification.

A significant booking awarded in the first half of 2022 was the first high volume production of SbW business with a leading global OEM in the industry. It will be a milestone moment to unlock the value of this future steering technology as the lifetime revenue of this booking contract is one of the largest in our Company's history. In addition, more incumbent and potential new customers are showing serious interest in adopting SbW with their next generation vehicles and seeking out Nexteer's leading technology.

Our leadership position in the NA truck/SUV market strengthened further by securing REPS wins on three brand-new BEV truck platforms and one new SUV platform from NA customers in 2022. These business bookings highlight how well Nexteer is positioned in the convergence of electrification and the truck market. We are on both the EV and ICE versions of these programmes, which is important as the mix between powertrains progresses moving forward. Nexteer's steering and DL technologies are also featured on the Ford F-150 Lightning electric truck, the GMC Hummer EV and the upcoming electric Chevrolet Silverado.

Another proof point of our technology alignment with the electrification megatrend is the book of business we are building with local Chinese OEMs that are growing, especially with EVs. For Nexteer, these customers represent a significant opportunity in both electrification and ADAS technologies, and our premium product portfolio is well positioned to support this growth. We have identified extensive opportunities from local Chinese customers for our industry-leading REPS technology, and we see the market experiencing a shift from the traditional CEPS product that has dominated this market in the past because REPS better supports the higher front-axle steering loads and optimises packaging space for these OEMs' new mid-to-large size vehicles and BEVs.

### BREAKTHROUGH WINS

- Industry-first, high-volume SbW programme with leading, global OEM; record-setting lifetime revenue contract
- Four new EV truck/SUV programmes in NA
- NEV wins with leading Chinese OEMs
- First DL win with leading EV OEM
- 73% of bookings represent new/conquest business
- 83% of bookings on EV platforms

Business Overview

To date, we have successfully secured REPS programmes with nine Chinese customers which have or will launch in the next two years, including traditional and NEV customers. Most of our premium REPS products will be equipped in EV models and all will support ADAS Level 3/4 functions. These bookings are deepening our partnership with incumbency OEMs, while allowing us to expand to new local customers by providing industry leading technology. These customers also offer the potential for significant growth as the China market shifts toward EVs, and as some of these local Chinese OEMs have global expansion aspirations.

On the DL front, we continue to add new customers and focus on products that support OEMs’ electrification needs, including NVH performance. In 2022, we secured our first DL win with a leading global EV OEM – adding to the CIS business we won with this OEM last year.

In 2022, Nexteer also celebrated a significant production milestone for our EPS product line – surpassing 90 million EPS systems produced globally. This milestone further highlights our EPS technology and global market leadership.



Bookings is not a measure defined by International Financial Reporting Standards (IFRS), and our methodology for determining Bookings may not be comparable to the methodology used by other companies in determining the value of their bookings. Assumptions relative to estimated lifetime programme volumes and contract performance remain unchanged from our disclosures in prior periods. Any modification, suspension or cancellation of the contracts related to prior year Bookings by the Group’s customers may have a substantial and immediate effect on our ability to actually generate and realise future revenue from these Bookings. While we believe that our current Bookings is a relevant financial metric, we must emphasise that the information set out in this section shall not constitute any forecast or prediction of the revenue and profits of the Group and the actual future value may differ from the estimated Bookings due to various factors beyond the Group’s control.

**SUMMARY OF 2022 BOOKINGS**

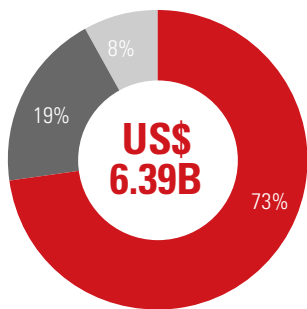

**Bookings by Product Group**

- EPS
- DL
- CIS

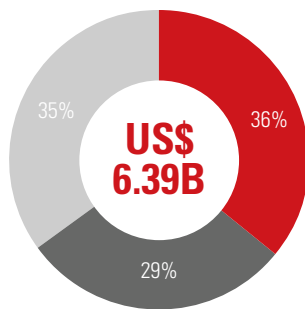

**Bookings by Geographical Segment**

- North America
- Asia Pacific
- Europe, Middle East, Africa and South America

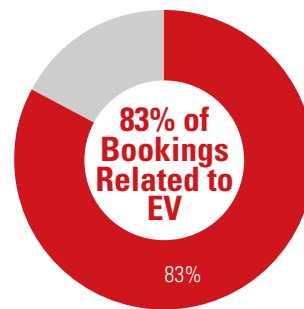

**EV-Related Bookings**

- Estimated % of EPS, CIS and DL bookings for EV\* Applications

\*EV Analysis includes Battery Electric Vehicles (BEVs), Full Hybrid Electric Vehicles (HEVs) and Plug-in Hybrid Electric Vehicles (PHEVs)

## NEW PRODUCTION LAUNCHES

With the launch of 42 customer programmes in 2022, we introduced new or enhanced product applications in steering and DL across all regions and vehicle segments. These programmes represented both global and local vehicle nameplates – of which 38 launches represented new or conquest business and 16 represented EV platforms. Customer programmes that began production in 2022 included:

OEMs	Vehicle Nameplate	Our Products	
<b>North America</b>			
Ford	Ford F-150 Lightning	REPS*, Columns*	
	Ford F-250/F-350 Super Duty	Columns	
<b>EMEASA</b>			
BMW	BMW 7 Series & i7	Intermediate Shafts	
RNM	Renault Express/Kangoo/NV250 EV	Halfshafts*	
	Renault HHA/HJD Captur/Duster Hybrid	Halfshafts*	
Stellantis	Fiat Fastback	CEPS	
	Fiat Cronos/Argo	CEPS	
	Jeep Avenger	PEPS*	
<b>Asia Pacific</b>			
BYD	BYD Frigate 07	CEPS*	
	BYD Seagull	CEPS*	
Changan	Changan UNI-V	CEPS	
	Changan Avatr 11 EV	Columns*	
	Changan BenBen/E-Star	CEPS*	
Chery	Chery Tiggo 8 Pro	eDrive	
Ford	Ford Everest	REPS	
Geely	Geely Smart #1	Halfshafts*	
	Geely Xingyue L Hybrid	Halfshafts*	
	Lynk & Co 01	Halfshafts	
	Lynk & Co 03	Halfshafts	
	Geely Dihao	Halfshafts	
	Geely Boyue Hybrid	Halfshafts	
	GM	Cadillac Lyriq	Columns*, Halfshafts*
		Buick Envista	CEPS, Halfshafts
	Great Wall	Chevrolet Seeker	CEPS, Halfshafts
		Great Wall Kugou	CEPS
Great Wall Tank 500		Columns	
Maruti-Suzuki	Great Wall Lightning Cat	CEPS*	
	Maruti-Suzuki Alto	Halfshafts	
RNM	Nissan X-Trail EV	Halfshafts*	
	Nissan Pathfinder	Halfshafts	
	Infiniti QX60	Halfshafts	
	Mitsubishi Outlander	Halfshafts	
SGMW	Wuling Jiachen	CEPS	
	Wuling Xingchi	CEPS	
	Chevrolet Aveo/Sail	CEPS	
Stellantis	Citroen C3	CEPS	
Xpeng	Xpeng G9	Columns*	
VW	Volkswagen Jetta	Halfshafts	

Note:

\* EV content included in customer programme

## Business Overview

### **MANAGING OPERATIONAL, SUPPLY CHAIN, COMMODITY AND LOGISTICS CHALLENGES**

In 2022, the automotive industry continued to experience significant disruptions driven by ongoing COVID issues, inflationary pressures and global supply chain constraints (e.g., semiconductor chips, etc.), which have been extended from last year, as well as new challenges such as the impacts from the Ukraine Russia War reducing volumes in Europe and increasing energy prices.

While the semiconductor shortages continue to show some signs of improvement, supply remains tight and is likely to continue to remain tight through 2023. Nexteer continues to proactively and diligently work with both our OEM customers and supply partners to minimise the impact of supply shortages to our customers through component substitutions, alternative supply arrangements, throughput improvements and other levers within our control. We continue to closely collaborate, monitor and, as possible, reallocate supply to where needed to best support our customers' production schedules.

In this challenging operating environment, inflationary pressures are also impacting our profit margins, as we are faced with increased input costs for material, labour and other costs but our contractual prices with our customers remains fixed. We continue to work with our customers to recover these cost increases with both contractual escalation agreements and other negotiations.

OEM production volumes increased in the second half of 2022 compared to the first half as consumer demand remained strong and component supply shortages gradually improved. However, Nexteer continues to closely monitor for potential impacts to consumer demand relative to central banks' monetary policies, which are increasing interest rates and contributing to a softening of consumer demand.

In May 2022, freight and commodity prices started to reduce significantly, and these lower costs contributed to improvements of our profit margins in the second half. Compared to the first half of 2022, gross profit rose by 45.1% in the second half; gross profit margin rose by 220 basis points; adjusted EBITDA rose by 30.7%. After experiencing a net loss to equity holders of US\$11.1 million during the first half of 2022, the second half provided a net profit to equity holders of US\$69.2 million, an increase of US\$80.3 million. As we continue to navigate forward through the headwinds imposed on us by the global economic environment, cost discipline and supply chain management remains a top priority.

## TECHNOLOGY LEADERSHIP & PORTFOLIO-TO-TREND ALIGNMENT: ALIGNED FOR CONTINUED GROWTH





Megatrends influencing the automotive market and adjacent sectors continue to represent new and unique channels for Nexteer’s growth. We are well-positioned to support OEMs’ future priorities in these areas.

Nexteer has a robust, proven technology and product portfolio to support industry megatrends such as electrification, software/connectivity, ADAS/AD and shared mobility. Being focused on where the industry is heading, through a strategic alignment on megatrends, contributes to our relevance and will help accelerate our growth.

For example, Nexteer is capitalising on our REPS leadership with new EV opportunities in China, leveraging our SbW expertise as OEMs’ interest in this technology continues to build for EVs and ICE vehicles and aligning with OEMs’ growing software needs for the software-defined vehicle of the future. As proof points, this year we booked the industry’s first high-volume SbW programme with a leading global OEM, four new EV truck/SUV programmes in NA and five programme wins with three new Chinese NEV customers. We also expanded our India Software Centre (ISC) in Bengaluru – adding more software engineering positions to meet OEMs’ growing demand for advanced steering software solutions.

The following sections provide additional details of how these megatrends are evolving and intersecting and how Nexteer is well aligned to these trends. For additional information on our technologies and megatrend alignment, please refer to Nexteer.com.

Beyond these examples and our current product portfolio, Nexteer’s global research and development (R&D) team also continues to explore new ways to further capitalise on megatrends and offer innovative solutions to OEMs’ evolving product challenges.

	 Electrification	 Software & Connectivity	 ADAS & Automated Driving	 Shared Mobility
Electric Power Steering	✓	✓	✓	✓
Steer-by-Wire	✓	✓	✓	✓
Columns & I-Shafts	✓	✓	✓	
Driveline	✓		✓	✓
Software	✓	✓	✓	✓
R&D	✓	✓	✓	✓

Business Overview

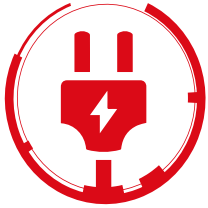

**ELECTRIFICATION**

On the steering front, Nexteer offers advanced steering technologies that are capable of handling EVs’ heavier load requirements, plus packaging and NVH needs.

On the DL front, we provide optimised solutions that include compact and low mass halfshafts.

EV platforms have unique driveline challenges due to their weight, low noise level, high torque, and need for maximum efficiency to support extended battery life. Nexteer offers premium technologies that improve efficiency and NVH performance while delivering maximum torque under extreme acceleration conditions. Our DL technology and decades of vehicle integration experiences has positioned us to be a leader in the expanding EV market.

Nexteer technologies that support the electrification megatrend include, but are not limited to the products listed to the right.

- NEXTEER + ELECTRIFICATION**
- Steer-by-Wire
  - Rack-Assist EPS
  - Dual Pinion-Assist EPS
  - Single Pinion-Assist EPS
  - High Output EPS
  - Automated Steering Actuator
  - Fully Cylindrical Powerpacks
  - High-Angle Intermediate Shafts
  - Premium, Low Mass, Compact Halfshafts
  - High Efficiency Joints
  - Premium TriGlide Joints
  - Double-Offset Joints
  - 48-volt Integrated Belt-Driven Starter Generator eDrive Device



**SOFTWARE & CONNECTIVITY**

The evolution from hardware to software-defined vehicles is leading to a revolution in advanced safety, performance and function.

All Nexteer software solutions start with proven, high-quality safety and cybersecurity. We collaborate with OEMs on software feature development, execution and vehicle integration.

We have in-house ownership of all steering software design content – which drives quality, flexibility, speed and value for our OEM customers. We also collaborate with third-party partners such as Tactile Mobility and others to continuously innovate software solutions.

Nexteer’s software solutions include, but are not limited to the products listed to the right.

- NEXTEER + SOFTWARE / CONNECTIVITY**
- Advanced Steering Software, such as High Availability Steering Technologies
  - Road Surface Detection Software (with Tactile Mobility)
  - Tire Health & Parameter Detection Software (with Tactile Mobility)
  - Brake-to-Steer



**ADAS/AD**

Assisted and AD require high levels of redundancy to ensure the safety net is always on. Through advanced motion control software and technologies, Nexteer enables greater safety, comfort and convenience across all ADAS levels – from traditional hands-on driving to fully automated vehicles with no driver.

Nexteer technologies that support the ADAS megatrend include, but are not limited to the products listed to the right.

- NEXTEER + ADAS**
- EPS
  - SbW
  - Stowable Steering Column
  - Steering Software
  - Brake-to-Steer



**SHARED MOBILITY**

Nexteer’s advanced motion control solutions enable built-in redundancies and higher durability to support autonomous people movers, last mile delivery vehicles and more.

The extra safety layers and durability are especially important in these applications without a human driver, or when the vehicle is running many more hours than typical duty cycles.

Shared mobility is closely connected with other trends like AD, connectivity and electrification – such as with people movers and geofenced last mile delivery vehicles.

- NEXTEER + SHARED MOBILITY**
- Automated Steering Actuator
  - SbW
  - High Availability EPS
  - Advanced Halfshaft Technologies

Nexteer technologies that support the shared mobility megatrend include, but are not limited to the products listed to the right.

**TECHNOLOGY UPDATES**

**DISSOLUTION OF CNXMOTION, LLC JV**

In February 2023, Nexteer and Continental Automotive Systems, Inc. agreed to dissolve their JV, CNXMotion LLC (**CNXMotion**), to reallocate resources in support of shifting business priorities. For example, Nexteer plans to reassign its employees from the JV to help the Company keep pace with growing demand for SbW and software-based technologies. CNXMotion was established in 2017 with the goals to accelerate R&D innovation and integrate steering and braking technologies for motion control. The venture resulted in 60+ records of invention, over 30 patent filings, several patent awards to-date, and software products such as Brake-to-Steer. The parent companies will continue to leverage the successful innovations generated from the JV, as well as consider future project-based collaboration opportunities.

**INTELLECTUAL PROPERTY PROTECTION & TECHNOLOGY**

Nexteer is dedicated to protecting our intellectual property rights, which are crucial to our business growth and our ability to differentiate ourselves from competitors. We actively apply for protection for Nexteer’s intellectual property to guard our exclusive rights. As of December 31, 2022, Nexteer’s global portfolio includes 781 patent applications and 1,230 issued patents. The sustained growth in issued patents is a result of our robust applications in previous years and it demonstrates our efforts for observing and protecting intellectual property rights. In alignment with industry megatrends, 31% of patents granted during 2022 are related to Software-as-a-Product, SbW, and/or ADAS/AD enabling technologies. Additionally, 19% of our 2022 patent filings are directly related to these identified technologies. Our innovative and current patent portfolio is proof of our technological leadership in motion control technology.

## Business Overview

### EMBRACING OUR ENVIRONMENTAL, SOCIAL AND GOVERNANCE (ESG)/SUSTAINABILITY JOURNEY

In addition to product and technology expertise, Nexteer continues to demonstrate industry leadership as a business partner and employer of choice through our commitment to corporate social responsibility.

Through these unprecedented times, Nexteer has adapted quickly by strengthening our focus on employee health and safety and acting with a deeper sense of corporate social responsibility. Inspired by our vision – “we are the leading motion control technology company accelerating mobility to be **safe, green and exciting**”, we continue to identify opportunities to embrace sustainability in our Strategy for Profitable Growth – such as by aligning our innovation and technology with industry megatrends like electrification, by exploring levers with impacts improving operation efficiency and our environmental footprints, as well as by maintaining our commitment to conduct our business ethically and with transparency.

We believe that through sustainable practices, we can continue to improve our performance and provide greater value to our key stakeholders, including shareholders, employees, customers, suppliers, local communities, society and so on. As we advance our ESG journey, we continue to integrate a sustainability mindset into our global business strategies and culture.

## SUSTAINABILITY HIGHLIGHTS FIVE KEY FOCUS AREAS



**BUSINESS ETHICS**



**SUPPLY CHAIN**



**COMMUNITY**



**VALUE CREATION**



**HEALTH, SAFETY  
and ENVIRONMENT**

We publish an annual ESG/Sustainability Report in accordance with the Environmental, Social and Governance Reporting Guide, as set out in Appendix 27 to the Rules Governing the Listing of Securities on The Stock Exchange of Hong Kong Limited (the **Listing Rules**). We invite you to learn more about our culture and the strides we are making to improve our sustainable performance by referencing our Corporate Sustainability information at <https://www.nexteer.com/sustainability/>.

### DEMONSTRATED LEADERSHIP VIA TECHNOLOGY DEMONSTRATIONS & SPEAKING ENGAGEMENTS

In 2022, Nexteer’s industry thought leaders continued to be sought after speakers at high-profile events around the world to discuss the challenges, opportunities and solutions related to industry megatrends and motion control technology leadership.

Nexteer speakers were featured at the following 2022 events:

- Reuters Automotive Europe
- Next Generation Steering Systems USA Summit
- AutoTech: Detroit
- *Automotive News* PACE Innovation Panel
- Society of Automotive Engineers (SAE) WCX™ World Congress Experience
- EcoMotion
- Automotive Steering Systems
- ChassisTech Plus
- 2022 China-SAE Congress & Exhibition



## CUSTOMER & INDUSTRY RECOGNITION

In 2022, Nexteer was honoured for innovation, quality and excellence – as well as for exceptional customer relationships. Here is a summary of achievements:



### Innovation Awards

- 2022 *Automotive News* PACE Finalist for Automated Steering Actuator
- 2022 *Automotive News* PACE Pilot Finalist for Advanced Road Surface Detection & Early, Intuitive Warning Software with Tactile Mobility
- CES® 2023 Innovation Award Honoree in the “Vehicle Tech & Advanced Mobility” product category for our Road Surface Detection & Early, Intuitive Warning Software with Tactile Mobility
- 2022 Frost & Sullivan’s North American Market Leadership Award in Power Steering
- AutoTech Breakthrough Award for “Autonomous Vehicle Innovation of the Year” for our Automated Steering Actuator
- Society of Automotive Analysts’ (SAA) Mobility Innovation Award for “Technologies Enabling New Business Models” for our SbW with Stowable Steering Column
- 2022 *Automobile Industry* Automotive Innovation Technology Award for Automated Steering Actuator
- 2022 *Automobile & Parts* Innovative Technology Award for Automated Steering Actuator
- 2022 *Auto Business Review* China Auto Parts Industry Awards Excellent Award for Automated Steering Actuator

### Supplier Partnership, Quality and Manufacturing Awards

- General Motors’ Supplier of the Year Award – Third Consecutive Year
- General Motors’ Supplier Quality Excellence Award for Nexteer Wuhu (China), Nexteer Queretaro (Mexico) and Nexteer Juarez (Mexico)
- Geely’s Excellent Supplier Team Award for Nexteer Wuhu
- Changan’s Excellent Supplier Award for Nexteer Chongqing (China)
- JMC’s (Ford) Supplier Segment B Certificate for Nexteer Suzhou (China)
- LYNK & CO’s Excellent Supplier Award for Nexteer Wuhu
- Chery’s Excellent Supplier Award for Nexteer Suzhou
- Tata Motor’s 2022 Annual Supplier Conference “GOING EXTRA MILE” Award
- Changan Quality Certification for Nexteer Chongqing
- BYD’s Best Partner Award for Nexteer Liuzhou (China)
- SGM-Dongyue’s Supply Chain Guardian Award for Nexteer Wuhu
- GAC AION’s Excellent Supplier Award for Nexteer Liuzhou
- Two 2022 Manufacturing Leadership Awards from the National Association of Manufacturers for Digital Network Connectivity and Enterprise Integration & Technology – Fifth Consecutive Year

## Business Overview

### Sustainability and People

- Recognised as a constituent member of the Hang Seng Corporate Sustainability Benchmark Index (**HSSUSB**) – Six Consecutive Year
- 2022 Great Place to Work Certification for Nexteer Brasil – Fifth Time since 2017
- 2022 Great Place to Work Certification for Nexteer Morocco – Third Consecutive Year
- 2022 Manpower Award of Great Place to Work for Nexteer Poland – Fifth Consecutive Year
- 51job.com's Top Employer Award for Nexteer China
- Liuzhou Role Model of Comprehensively Deepening Reform for Nexteer Liuzhou
- Wuhu Top 100 Industrial Companies for Nexteer Wuhu
- Suzhou Industrial Park CSR Caring Award for Nexteer Suzhou
- Best Employer Greater Suzhou for Nexteer China
- Extraordinary Employer Jiangsu Province for Nexteer China
- Moka's HR Best Practice in Digitalization Award for Nexteer China
- Government of Anhui Province's Top 50 Companies with Specialization, Refinement, Characteristic and Novelty in Anhui Province for Nexteer Wuhu

Nexteer not only wins industry awards and recognition, but we also help our customers win awards too, including:

2023 MotorTrend Truck of the Year & 2023 North American Truck of the Year™ Ford F-150 Lightning electric truck featuring Nexteer's REPS:

- **REPS:** Enables driver-assist features like lane keeping, auto park assist and more – plus it enables over-the-air software flash updates.

2023 European Car of the Year Jeep® Avenger electric SUV featuring Nexteer's SPEPS

## REGIONAL MARKET HIGHLIGHTS

In 2022, Nexteer continued optimisation of our global manufacturing footprint and technical centres to enhance efficiencies as well as customer and market responsiveness. Nexteer's global footprint includes 26 manufacturing facilities, three technical centres, one software centre and 13 customer service centres. The following is a brief overview of accomplishments by region during 2022.

### NORTH AMERICA (NA)

Throughout the year, our NA segment remained focused on executing flawless programme launches and providing exceptional quality and technical support to our customers, as well as winning future business for our USA and Mexico operations.

In 2022, the NA segment executed three major programme launches, including REPS on the new, award-winning Ford F-150 Lightning electric truck and columns on the Ford F-250/350 Super Duty. With our dedication to launch excellence, Nexteer in Juarez, Mexico and Querétaro, Mexico were both recognised with GM's "Supplier Quality Excellence Award." Nexteer was also recognised with GM's Supplier of the Year Award – for the third consecutive year.

Despite industry challenges, our North America team also recorded new Booking successes with customer programme wins in 2022 totaling US\$2.33 billion – including four new EV truck/SUV programmes from major OEMs.

The collective impact of NA's 2022 programme launches plus carry-over benefit from 2021 launches, enabled the NA segment to achieve a 15.6% increase in revenue when compared with 2021. Adjusting for commodity recoveries, the segment experienced a revenue increase of 14.1%, outperforming the market by 480 basis points.

Beyond fiscal achievements, our innovative technologies were also recognised with several prestigious industry awards:

- **Automated Steering Actuator:** 2022 *Automotive News* PACE Award Finalist & AutoTech Breakthrough Award Winner
- **Advanced Road Surface Detection & Early, Intuitive Warning Software with Tactile Mobility:** 2022 *Automotive News* PACE Pilot Award Finalist & CES® 2023 Innovation Award Honoree
- **SbW with Stowable Steering Column:** SAA Mobility Innovation Award Winner

## Business Overview

In 2022, Nexteer also received a US\$25.5 million investment grant from the Michigan Strategic Fund Board for the Community Development Block Grant Programme and the State Essential Services Assessment. This support will play a critical role in retaining high-quality jobs at our Saginaw, USA site by enabling Nexteer to secure the necessary equipment to maintain world-class manufacturing operations. Demand for Nexteer's advanced, safety-critical steering, DL and software solutions continues to grow amongst our OEM customers, and this investment will enable us to continue developing and manufacturing innovative motion control solutions for future mobility.

**ASIA PACIFIC (APAC)**

The APAC segment successfully launched 33 programmes in the region, covering international OEMs, local OEMs and key NEV customers in 2022. These programme launches, and the carry-over benefit from launches in 2021, enabled the APAC segment to achieve a historical revenue level of US\$965.2 million, an 18.8% increase when compared with 2021. Adjusting for foreign currency and commodity recoveries, the segment experienced a revenue increase of 24.5%, outperforming the market by 1,710 basis points.

In 2022, APAC segment added two new customers and bookings totaled US\$1.8 billion. In addition to incumbent customer programmes, the segment was also awarded several key conquest customer programmes in both EPS and DL business, especially on NEV models, providing further growth opportunities.

The APAC segment continued to develop in-region engineering capabilities benefitting current and future customers as well as fostering an innovative culture and environment throughout the organisation. The local engineering capabilities are further developed and applied in REPS and power column within the APAC segment. In-region SbW technology capabilities are also being developed, to capture future growth opportunities.

In 2022, APAC continued delivering exceptional quality to our customers and contributing economic growth of the local community. Nexteer China has been selected as a member of the Automotive Industry Action Group China Quality Advisory Committee. Nexteer Liuzhou Co., Ltd was awarded Role Model of Comprehensively Deepening Reform in Liuzhou City. Nexteer's JV with Lingyun, Industrial Corp., Ltd., Nexteer Lingyun Driveline (Wuhu) Co., Ltd. was recognised as Wuhu Top 100 Industrial Companies.

The APAC segment also earned a wide range of recognition from customers, government and associations in recognition of innovation, service, Corporate Social Responsibility (CSR) activities and positive social impact. These included: Six customer awards for excellent performance in 2022 from Tata, Chery, Changan, BYD, SGM-Dongyue, GAC Aion; three awards for being an employer of choice; and three awards from leading trade media recognising Nexteer's capabilities in innovation and products, as well as community outreach including the establishment of a fourth Nexteer Library in a rural area in China.

**EUROPE, MIDDLE EAST, AFRICA AND SOUTH AMERICA (EMEASA)**

In 2022, the EMEASA segment continued its growth and product diversification trend by launching six new programmes across all sites, including I-Shafts for the BMW 7-series (ICE and BEV models), CEPS for Stellantis Argo/Cronos and Fiat Fastback, and DL programmes with RNM and Renault. With the 2022 programme launches, EMEASA has further strengthened its position in technology megatrends.

These programme launches, and the carry-over benefit of launches executed in 2021, enabled the EMEASA segment to achieve a 5% increase in 2022 revenue when compared with 2021. We continue to work with European customers such as Stellantis, BMW and RNM to grow our Steering and DL revenue in the region. In addition to successful launches, EMEASA also recorded new Booking successes in 2022 totaling US\$2.2 billion. A critical Booking for the region and the overall Company was the first sale of SbW, which opens the gateway to advanced safety and performance in motion control.

EMEASA's growth engine – the newly established Kenitra, Morocco facility – continued its strong trend of high-volume DL launches while also reaching peak volumes for programmes launched in 2019 and 2020. In 2022, the operation focused on enhancing manufacturing efficiencies while navigating significant customer vehicle production schedule changes resulting from global supply chain constraints.

## Business Overview

The growth of EMEASA was driven by new programmes and product groups, which are mainly developed in the region, the technical development centre in Tychy, Poland and the Customer Service Centres in Germany, France, Italy and Brazil. The strengthening of regional engineering is made possible by the on-going expansion of the development team. With the global design responsibility for pinion-based EPS systems, EMEASA plays an important role in Nexteer's strategic innovation network.

To support EMEASA's growth, the region broke ground on a new facility to expand its technical capabilities and infrastructure at the Tychy, Poland Technical Centre. This expansion, including advanced testing, validation and training will enable the region to drive efficiencies and customer responsiveness with our engineering and software operations and maintain recognition as a great place to work.

Meanwhile in Brazil, volume recovered strongly in 2022 across CEPS, SPEPS and DL.

During 2022, EMEASA also earned multiple recognitions related to its culture, including Manpower Group's Friendly Place to Work for Nexteer Poland and two Great Place to Work® certifications – one for Nexteer Morocco and one for Nexteer Brazil.

Beyond industry recognition, community outreach, volunteering and social responsibility are also natural byproducts of a highly engaging employee culture. In 2022, EMEASA demonstrated its commitment to local communities across six countries through almost 12,000 volunteer hours of charity activities.

## Financial Highlights

Results (US\$'000)	2022	2021	Change
Revenue	<b>3,839,703</b>	3,358,725	14.3%
Gross profit	<b>367,151</b>	363,429	1.0%
Profit before income tax	<b>91,947</b>	114,013	(19.4%)
Income tax (expense) benefit	<b>(26,434)</b>	12,390	313.3%
Profit attributable to equity holders of the Company	<b>58,013</b>	118,440	(51.0%)
Profit for the year	<b>65,513</b>	126,403	(48.2%)
Adjusted EBITDA	<b>364,825</b>	360,763	1.1%

Assets and Liabilities (US\$'000)	2022	2021	Change
Non-current assets	<b>1,843,180</b>	1,846,274	(0.2%)
Current assets	<b>1,492,101</b>	1,360,225	9.7%
Non-current liabilities	<b>331,690</b>	261,783	26.7%
Current liabilities	<b>1,026,441</b>	942,127	8.9%
Capital and reserves attributable to equity holders of the Company	<b>1,933,825</b>	1,954,629	(1.1%)

These financial highlights should be read in conjunction with the Group's consolidated financial statements for the year ended December 31, 2022 (the **Consolidated Financial Statements**).



***MANAGEMENT  
DISCUSSION  
& ANALYSIS***

## Management Discussion and Analysis

The following management discussion and analysis should be read in conjunction with the Consolidated Financial Statements, included herein, which have been prepared in accordance with IFRS as issued by the International Accounting Standards Board.

### FINANCIAL REVIEW

#### Financial Summary

As the automotive industry has entered the third year of impact caused by the COVID-19 pandemic that began in early 2020, the Group continued to experience significant macro-economic headwinds during 2022. Inflationary pressures, supply chain restrictions, increased energy prices and impacts from the Ukraine Russia War have negatively impacted the Group's profit margins despite a considerable growth in revenue when compared with 2021. The Group's revenue increased by 14.3% for the year ended December 31, 2022 compared with 2021, with all three geographical segments positively impacted as OEM vehicle production continues to recover from the adverse operating environment experienced during 2020 as a result of the global pandemic. As reported by IHS Markit Ltd. (January 2023), global OEM vehicle production increased by 6.2% during 2022 when compared with 2021.

The macro-economic headwinds experienced during 2022 resulted in inflationary pressures that increased commodity prices, logistics, energy and other input cost that were not fully offset by customer price increases. Compared with the year ended December 31, 2021, gross profit of US\$367.2 million represents an increase of 1.0%; profit before income tax of US\$91.9 million represents a decrease of 19.4%; profit attributable to equity holders of the Company of US\$58.0 million represents a decrease of 51.0%; and adjusted EBITDA of US\$364.8 million represents an increase of 1.1%.

The deterioration to net profit in 2022 was driven in large by increased income tax expense the Group recorded, in particular within the US operations, in 2022 compared to 2021. During the year ended December 31, 2022, the Group determined that its US net deferred tax assets, mainly R&D credits, were not probable to be fully realised and recorded a decrease in the net deferred tax assets. Consistent with this determination, the Group has not recorded a tax benefit for credits and certain other deferred tax assets generated in 2022 due to US cumulative pre-tax losses. As a result, the Group has not recognised deferred tax assets in respect of tax losses and deductible temporary differences of a net amount of US\$56.7 million during the year ended December 31, 2022, of which US\$58.2 million is attributed to the US operations.

The Group's cash balance of US\$245.9 million as at December 31, 2022 represented a decrease of US\$80.6 million when compared with US\$326.5 million as at December 31, 2021. For the year ended December 31, 2022, the Group's net cash generated from operating activities was US\$293.8 million, an increase of US\$6.4 million compared with US\$287.4 million for the same period in 2021. The increase in cash flows from operations was driven by the net favourable working capital, partially offset by the decrease in earnings for the year ended December 31, 2022 compared with 2021. Cash from operating activities less cash used in investing activities was a source of US\$30.3 million, which compared favourably to a source of US\$1.7 million in the same period of 2021. Cash used in financing activities during the year ended December 31, 2022 was US\$85.2 million, a decrease of US\$130.2 million, when compared with a cash use of US\$215.4 million during the year ended December 31, 2021. The main drivers of the Group's decreased cash used in financing activities included the redemption of the Group's US\$250.0 million 5.875% senior notes due 2021 (**Notes**) during 2021, compared to lower repayments of borrowings in 2022 due to net repayments of the US revolving line of credit, partially offset by new term loans in China totaling US\$50.3 million. The revolving line of credit is used for general working capital requirements, and with improved working capital during the period, the Group had excess cash to pay down the balance.

## Management Discussion and Analysis

A summary comparison of the Group's financial performance for the first half of 2022 compared with the second half of 2022 for selected metrics is provided in the table below:

Results (US\$'000)	H1 2022	H2 2022	Change
Revenue	1,791,067	2,048,636	14.4%
Gross profit	149,813	217,338	45.1%
Gross profit margin (as % of revenue)	8.4%	10.6%	2.2%
Profit attributable to equity holders	(11,138)	69,151	720.9%
Profit margin (as % of revenue)	(0.6%)	3.4%	4.0%
Adjusted EBITDA	158,117	206,708	30.7%
Adjusted EBITDA margin (as % of revenue)	8.8%	10.1%	1.3%
Net increase (decrease) in cash and cash equivalents	7,817	(62,715)	(902.3%)

### Operating Environment

The global automotive market has a direct impact on our business and operating results. Factors affecting the industry include macro-economic influences such as consumer confidence, fluctuations in commodity prices, currency, fuel prices and regulatory environments. The ability to secure material and components from our supply-base is also critical, as evidenced by the semiconductor chip shortage which created a significant industry-wide challenge carrying into 2022. The Group operates primarily in the US, Mexico, China, Poland, India, Morocco and Brazil.

Global OEM light vehicle production regressed slightly during the first six months of 2022 but rebounded by the end of the year providing growth in all segments. Europe provided strong unit growth in the last six months of 2022 when compared to 2021, but did not overcome the lower unit production realised in the first six months. North America, Asia Pacific and South America all benefited from higher production volumes in 2022 when compared to 2021.

According to IHS Markit Ltd. (January 2023), global OEM light vehicle production for the year ended December 31, 2022 was higher than the year ended December 31, 2021, increasing by 6.2%. The change in OEM light vehicle production for the first half, second half and year ended December 31, 2022 compared with the same periods in 2021 for key markets served by the Group is provided in the table below:

	H1 2022	H2 2022	Full-Year 2022
North America	4.4%	14.8%	9.3%
China	1.1%	10.6%	6.2%
India	17.2%	27.8%	23.8%
Europe	(11.3%)	12.3%	(0.7%)
South America	(0.5%)	20.4%	11.1%

The Group conducts its business from a global operating footprint to service its broad customer base and, accordingly, the financial results of the business are impacted by changes in foreign currencies measured against the US dollar, principally the European euro (**Euro**) and the Chinese renminbi (**RMB**). The Group's revenue was unfavourably impacted by foreign currency translation as the US dollar strengthened against both the Euro and RMB during the year ended December 31, 2022 compared with the same period a year ago. The Group's financial results experienced an unfavourable impact to profit due to unrealised exchange gains on foreign exchange transactions.

During the year ended December 31, 2022, the Group successfully launched 42 new customer programmes – 33 programmes in Asia Pacific, 6 programmes in EMEASA and 3 programmes in North America. Of the 42 customer programme launches, 38 represented new conquest business for the Group, 4 represented incumbent business and 16 represented EV programmes.



## Management Discussion and Analysis

**Revenue**

The Group's revenue for the year ended December 31, 2022 was US\$3,839.7 million, an increase of US\$481.0 million, or 14.3%, compared with US\$3,358.7 million for the year ended December 31, 2021. Increased OEM light vehicle production and significant new and conquest programme launches over the past few years were the principal drivers for higher revenue for 2022 when compared with 2021. Unfavourable foreign currency translation tempered the Group's revenue increase by approximately US\$116.6 million, impacting both the Asia Pacific and EMEASA segments, given the strengthening of the US dollar against both the RMB and Euro during the 2022 compared with a year ago. Customer recoveries, resulting from the pass through of raw material commodity increases, improved revenue during 2022 by approximately US\$57.7 million. Adjusting for unfavourable foreign currency translation and the increases related to commodity recoveries, the Group's revenue rose by 16.1% in 2022 compared with 2021, outpacing the revenue increase in OEM production for served markets for the comparative period by 990 basis points. This performance reflected the on-going benefit from the launch of new and conquest customer programmes in recent years and favourable vehicle mix.

We measure the results of our operations by geographic segment regions. The change in revenue is analysed by volume, mix, price and foreign currency translation impact. Volume measure changes are driven by the volume of products sold and mix changes are driven by the type of products sold. Price measures the impact of changes within the pricing structure of each product sold. The impact of foreign currency translation is measured by the changes in foreign currencies measured against the US dollar.

**Revenue by Geographical Segments**

The following table sets forth revenue by geographic segments for the years indicated:

	For the year ended December 31, 2022		For the year ended December 31, 2021	
	US\$'000	%	US\$'000	%
North America	2,247,074	58.5	1,944,208	57.9
Asia Pacific	965,188	25.2	812,493	24.2
EMEASA	619,178	16.1	589,243	17.5
Other	8,263	0.2	12,781	0.4
<b>Total</b>	<b>3,839,703</b>	<b>100.0</b>	3,358,725	100.0

Note:

- The change to the segment structure, effective from January 1, 2022, is disclosed further in note 5 to the Consolidated Financial Statements. Comparative amounts for the year ended December 31, 2021 have been restated to conform to current year presentation.

The changes in revenue by geographical segments are primarily due to the following:

- North America segment – Revenue increased by US\$302.9 million, or 15.6%, for the year ended December 31, 2022 compared to the year ended December 31, 2021. The most significant factor contributing to the revenue increase was the improvement in the demand environment, with North America OEM light vehicle production for the year ended December 31, 2022 increasing by 9.3% compared with 2021. Revenue increased due to net price increases to offset inflationary cost pressures. Customer commodity recoveries related to raw material commodities inflation amounted to US\$29.5 million during 2022 compared to 2021.

## Management Discussion and Analysis

- Asia Pacific segment – Revenue increased by US\$152.7 million, or 18.8%, for the year ended December 31, 2022 compared to the year ended December 31, 2021. Contributing to the revenue increase was higher OEM light vehicle production, with total Asia Pacific OEM production volumes higher by 7.4%, and China and India OEM production volumes higher by 6.2% and 23.8%, respectively, for the year ended December 31, 2022 compared with 2021. In addition to the improvement in the demand environment, the segment continued to benefit from new and conquest customer programme launches. Unfavourable foreign currency translation tempered the revenue increase in the Asia Pacific segment in the amount of US\$54.5 million as the US dollar strengthened against the RMB and customer commodity recoveries related to raw material commodities inflation amounted to US\$8.2 million during 2022 compared with 2021. Adjusting for foreign currency translation and customer commodity recoveries, Asia Pacific adjusted revenue increased by 24.5% compared to the change in OEM customer production of 7.4%, outperforming the market by 1,710 basis points.
- EMEASA segment – Revenue increased by US\$29.9 million, or 5.1%, for the year ended December 31, 2022 when compared with the year ended December 31, 2021. Although OEM light vehicle production in the EMEASA segment fell during the first six months, the full year rebounded by 0.9% during the year ended December 31, 2022 compared with 2021. The biggest contributor to the Group’s increased revenue in the segment was the increase in South America OEM light vehicle production of 11.1%, tempered by a decrease in European OEM production of 0.7%. The segment also benefited from on-going customer programme growth in the segment’s Morocco manufacturing facility, which began production in 2019, which increased revenue by US\$19.9 million compared with a year ago. Unfavourable foreign currency translation tempered the revenue growth by the amount of US\$62.1 million as the US dollar strengthened against the Euro and customer commodity recoveries related to raw material commodities inflation amounted to US\$20.0 million during the year ended December 31, 2022 compared with 2021. Adjusting for foreign currency translation and customer commodity recoveries, EMEASA adjusted revenue increased by 12.2% compared to the change in OEM customer production of 0.9%, outperforming the market by 1,130 basis points.
- Other – Revenue decreased by US\$4.5 million, or 35.3% for the year ended December 31, 2022 compared with the same period of 2021. Other revenue is related to non-production engineering design and development/prototype services. The decrease is primarily a result of less prototype expense reimbursement received from customers.

### Revenue by Products

The following table sets forth the Group’s revenue by product lines for the years indicated:

	For the year ended December 31, 2022		For the year ended December 31, 2021	
	US\$'000	%	US\$'000	%
EPS	2,618,330	68.2	2,325,546	69.2
CIS	369,691	9.6	317,786	9.5
HPS	166,151	4.3	136,948	4.1
DL	685,531	17.9	578,445	17.2
	<b>3,839,703</b>	<b>100.0</b>	3,358,725	100.0

The Group experienced an increase in EPS revenue of US\$292.8 million, or 12.6%, for the year ended December 31, 2022 compared with 2021, driven by increased OEM light vehicle production in the North America and Asia Pacific segments. CIS revenue increased by US\$51.9 million, or 16.3% for the year ended December 31, 2022 compared with a year ago. HPS revenue increased by US\$29.2 million, or 21.3% for the year ended December 31, 2022 compared with 2021. DL revenue increased by US\$107.1 million, or 18.5% for the year ended December 31, 2022 compared with last year, as a result of higher OEM light vehicle production in North America.

## Management Discussion and Analysis

**Net Profit Attributable to Equity Holders**

The Group's net profit attributable to equity holders of the Company for the year ended December 31, 2022 was US\$58.0 million or 1.5% of total revenue, a decrease of US\$60.4 million, or 51.0%, compared to US\$118.4 million, or 3.5% of total revenue for the year ended December 31, 2021. The decrease was principally attributable to the following factors:

- The Group has not recognised deferred tax assets in respect of tax losses and deductible temporary differences of a net amount of US\$56.7 million during the year ended December 31, 2022, of which US\$58.2 million is attributed to the US operations.
- Although revenue increased during the year ended December 31, 2022 when compared with a year ago, earnings were significantly deteriorated by several factors which impacted the automotive industry broadly including raw material commodity inflation, increases in transportation and logistics costs, operating inefficiencies arising from increasing supply chain constraints, most notable semiconductor chip shortages, and other factors that continued during 2022.
- Inflationary pressures on manufacturing costs, in the areas of labour, benefits, energy costs and employee related taxes, dampened earnings across all of the Group's segments for the year ended December 31, 2022 when compared with a year ago.

**Cost of Sales**

The Group's cost of sales for the year ended December 31, 2022 was US\$3,472.6 million, an increase of US\$477.3 million, or 15.9%, from US\$2,995.3 million for the year ended December 31, 2021.

Raw material costs represent a significant portion of the Group's total cost of sales and for the year ended December 31, 2022 totaled US\$2,562.4 million, or 66.7% of revenue, compared with US\$2,101.4 million, or 62.6% of revenue, for 2021, reflecting an increase of US\$461.0 million, or 21.9%. The increase in raw material costs for 2022 when compared with a year ago, is attributable to the increase in revenue and the macro-economic factors currently faced by the automotive supplier industry. The main factors contributing to the increase in raw materials include raw material commodity inflation, increased transportation and logistics costs and net increase in material purchase prices due to inflationary pressures. The cost pressures were experienced during 2021, but have continued to increase during 2022, augmenting the contraction of the Group's gross profit margin.

Depreciation and amortisation, including amortisation of capitalised product development costs, charged to cost of sales for the year ended December 31, 2022 was US\$247.7 million, an increase of US\$17.3 million, or 7.5% from US\$230.4 million for the year ended December 31, 2021.

Amortisation of capitalised product development costs recorded as cost of sales amounted to US\$120.5 million for the year ended December 31, 2022, representing 3.1% of revenue, an increase of US\$16.5 million, or 15.9%, from US\$104.0 million, representing 3.1% of revenue, for the year ended December 31, 2021. We expect amortisation to continue to increase in future years with the launch of new customer programmes that are currently in development.

Excluding raw material costs and depreciation and amortisation and fixed and intangible asset impairments, remaining manufacturing costs of US\$662.4 million, or 17.3% of revenue for the year ended December 31, 2022 were lower by US\$1.1 million, or 0.2%, when compared with US\$663.5 million, or 19.8% of revenue, for one year ago. While raw material cost increases continued to place pressure on the Group's gross profit margin, indirect cost savings and discipline helped to limit the impact to the increases in direct costs.

As a percent of revenue, cost of sales increased to 90.4% for the year ended December 31, 2022 compared with 89.2% a year ago.

## Management Discussion and Analysis

### Gross Profit

The Group's gross profit for the year ended December 31, 2022 was US\$367.2 million, an increase of US\$3.8 million, or 1.0%, from US\$363.4 million for the year ended December 31, 2021. Gross profit margin for the year ended December 31, 2022 was 9.6% compared with 10.8% for the year ended December 31, 2021. The decrease in gross profit margin was attributable to inflationary pressures impacting the industry, as described in the preceding cost of sales narrative.

### Engineering and Product Development Costs

For the year ended December 31, 2022, the Group's engineering and product development costs charged to the income statement were US\$145.1 million, representing 3.8% of revenue, an increase of US\$28.8 million, or 24.8%, as compared to US\$116.3 million, or 3.5% of revenue for the year ended December 31, 2021. The Group recognised a product development intangible asset impairment within engineering and product development costs of US\$9.3 million in 2022 related to programme cancellations and declining volumes on specific customer programmes, with US\$9.2 million recorded in the North America segment and US\$0.1 million recorded in the Asia Pacific segment. For the year ended December 31, 2021, the Group recognised a net reversal of product development intangible asset impairment of US\$7.2 million. The Group recorded a customer recovery from a previously impaired programme of US\$8.7 million, with US\$5.3 million recorded in the North America segment and US\$3.4 million recorded in the EMEASA segment, partially offset by the Group recording impairment of US\$1.5 million related to programme cancellations and declining volumes in the Asia Pacific segment and the North America segment in the amount of US\$0.5 million and US\$1.0 million, respectively. The intangible asset impairments recorded in the North America segment were a result of the Group's US domiciled intellectual property holdings arrangement.

Capitalised interest related to engineering development costs totalled US\$6.8 million for the year ended December 31, 2022 and US\$9.7 million for the year ended December 31, 2021. Depreciation and amortisation charged to engineering and product development costs for both years ended December 31, 2022 and 2021 was US\$12.0 million.

The Group's aggregate investment in engineering and product development costs is defined as the sum of costs charged to the consolidated income statement (excluding impairment charges associated with costs capitalised in prior periods) and total costs capitalised as intangible assets during the current period which will be amortised in future periods upon launch and start of production of related customer programmes currently in development. For the year ended December 31, 2022, the Group incurred an aggregate investment in engineering and product development costs of US\$288.9 million, an increase of US\$17.7 million, or 6.5%, compared with US\$271.2 million for the year ended December 31, 2021.

### Selling, Distribution and Administrative Expenses

The Group's selling, distribution and administrative expenses for the year ended December 31, 2022 were US\$150.7 million, representing 3.9% of revenue, an increase of US\$1.7 million, or 1.1%, as compared to US\$149.1 million, or 4.4% of revenue, for the year ended December 31, 2021. Depreciation and amortisation charged to administrative expense for the year ended December 31, 2022 was US\$9.5 million, a decrease of US\$0.8 million, or 7.8%, from US\$10.3 million for the year ended December 31, 2021.

### Other Gains, net

Other gains, net represents gains attributable to foreign exchange transactions, losses on disposal of property, plant and equipment and others. Other gains, net for the year ended December 31, 2022 was a gain of US\$15.0 million, a decrease of US\$2.1 million compared to a gain of US\$17.1 million for the year ended December 31, 2021.

## Management Discussion and Analysis

**Finance Income/Finance Costs**

Finance costs, net, consist of finance income and costs reduced by interest capitalised on qualifying assets and product development. The Group's net finance income for the year ended December 31, 2022 was US\$5.0 million, as compared to net finance costs of US\$1.9 million from the year ended December 31, 2021. The net finance income during the year ended December 31, 2022, when compared with the net finance cost in 2021 can be attributed to:

- Early redemption of the Group's outstanding Notes in the amount of US\$250.0 million, partially offset by new borrowings of term loans in China totaling US\$50.3 million and payable in three tranches.
- Net repayments on the US revolving credit facility during the year ended December 31, 2022 along with interest income accrued on US income tax receivables resulted in lower net finance costs.

**Share of Results of Joint Ventures**

Share of results of joint ventures relates to the Group's investments in Chongqing Nexteer Steering Systems Co., Ltd. (**Chongqing Nexteer**), Dongfeng Nexteer Steering Systems (Wuhan) Co., Ltd. (**Dongfeng Nexteer**) and CNXMotion. For the year ended December 31, 2022, the Group's share of results of joint ventures amounted to US\$4.3 million, (US\$0.7 million) and (US\$3.0 million) related to Chongqing Nexteer, Dongfeng Nexteer and CNXMotion, respectively (year ended December 31, 2021: US\$3.7 million, US\$0.0 million and (US\$3.0 million)). Chongqing Nexteer's profitability during the year ended December 31, 2022 increased slightly when compared with 2021. Subsequent to December 31, 2022, in separate agreements, Nexteer agreed with its joint venture partners of Dongfeng Nexteer and CNXMotion to dissolve both entities. Dissolution of both entities are expected to be completed by the end of 2023.

**Income Tax (Expense) Benefit**

The Group's income tax expense was US\$26.4 million for the year ended December 31, 2022, representing 28.8% of the Group's profit before income tax, compared with an income tax benefit of US\$12.4 million, or 10.9% of profit before income tax, for the year ended December 31, 2021. During the year ended December 31, 2022, the Group determined that its US net deferred tax assets, mainly R&D credits, were not probable to be fully realised and recorded a decrease in the net deferred tax assets. Consistent with this determination, the Group has not recorded a tax benefit for credits and certain other deferred tax assets generated in 2022 due to US cumulative pre-tax losses. As a result, the Group has not recognised deferred tax assets in respect of tax losses and deductible temporary differences of a net amount of US\$56.7 million during the year ended December 31, 2022, of which US\$58.2 million is attributed to the US operations.

The CARES Act was passed by US Congress and signed into law on March 27, 2020. The CARES Act provided for a carryback of any net operating loss (**NOL**) arising in a taxable year beginning after December 31, 2017, and before January 1, 2021, to each of the five taxable years preceding the taxable year in which the loss arises (**Carryback Period**). As a result of this provision, taxpayers take into account such NOLs in the earliest taxable year in the Carryback Period, carrying forward unused amounts to each succeeding taxable year. The Group has applied this provision to its tax calculation and recognised a benefit for the NOL carryback for the year ended December 31, 2021.

**Provisions**

As at December 31, 2022, the Group had provisions for litigation, environmental liabilities, warranties and decommissioning of US\$93.7 million, an increase of US\$15.7 million as compared to US\$78.0 million as at December 31, 2021. The increase in provisions was principally due to the net change in warranty reserves, reflecting net additions of US\$21.2 million, partially offset by US\$16.6 million in cash payments on historical warranty provisions during 2022, and net increase in litigation provisions of US\$12.4 million.

## Management Discussion and Analysis

### Liquidity and Capital Resources

#### Cash Flows

Our business requires a significant amount of working capital, which is primarily used to finance the purchase of raw materials, capital spending for customer programmes and engineering and product development costs. We have historically met our working capital and other capital requirements principally from cash generated from operations and borrowings from third-party financial institutions. We utilise a combination of strategies, including intercompany dividends, intercompany loan structures and other distributions and advances to provide the funds necessary to meet our global liquidity needs. The Group utilises a global cash pooling arrangement to consolidate and manage our global cash balances, which improves cash management efficiency. We believe that cash on hand and availability of borrowings under the Group's existing credit facilities will be adequate to fund our operations.

The following table sets forth a consolidated statement of cash flows for the Group for the years indicated:

	For the year ended December 31, 2022 US\$'000	For the year ended December 31, 2021 US\$'000
Cash generated from (used in):		
Operating activities	<b>293,756</b>	287,383
Investing activities	<b>(263,474)</b>	(285,664)
Financing activities	<b>(85,180)</b>	(215,448)
Net decrease in cash and cash equivalents	<b>(54,898)</b>	(213,729)

#### Cash Flows Generated from Operating Activities

For the year ended December 31, 2022, the Group's net cash generated from operating activities was US\$293.8 million, an increase of US\$6.4 million compared with US\$287.4 million for the year ended December 31, 2021. The increase in cash flows from operating activities was primarily attributable to net favourable working capital in 2022 despite slightly lower earnings in 2022 when compared with 2021.

#### Cash Flows Used in Investing Activities

The Group's cash flows used in investing activities primarily reflect capital spending for purchases of machinery, equipment and tooling and capitalised engineering and product development costs as intangible assets to support customer programmes.

The following table sets forth the cash used in investing activities within the Group for the years indicated:

	For the year ended December 31, 2022 US\$'000	For the year ended December 31, 2021 US\$'000
Purchase of property, plant and equipment	<b>(120,343)</b>	(141,601)
Addition of intangible assets	<b>(146,380)</b>	(146,679)
Other	<b>3,249</b>	2,616
Net cash used in investing activities	<b>(263,474)</b>	(285,664)

## Management Discussion and Analysis

*Cash Flows Used in Financing Activities*

For the year ended December 31, 2022, the Group's net cash flow used in financing activities was US\$85.2 million, a decrease of US\$130.2 million compared with US\$215.4 million for the year ended December 31, 2021. The principal driver of the decrease in net cash used in financing activities was the net repayments of borrowings during the year, specifically the net repayments on the US revolving line of credit, partially offset by new term loans in China. During 2021, the early redemption of the Group's outstanding Notes of US\$250.0 million in April 2021, partially offset by net borrowings on the US revolving credit facility of US\$85.0 million resulted in net repayments. Net cash flows used in (provided by) financing activities for 2022 included the net repayment of borrowings of US\$29.5 million, repayments of lease liabilities of US\$14.4 million, finance costs paid of US\$9.6 million, dividends paid to shareholders of the Company of US\$23.8 million and dividends paid to non-controlling interests of US\$7.8 million.

**Indebtedness**

As at December 31, 2022, the Group's total borrowings was US\$49.8 million, a decrease of US\$34.6 million from US\$84.4 million as at December 31, 2021. This decrease was primarily due to the net repayments under the US revolving line of credit, partially offset by new term loan borrowings in China totaling US\$50.3 million, repayable in three tranches ranging from December 2024 to April 2025. The revolving line of credit is used for general working capital requirements, and with improved working capital during the period, the Group had excess cash to pay down the balance.

The following table sets forth the balances of short and long-term borrowing obligations within the Group for the years indicated:

	<b>December 31, 2022 US\$'000</b>	December 31, 2021 US\$'000
Current borrowings	–	84,403
Non-current borrowings	<b>49,838</b>	–
Total borrowings	<b>49,838</b>	84,403

The table below sets forth the maturity profile of borrowings within the Group for the years indicated:

	<b>For the year ended December 31, 2022 US\$'000</b>	For the year ended December 31, 2021 US\$'000
Within 1 year	–	84,403
Between 1 and 2 years	<b>14,112</b>	–
Between 2 and 5 years	<b>35,726</b>	–
Total borrowings	<b>49,838</b>	84,403

Details of the borrowings of the Group during the year are set out in note 16 to the Consolidated Financial Statements.

## Management Discussion and Analysis

### Pledge of Assets

The Group has several secured borrowings at certain subsidiaries. Assets securing the borrowings differ by site and include accounts receivable, inventories, property, plant and equipment. As at December 31, 2022, the Group had approximately US\$851.2 million total assets pledged as collateral, an increase of US\$37.8 million as compared with US\$813.4 million as at December 31, 2021. The increase in collateral pledged was directly related to increases in the balances of the underlying assets pledged. No significant changes in collateral arrangements have occurred from December 31, 2021 to December 31, 2022.

### Exposure to Currency Rate Fluctuations and Related Hedges

The Group seeks to limit its foreign currency exposure through matching its purchase of materials and sale of finished goods in the same currencies subject to sourcing constraints. The Group monitors its remaining foreign currency exposure regularly to reduce the risk of foreign currency fluctuations in its operations.

### Gearing Ratio

The Group monitors capital structure on the basis of the gearing ratio. The gearing ratio is calculated as total borrowings divided by total equity at the end of the respective year.

The gearing ratio as at December 31, 2022 was 2.5%, a decrease of 170 basis points as compared to 4.2% as at December 31, 2021. The gearing ratio improved as a result of lower borrowings at a higher rate than the reduction in total equity as at December 31, 2022 mainly due to significant changes in the foreign exchange reserve during the year ended December 31, 2022.

### COVID-19 and Related Factors Impacting Operations and Financial Performance

The global automotive industry continued to be impacted by the COVID-19 pandemic throughout 2022, particularly a result of supply shortages as OEM production demand continued to recover. The most significant supply shortage relates to semiconductor chips, which is impacting global industry production, and resulting in significant cancellations of planned OEM production. Supply shortages and the on-going volatility in OEM production schedules adversely impacted our manufacturing and material efficiencies in 2022. In addition, increases in certain commodity and logistics costs had an adverse impact on our operating results for the year ended December 31, 2022. It is possible a resurgence of the COVID-19 pandemic could result in adverse impacts in the future. Management cannot reasonably estimate the full impact the COVID-19 pandemic could have on the Group's financial condition, results of operations or cash flows in the future.

## OTHER INFORMATION

### Future Prospects

The Group strives to maintain a market-leading position in global advanced steering and driveline systems, including electrification, software and driver-assist and ADAS-enabling technologies. We boost our current position and future prospects by leveraging the following five Nexteer differentiators:

1. Relentless innovation
2. Depth and breadth of our product portfolio
3. Systems integration experience
4. In-house ownership of R&D and integrated product and process development
5. Global manufacturing footprint and prowess



## Management Discussion and Analysis

Megatrends influencing the automotive industry and adjacent sectors, such as Last-Mile-Delivery, continue to present new and unique channels for Nexteer. We retain thoughtful alignment across our product lines with megatrends including ADAS – Advanced Safety & Performance, Software, Electrification, Mobility-as-a-Service and Connectivity. In many cases, our technologies create a natural fit for Nexteer to offer solutions to OEMs across these megatrends, which provides us a competitive advantage and positions us well for potential future opportunities as these megatrends continue to evolve and mature.

Please refer to the Business Overview section earlier in this report for more details on our alignment to these megatrends.

### **Employees and Remuneration Policy**

As at December 31, 2022, the Group had approximately 12,600 full-time employees. The Group's remuneration policies are formulated based on the performance of individual employees and the Group's performance and are reviewed regularly. Our full-time employees participate in various employee benefit plans including retirement benefits, extended disability benefits and workers' compensation. In addition, we have adopted employee incentive plans designed to attract, retain, motivate and encourage employees to commit to enhancing value for us and our shareholders as a whole. For example, the Group has retention programmes that include individual development plans, merit wage adjustments, annual incentive plans and promotions. We offer training programmes to our full-time employees and contract personnel which are designed to develop the skills that we need to meet our enterprise goals and customer requirements and to meet certain training requirements such as mandated customer or regulatory requirements and contractual obligations.

The Group also uses contract personnel to support the workload of the business where considered the most efficient. As at December 31, 2022, we had approximately 1,600 personnel engaged on a contract basis.

### **FORWARD-LOOKING STATEMENTS**

Any forward-looking statements and opinions contained within this Annual Report are based on current plans, estimates and projections, and therefore involve risks and uncertainties. Actual results may differ materially from expectations discussed in such forward-looking statements and opinions. The Company, the Directors and the employees of the Company assume (a) no obligation to correct or update the forward-looking statements or opinions contained in this Annual Report; and (b) no liability in the event that any of the forward-looking statements or opinions do not materialise or turn out to be incorrect.

# Directors and Senior Management

## DIRECTORS

The Board is responsible and has general powers for the management and conduct of our business. The following table sets out certain information concerning the Directors of the Company (the **Directors**) during the year ended December 31, 2022 and as at the date of this annual report:

Name	Age	Position title	Date of appointment(s)	Roles and responsibilities
<b>Executive Directors</b>				
LEI, Zili (雷自力) <sup>(1)</sup>	52	Executive Director, Chief Executive Officer and Chairman	June 21, 2022, June 21, 2022 and March 16, 2022 (formerly non-Executive director on June 8, 2021)	Overseeing our Group's strategic vision, direction and goals and overseeing the overall execution of our Group's strategy
MILAVEC, Robin Zane	55	Executive Director and President, Chief Technology Officer & Chief Strategy Officer	June 30, 2020, August 17, 2021 (formerly Senior Vice President on July 1, 2019) and July 1, 2019, respectively	Responsible for integrating corporate strategy, Global Engineering
ZHAO, Guibin (趙桂斌) <sup>(2)</sup>	58	Executive Director, Chief Executive Officer and Vice Chairman	June 15, 2013, June 2012 and June 3, 2019 (formerly Chairman on June 15, 2013), respectively	Overseeing our Group's strategic vision, direction and goals and overseeing the overall execution of our Group's strategy
FAN, Yi (樊毅) <sup>(3)</sup>	56	Executive Director, Vice President and Company Secretary	August 21, 2012, November 14, 2013 and October 19, 2018, respectively	Managing our Group's operations and handling of company secretarial duties
<b>Non-Executive Directors</b>				
WANG, Jian (王堅)	61	Non-Executive Director	June 3, 2019	As a non-Executive Director
ZHANG, Wendong (張文冬)	46	Non-Executive Director	November 13, 2020	As a non-Executive Director
SHI, Shiming (石仕明)	43	Non-Executive Director	June 21, 2022	As a non-Executive Director
<b>Independent Non-Executive Directors</b>				
LIU, Jianjun (劉健君)	54	Independent non-Executive Director	June 15, 2013	As an Independent non-Executive Director
WANG, Bin (王斌)	57	Independent non-Executive Director	June 21, 2022	As an Independent non-Executive Director
YUE, Yun (岳雲)	52	Independent non-Executive Director	June 21, 2022	As an Independent non-Executive Director
WEI, Kevin Cheng (蔚成) <sup>(4)</sup>	55	Independent non-Executive Director	June 15, 2013	As an Independent non-Executive Director
YICK, Wing Fat Simon (易永發) <sup>(5)</sup>	64	Independent non-Executive Director	August 15, 2017	As an Independent non-Executive Director

### Notes:

- (1) Mr. LEI, Zili (雷自力), was appointed as a non-Executive Director and a member of the Audit and Compliance Committee with effect from June 8, 2021. Mr. LEI was appointed as Chairman of the Board and ceased to be a member of the Audit and Compliance Committee with effect from March 16, 2022. Mr. LEI was re-designated from a non-Executive Director to an Executive Director and appointed as Chief Executive Officer with effect from June 21, 2022.
- (2) Mr. ZHAO, Guibin ceased to act as Executive Director, Chief Executive Officer and Vice Chairman with effect from June 14, 2022.
- (3) Mr. FAN, Yi ceased to act as Executive Director with effect from June 21, 2022 and as Vice President and Company Secretary with effect from June 30, 2022.
- (4) Mr. WEI, Kevin Cheng (蔚成) ceased to act as an Independent non-Executive Director and the chairman of the Audit and Compliance Committee with effect from June 21, 2022.
- (5) Mr. YICK, Wing Fat Simon (易永發) ceased to act as an Independent non-Executive Director, a member of the Audit and Compliance Committee and the chairman of the Remuneration and Nomination Committee with effect from June 14, 2022.

## Directors and Senior Management

**Executive Directors**

**LEI, Zili (雷自力) (Chairman and Chief Executive Officer)**, aged 52, was appointed as our non-Executive Director on June 8, 2021 and redesignated as an Executive Director on June 21, 2022. He was appointed as the Chairman of the Board on March 16, 2022 and the Chief Executive Officer on June 21, 2022. He served as a member of the Audit and Compliance Committee from June 8, 2021 to March 16, 2022. Mr. LEI is a member of the Global Strategy Council (**GSC**) of the Company. Mr. LEI has over 27 years of relevant experience in the automotive industry. As the Chairman of the Board, Mr. LEI is primarily responsible for chairing Board and shareholders' meetings and setting agendas, as well as facilitating communication between the Board and management. He serves as the chairman of AVIC Automotive Systems Holding Co., Ltd. (**AVIC Auto**) since May 2021, the chairman and of AVIC Hande (Beijing) Investment Holding Co., Ltd., a non wholly-owned subsidiary of AVIC Auto since May 2021, and the chairman of Henniges Automotive Holdings, Inc. since August 2020. He served as the chairman of Pacific Century Motors, Inc. (**PCM China**) and the director of Nexteer Automotive (Hong Kong) Holdings Limited (**Nexteer Hong Kong**) since November 2020. From December 2021 to November 2022 Mr. LEI served as the chairman of Guizhou Guihang Automotive Components Co., Ltd. (a company listed on the Shanghai Stock Exchange, stock code: 600523). From March 2013 to July 2020, he served as the executive director and general manager of AVIC Hubei Aviation Precision Machinery Technology Co., Ltd. From September 2000 to March 2013, he served successively as the deputy general manager, general manager of Hubei Aviation Precision Machinery Technology Co., Ltd. (a company listed on the Shenzhen Stock Exchange, Stock Code: 002013). From April 1995 to September 2000, he served successively as the planner, deputy manager and manager of the Planning Department of China Aviation Life-support Research Institute Jiali Branch. From July 1990 to April 1995, he served as the technician in the Petrochemical Department of China Aviation Life-support Research Institute. Mr. LEI graduated from Department of Mechanical Engineering of Zhengzhou University of Aeronautics in July 1990, obtained a master's degree in business administration from Zhongnan University of Economics and Law in October 2005. Mr. LEI is currently a senior economist awarded by Aviation Industry Corporation of China, Ltd. (**AVIC**).

**MILAVEC, Robin Zane**, aged 55, was appointed as our Executive Director on June 30, 2020. He was appointed as President of the Company on August 17, 2021 and was appointed as Chief Technology Officer and Chief Strategy Officer of the Company on July 1, 2019. In his combined responsibilities, Mr. MILAVEC will facilitate global alignment and teamwork, while spearheading the strategic direction of Nexteer and ensuring technology roadmap alignment with industry mega-trends to proactively capture growth opportunities. Mr. MILAVEC is a member of the GSC. He has over 33 years of relevant experience in the automotive industry, including positions in Product Engineering, Manufacturing Engineering, Operations and Quality. Mr. MILAVEC has been appointed as a director of Nexteer (China) Holding Co., Ltd., a subsidiary of the Group, with effect from August 17, 2021. At the Company, he served as Senior Vice President from July 2019 to August 2021, Vice President of Global Engineering from January 2018 to July 2019, Vice President of Global Current Product Engineering from June 2017 to January 2018, Executive Director of Global Product Engineering from August 2016 to June 2017, Director of Corporate Engineering and Global Programme Office from 2012 to 2016 and Chief Product Engineer for electric power steering from 2009 to 2012. At Delphi Saginaw Steering Systems, he served as Chief Product Engineer for driveline from 2005 to 2009, Chief Manufacturing Engineer for driveline from 2003 to 2005, and as Quality Manager for Saginaw plants 4 and 5 from 2000 to 2003. He served as an Engineering Supervisor at the Delphi Automotive Mexico Technical Centre in Juarez, Mexico from 1995 to 1997. Mr. MILAVEC began his career with General Motors in 1989 as a Product Engineer at the former Saginaw Steering Gear Division, and held several positions in engineering, quality and operations prior to his Mexico assignment in 1995. He obtained a bachelor's degree in mechanical engineering from New Mexico State University in Las Cruces, the US, in 1989 and a master's degree in mechanical engineering from the University of Michigan in Ann Arbor, the US, in 1992.

## Directors and Senior Management

### Non-Executive Directors

**WANG, Jian (王堅)**, aged 61, was appointed as our non-Executive Director and Chairman of the Board on June 3, 2019. Mr. WANG resigned as Chairman of the Board with effect from March 16, 2022. Mr. WANG has over 27 years of relevant experience in the automotive industry. From January 2018 to November 2021, Mr. WANG served as the chief economist of AVIC, our controlling shareholder. From August 2020 to May 2021, Mr. WANG served as the chairman of the board of AVIC Auto (a subsidiary of AVIC), our controlling shareholder. From May 2014 to September 2018, he was a director and the chairman of the board of AVIC Electromechanical Systems Co., Ltd. (Stock Code: 002013.SZ), a wholly-owned subsidiary of AVIC. From February 2010 to September 2018, he was a director, executive director and general manager of Aviation Electromechanical Systems Co., Ltd., a wholly-owned subsidiary of AVIC. From January 2013 to May 2014, he was the chairman of the board of Hubei Aviation Precision Machinery Technology Co., Ltd. (known as AVIC Electromechanical Systems Co., Ltd. since February 2014), a non wholly-owned subsidiary of AVIC. From February 2009 to February 2010, he was the deputy general manager of AVIC Electromechanical Systems Ltd., a wholly-owned subsidiary of AVIC. From March 2006 to May 2012, he was a director of China National Aero-Technology Import & Export Corporation, a wholly-owned subsidiary of AVIC, and AVIC International Holding Corporation, a non wholly-owned subsidiary of AVIC, respectively. From October 1998 to February 2010, he was the head of the research centre of the Jincheng Nanjing Engineering Institute of Aircraft Systems, a subsidiary of AVIC. From October 1998 to February 2010, he successively served as a director, deputy general manager, general manager, vice chairman of the board, as well as chairman of the board and general manager of Jincheng Group Co. Ltd., a wholly-owned subsidiary of AVIC. From August 1982 to September 1998, he successively acted as a technician, head of technical section, head of technical transformation section, head of planning department, head of production department, general manager and chief economist of motor business division, director of technical centre, director of quality control centre, deputy general manager and general manager of Jincheng Machinery Co., Ltd. (formerly as Jincheng Machinery Plant), a wholly-owned subsidiary of AVIC. Mr. WANG holds a postgraduate master's degree. He graduated in July 1982 from Nanjing Aeronautical Institute, China (now known as Nanjing University of Aeronautics and Astronautics, China) with a bachelor's degree majoring in machinery manufacturing engineering. He graduated in March 2003 from Beijing University of Aeronautics and Astronautics, China with a master's degree in economics and obtained a master's degree in business administration from Cheung Kong Graduate School of Business, China in December 2010.

**ZHANG, Wendong (張文冬)**, aged 46, was appointed as our non-Executive Director on November 13, 2020. Ms. ZHANG has served as the deputy general manager of Beijing E-Town International Investment & Development Co., Ltd. since July 2018. From November 2017 to November 2021, Ms. ZHANG served as the non-executive director, the member of audit committee, the member of compensation committee and the member of nominating and corporate governance committee of the board of UTStarcom Holdings Corp, a company listed on NASDAQ (ticker symbol: UTSI). Ms. ZHANG also held various positions in Beijing E-Town International Investment & Development Co., Ltd., including assistant to the general manager from June 2015 to July 2018, the director of asset management department from January 2014 to June 2015 and the deputy director of asset management department from December 2012 to January 2014. From October 2007 to December 2012, she served as the head of the corporate development department of Dongfang Cultural Asset Management Company; from July 2000 to September 2007, she served as the manager of the project department of Beijing Shengandi Investment Management Consulting Company. Ms. ZHANG is currently a senior economist. Ms. ZHANG graduated with a major in economics and obtained a bachelor's degree from Minzu University of China in May 2005. She obtained a master's degree in business administration (MBA) from University of Chinese Academy of Sciences, China in July 2016.

## Directors and Senior Management

**SHI, Shiming (石仕明)**, aged 43, was appointed as our non-Executive Director on June 21, 2022. Mr. SHI has over 20 years of experience in the finance industry. Mr. SHI is currently an executive director of Nexteer Automotive (Hong Kong) Holdings Limited, the immediate controlling shareholder of the Company. From July 2002 to February 2003, Mr. SHI worked in the finance department of Jiangxi Hongdu Aviation Industry Group. From February 2003 to June 2020, Mr. SHI worked in the finance department of AviChina Industry & Technology Company Limited (**AviChina**), a company listed on the Stock Exchange, and served successively in the roles of assistant to the chief manager, deputy manager and chief manager of finance. He was also a supervisor of AviChina from June 2018 to December 2020. Mr. SHI has served as the chief financial officer of AVIC Automotive Systems Holding Co., Ltd., an indirect controlling shareholder of the Company, since July 2020. Mr. SHI graduated from the department of economics and law of Zhongnan University of Economics and Law, the PRC in 2002, majoring in finance taxation, and obtained his master's degree in accounting from Renmin University of China, the PRC in 2009.

**Independent Non-Executive Directors**

**LIU, Jianjun (劉健君)**, aged 54, was appointed as our Independent non-Executive Director on June 15, 2013. Mr. LIU was in the legal department of China Ocean Shipping (Group) Company container lines (中國遠洋運輸集團總公司 集裝箱運輸) from July 1993 to March 1999, a partner at Zhong Sheng Law Firm, Beijing (北京中盛律師事務所), from April 2001 to October 2006, a senior associate in Zhong Lun Law Firm, Beijing (北京中倫律師事務所) from November 2006 to May 2007, and has been a partner at Zhonglun W&D Law Firm, Beijing (北京中倫文德律師事務所), since June 2007. Mr. LIU started practicing as lawyer in China in August 2001. He obtained a master's degree in law from Peking University, China, in July 1998, and a law degree from Washington University in St. Louis, the USA, in May 2004.

**Dr. WANG, Bin (王斌)**, aged 57, was appointed as our Independent non-Executive Director on June 21, 2022. Dr. WANG is a professor of finance at the business school of Beijing Technology and Business University, as well as a member of its university-level academic committee. He is currently an independent director of China Tourism Group Duty Free Corporation Limited (中國旅遊集團中免股份有限公司) (listed on the Shanghai Stock Exchange), UBS Securities Co., Ltd (瑞銀證券有限責任公司) and China Tea Co., Ltd (中國茶葉股份有限公司), respectively. Dr. WANG graduated from Beijing Technology and Business University with a bachelor's degree in accounting in July 1987 and a master's degree in accounting in December 1989, and from the Chinese Academy of Fiscal Science (Ministry of Finance of China) with a doctorate in accounting in July 2001. Dr. WANG is the author of over 50 academic papers in top domestic and foreign academic publications and journals. He is one of the directors of Accounting Society of China, as well as the vice-chairman of its management accounting research committee since 2007. Dr. WANG has received various accolades in relation to his work as a top academic in China.

**Mr. YUE, Yun (岳雲)**, aged 52, was appointed as our Independent non-Executive Director on June 21, 2022. Mr. YUE is a practicing lawyer, senior partner and deputy director of Beijing Jundu Law Firm with more than 18 years of experience in the legal field. Mr. YUE, Yun was a representative of the 9th, 10th and 11th Shanghai Lawyers' Congress, a member of the Shanghai Lawyers Association Mergers and Acquisitions Committee, and a member of the Shanghai Lawyers Association Disciplinary Committee. He previously served as an independent director of AECC Aviation Power Co., Ltd. (中國航發動力股份有限公司) from January 2015 to March 2021. Mr. YUE graduated from the department of social sciences of Hefei University in July 1992 and further obtained his master's degree in civil and commercial law from East China University of Political Science and Law in July 2005.

## Directors and Senior Management

**SENIOR MANAGEMENT**

Our senior management is responsible for the day-to-day management of our business. The table below shows certain information in respect of the senior management of our Company (collectively, the **Senior Management**) during the year ended December 31, 2022 and as at the date of this annual report:

Name	Age	Position/Title
LEI, Zili (雷自力) <sup>(1)</sup>	52	Chief Executive Officer
MILAVEC, Robin Zane <sup>(1)</sup>	55	President, Chief Technology Officer and Chief Strategy Officer
BOYER, Hervé Paul	51	Senior Vice President and Global Chief Operating Officer
BIERLEIN, Michael John	46	Senior Vice President and Chief Financial Officer
BENSON, OT	48	Vice President and EMEASA Division President
LI, Jun (李軍)	50	Vice President, APAC Division President and eDrive Product Line
DRALLE, Jill Annette	51	Vice President, Chief Operating Officer – USA
HARRIS, Steven Robert	56	Vice President, Global Engineering
ZICHELLA, Giuseppe <sup>(2)</sup>	54	Vice President, Global Sales
PASTOR, Ricardo Antonio	57	Vice President, Global Quality and Programme Launch and Global Manufacturing Operations
SPENCER, Jr., Robert William	49	Vice President and General Counsel
ZIPARO, Peter Michael <sup>(3)</sup>	53	Vice President and General Counsel
BYERS, David Michael	57	Vice President, Global Sales

Notes:

- (1) Individual is an Executive Director – Please refer to the section headed 'Directors and Senior Management – Directors' earlier in this report for biographical details.
- (2) Mr. ZICHELLA, Giuseppe ceased to act as Vice President, Global Sales with effect from March 6, 2023.
- (3) Mr. ZIPARO, Peter Michael ceased to act as Vice President and General Counsel with effect from October 14, 2022.

**BOYER, Hervé Paul**, aged 51, was appointed as our Senior Vice President, Global Chief Operating Officer and North America Division President in August 2021. He leads efforts to enhance Nexteer's operational efficiencies and profitability – including Nexteer's day-to-day value chain management and profit & loss performance across all divisions. He is also a member of the GSC. Mr. BOYER has over 23 years of relevant experience in the automotive industry. From March 2016 to August 2021, Mr. Boyer held the position of Vice President, Divisional President – EMEASA Division. Prior to Nexteer, from May 2015 to February 2016, Mr. BOYER held the position of executive director of the NBHX Electronics group where he had the responsibility to run the Interior Trims business. Mr. BOYER spent several years within the Faurecia group where he served as president of North America Operations from June 2012 to July 2014 for the Interior Systems business group. From January 2009 to June 2012, Mr. BOYER was vice president of the South Europe perimeter of Faurecia Interior Systems and previously served as vice president for French, US and Japanese Divisions, from May 2008 to December 2008. Mr. BOYER has also served as director for the Renault-Nissan Division from January 2006 to May 2008. From 2001 to 2005, Mr. BOYER held several sales and marketing positions at Faurecia Interior Systems and served as programme manager from September 1994 when he joined Sommer Allibert Industrie which was acquired by Faurecia group in late 2000. Mr. BOYER earned a degree in manufacturing engineering from L'École Centrale de Nantes, France, in 1994 and attended the Advance Management Programme of Harvard Business School, the USA, in 2014.

## Directors and Senior Management

**BIERLEIN, Michael John**, aged 46, was appointed as our Senior Vice President and Chief Financial Officer in September 2021. He is responsible for overseeing investor relations, treasury, capital funding and structure, mergers and acquisitions support, accounting and financial reporting, and financial planning and analysis. He is also a member of the GSC. Mr. BIERLEIN has 24 years of relevant experience in the automotive industry. From August 2020 to August 2021, Mr. BIERLEIN served as Nexteer's North America Chief Financial Officer and Global Engineering Finance after serving as Executive Director, Strategic Financial Planning from March 2015 to August 2020. Prior to joining Nexteer, Mr. BIERLEIN spent 17 years with Delphi Corporation in a variety of financial leadership roles both at a divisional and corporate level ranging from Financial Director and Controller to Senior Manager – Strategic Planning, Labour Negotiations, Financial Planning and Analysis and Plant Controller. Mr. BIERLEIN earned a degree in Finance in 1998 and a Masters of Business Administration in 2003 from Michigan State University, the USA.

**BENSON, OT**, aged 48, was appointed as our Vice President, EMEASA Division President and is responsible for the EMEASA Division, gaining commitments from the business lines and leveraging corporate functions to meet the business plan of the division. Mr. BENSON is a member of the GSC. He offers nearly 15 years of service in the automotive industry, primarily within global supply chain management, in addition to 8 years of active duty service in the United States Air Force. Mr. BENSON most recently served as Vice President, Global Sales and Marketing since June 2019 and Vice President, Global Supply Management (**GSM**) since June 2018 and Director of North America GSM since 2013. In these roles, Mr. BENSON was responsible for managing supply chain operations, developing supplier relationships and delivering benchmark material cost, quality and launch performance to our North America plants in the US and Mexico. In 2017, Mr. BENSON rejoined Nexteer after serving two years as vice president of Global Procurement at Nidec Motor Corporation. Mr. BENSON began his career with Delphi Steering's GSM team in 2005, where he held positions including China business line purchasing manager, Suzhou Steering Purchasing Manager and Enterprise Commodity Manager. Mr. BENSON holds a bachelor of Science in marketing and Asian studies from Utah State, the USA; a Master of Business Administration in international management from East Carolina University, the USA; and a Master of Arts in Chinese linguistics from the University of Hawaii at Manoa, the USA.

**LI, Jun (李軍)**, aged 50, was appointed as our Vice President, APAC Division President and eDrive Product Line on January 1, 2022. In this role, he is responsible for leading and achieving the strategic objectives of the APAC Division, as well as leading global cross-functional collaboration to define and execute this product line's technology, portfolio strategy, customer strategy and industrialisation plans. He is a member of the GSC. Mr. LI offers over 20 years of relevant experience in the automotive industry. Prior to his current role, Mr. LI was Vice President and APAC Division President from November 2017 to January 2020 and he was responsible for eDrive product line from January 2020 to December 2021. From October 2016 to November 2017, Mr. LI was Executive Director and Chief Operating Officer – Asia Pacific Division with the same responsibility. Before that, he served as Asia Pacific Steering Business Director from February 2015 to October 2016 and was responsible for developing the overall business plan and competitiveness. From May 2012 to January 2015, Mr. LI held the position as General Manager to oversee the operations of Nexteer Automotive (Suzhou) Co., Ltd. (**Nexteer Suzhou**). From 2010 to May 2012, Mr. LI served as Plant Manager and was responsible for the overall operational management of Nexteer Suzhou Plant 53. During 2008 and 2010, he took the role as Programme Manager of China's first EPS Programme at Saginaw Steering (Suzhou) Co., Ltd. From 2004 to 2007, Mr. LI served as Programme Launch Manager and Engineering Manager at Delphi Automotive in Shanghai. Prior to joining Nexteer and Delphi Automotive, he held various supervisory positions in manufacturing, project management and engineering at Dongfeng Motor Group for 6 years, and 5 years at China Aerospace Science and Technology Corporation. He obtained a Diploma in Science and Technology in mechanical engineering from Huazhong University of Science & Technology, China in 1991, and a master's degree in business administration from the University of Electronic Science & Technology of China, China, in 2004.

## Directors and Senior Management

**DRALLE, Jill Annette**, aged 51, was appointed as our Vice President, Chief Operating Officer, USA on March 17, 2021. She is responsible for the entire USA business, gaining commitments from the business lines and leveraging corporate functions to meet the business plan of the division. Ms. DRALLE brings over 26 years of relevant automotive experience. Prior to her current role, she was Chief Operating Officer of US Operations with a dual role as General Manager of the Columns-HPS Business Unit in Saginaw from May 2019 to March 2021. Ms. DRALLE has held many essential positions at Nexteer since 2008. She was Executive Director of Operational Excellence & Strategy for North America from 2014 to 2018, Plant Manager of Driveline from 2012 to 2014, Plant Operations Manager from 2011 to 2012, and Lean Change Agent for multiple plants from 2008 to 2011. Before Ms. DRALLE joined Nexteer she worked at Delphi Automotive Systems in varying key roles in industrial and manufacturing engineering, quality and operations management. Ms. DRALLE began her automotive career in 1994 with General Motors at the former Saginaw Steering Gear Division and held numerous assignments of increasing responsibility in manufacturing engineering. Ms. DRALLE obtained a bachelor's degree in engineering from Saginaw Valley State University, the USA, in 1993 and was honoured as a distinguished alumni in 2019.

**HARRIS, Steven Robert**, aged 56, was appointed as our Vice President, Global Engineering in July 2021. He is responsible for global product and manufacturing engineering activities, implementing the product portfolio and production support. He is also a member of the GSC. Mr. HARRIS has over 33 years of relevant automotive experience. Over his career at Nexteer, which began in 1989 as GM/Delphi Steering Systems, he has held multiple, progressive leadership positions across the hydraulic power steering product line (HPS), and electric power steering (EPS) product line. From 2012 to 2016, Mr. HARRIS took an international assignment in Nexteer APAC Suzhou, China starting as Senior Manager EPS Product Engineering, followed by Chief Product Engineer, Steering Systems, before being appointed APAC Engineering Director. In 2016, Mr. HARRIS returned to the US as Executive Director for EPS Product Engineering. Mr. HARRIS earned a degree in Mechanical Technology from Purdue University, the USA, in 1988 and an MBA from the University of Michigan-Flint, the USA, in 1996.

**PASTOR, Ricardo Antonio**, aged 57, was appointed as our Vice President, Global Quality and Programme Launch on November 16, 2017. He is responsible for all facets of the Global Quality function including strategic planning, execution, measurement and administration of quality systems and controls. He is also in charge of Customer Programme Implementation (**CPI**) where he leads the optimisation of the CPI process and oversees programme launches to ensure successful performance. Mr. PASTOR is a member of the GSC. Mr. PASTOR brings over 33 years of experience in the automotive industry. Mr. PASTOR served as Executive Director of Global Quality at Nexteer since June 2015. Prior to leading the Global Quality function, he was Quality Director for the International and China Divisions from 2010 to 2015. Mr. PASTOR was senior manager in manufacturing planning in 2009, Director of footprint expansion for Asia Pacific from 2006 to 2009 and Chief Engineer for Europe from 2004 to 2006 at Delphi Automotive. Mr. PASTOR held many other leadership positions in engineering quality and programme launch prior to 2006. Over his career, Mr. PASTOR had nine years of expatriate assignments between Europe and China. Mr. PASTOR began his automotive career with General Motors in 1984 at the former Saginaw Steering Gear Division. He obtained a Bachelor of Science degree in electrical engineering with minors in mathematics and chemistry, summa cum laude, from Saginaw Valley State College, the USA, in 1987 and a Master of Science degree in electrical engineering from Oakland University, the USA, in 1990.



## Directors and Senior Management

**SPENCER, Jr., Robert William**, aged 49, was appointed our Vice President and General Counsel, in January 2023. He is responsible for all global legal and compliance matters for the organisation and acts as the Company's primary legal advisor in managing major transactions. He is also responsible for overseeing Nexteer's global compliance and sustainability functions. He is a member of Nexteer's GSC. Mr. SPENCER has over 20 years of experience in managing global legal and compliance functions across the automotive, financial and technology industries. Prior to Nexteer, Mr. SPENCER was General Counsel at Henniges Automotive from 2019 to 2023. From 2007 to 2019, he served as Senior Director, Senior Counsel and Assistant Secretary at Dana Incorporated as well as was General Counsel of its Commercial Vehicle and Electrification division. From 2005 to 2007, he served as Vice President, Finance and Securities Counsel and Assistant Secretary, at Comerica Incorporated, and from 2003 to 2004, he was Director and Associate Counsel at Bread Financial (formerly Alliance Data Systems Corporation). Mr. SPENCER's experience also includes posts as a corporate associate with Benesch Friedlander Coplan & Aronoff, LLP (2000-2003) and Stark & Knoll Co., L.P.A., (1998-2000). Mr. SPENCER earned a Bachelor of Science in Business Administration from the Fisher College of Business at The Ohio State University, USA, in 1995, a Juris Doctor from the University of Illinois, USA, in 1998, and a Master of Business Administration from the Ross School of Business at the University of Michigan, USA, in 2017.

**BYERS, David Michael**, aged 57, was appointed as our Vice President, Global Sales on March 7, 2023. He is responsible for all commercial efforts for the organisation around the globe – leading cross-functional teams to achieve strategic sales goals and playing an integral role in the future profitable growth of the Company. He is a member of the GSC. Mr. BYERS has over 33 years of automotive engineering experience. In his most recent role, he served as Vice President, Electric Power Steering Product Line from March 17, 2021 to March 7, 2023, responsible for developing the overall global EPS product line business plan, strategy and competitiveness. He previously served as Product Line Executive Director – Global EPS from December 2019 to March 2021. He has been an impactful leader at Nexteer, Delphi and GM serving in different roles such as Product Line Executive Director for Rack EPS, Chief Manufacturing Engineer and other leadership roles within engineering. Overall, Mr. BYERS has 15 years of product engineering experience, 15 years of manufacturing engineering/operations experience and 3 years of Product Line Management experience. He has been responsible for 11 US patents and 4 defensive publications throughout his career. Mr. BYERS began his automotive career with General Motors in 1987 at the former Saginaw Steering Gear Division. He obtained a Bachelor of Science degree in mechanical engineering from Clarkson University, the USA, in 1987 and a Master of Business Administration from the University of Michigan – Flint, the USA, in 1993.

### RELATIONSHIPS BETWEEN DIRECTORS AND SENIOR MANAGEMENT

None of the Directors or members of the Senior Management are related to any other Director or member of the Senior Management.

# Directors' Report

The Directors are pleased to present their report together with the Consolidated Financial Statements.

## CORPORATE INFORMATION AND GLOBAL OFFERING

The Company was incorporated in the Cayman Islands on August 21, 2012 as an exempted company with limited liability under the Companies Laws (as amended), of the Cayman Islands (the **Companies Law**). The Company's shares (the Shares) were listed on the Hong Kong Stock Exchange on October 7, 2013.

## PRINCIPAL ACTIVITIES

The Group develops, manufactures and supplies advanced steering and driveline systems to OEMs throughout the world.

## BUSINESS REVIEW

A review of the business of the Group for the year ended December 31, 2022 and a discussion on the Group's future prospects are provided in the Management Discussion and Analysis on pages 28 through 39 and in the CEO Statement on pages 6 through 7. An analysis of the Group's performance during the year using financial key performance indicators is provided within the Financial Highlights on page 27. In addition, discussions on the Group's key policies, relationships with its key stakeholders and compliance with relevant laws and regulations which have a significant impact on the Group are contained in the Corporate Governance Report on pages 66 through 81 and in this Directors' Report.

## KEY RISK AND UNCERTAINTIES

The Group's financial condition, results of operations, businesses and prospects may be affected by a number of risks and uncertainties. The following are the key risks and uncertainties identified by the Group. There may be other risks and uncertainties in addition to those shown below which are not known to the Group or which may not be material now but could turn out to be material in the future.

### Operational Risk

Operational risk is the risk of loss resulting from inadequate or failed internal processes, people and systems or from external events. Responsibility for managing operational risks rests with every function at divisional and department levels. The Group recognises that operational risks cannot be eliminated completely and that it may not always be cost-effective to do so.

Key functions in the Group are guided by their standard operating procedures, limits of authority and reporting framework. Functions such as, but not limited to, Internal Audit and Internal Control have the responsibility for providing assurance on the internal control framework. Key operational risk exposures are communicated to Senior Management as early as possible so that appropriate risk response can be taken.

### Financial Risk

In the course of business activities, the Group is exposed to a variety of financial risks, including market, liquidity and credit risks. The currency environment, interest rate cycles and mark-to-market value of investment securities may pose significant risks to the Group's financial condition, results of operations and businesses. The financial risk management objectives and policies of the Group can be found in note 3 to the Consolidated Financial Statements.

**Business Risks***Cyclical industry and a decline in production levels*

Our sales are driven by the number of vehicles produced by the automotive manufacturers which is ultimately dependent on consumer demand. The automotive industry is cyclical and sensitive to general economic conditions, including the global credit markets, interest rates, consumer credit, and consumer spending and preferences. Automotive sales and production can also be affected by the age of the vehicle fleet and related scrappage rates, labour relation issues, fuel prices, regulatory requirements, government initiatives, trade agreements, restructuring actions of our customers and suppliers, increased competition and other factors.

*Concentration of sales and terms and conditions of the agreement with GM*

The supply of products to GM are governed by various agreements and standard terms and conditions applicable to each programme. Certain limited programmes also remain subject to a supply agreement, dated November 30, 2010, pursuant to which we have agreed to continue to manufacture and deliver certain products to GM. For both the years ended December 31, 2021 and 2022, our largest customer, GM, accounted for approximately 32% our consolidated revenues. A significant decrease in business from GM could materially and adversely impact our business, results of operations and financial condition.

*Loss of business or lack of commercial success*

Purchase orders generally provide for the supply of a customer's annual requirements for a particular vehicle model, and in some cases, for the supply of a customer's requirements for the life of a particular vehicle model, rather than for the purchase of a specific quantity of products. Lack of commercial success could reduce our revenues or margins and thereby adversely affect our financial condition, operating results and cash flows.

*Inability to achieve product cost reductions*

During negotiations with the customers, customers tend to demand price reduction over the life of a vehicle model. We also bear significant responsibility on the product design, development and manufacturing engineering. Our financial performance is largely dependent on our ability to achieve product cost reductions through product design enhancement and manufacturing efficiencies. If we fail to achieve cost reductions, it would adversely affect our financial condition, operating results and cash flows.

*Increase in costs and restrictions on availability of raw materials and component supply*

The cost of raw materials accounted for approximately 66.7% and 62.6% of our consolidated revenues for the years ended December 31, 2022 and 2021, respectively. Raw material, energy, and commodity costs can be volatile. If the costs of raw materials, energy, commodities, and product components increase or the availability thereof is restricted, it could adversely affect our financial condition, operating results and cash flows.

The COVID-19 pandemic and government actions and measures taken to prevent its spread continue to have an impact on our operations. Government-imposed restrictions on businesses, operations and travel, and the related economic uncertainty, have impacted demand for our customers' vehicles in some global markets. The extent of COVID-19's impact on our future operations, liquidity and the demand for our products will depend upon, among other things, the duration and severity of the outbreak or subsequent outbreaks, related government responses, such as required physical distancing or restrictions on business operations and travel, the pace of recovery of economic activity and the impact to our customers, the effectiveness of available vaccines and any potential supply disruptions, all of which are uncertain and difficult to predict in light of the rapidly evolving landscape.

As a result of the COVID-19 pandemic and other factors, the automotive industry and the Group are currently experiencing global shortages in the supply of various sub-components and raw materials, including semi-conductors. These supply shortages have impacted multiple customers and suppliers resulting in reductions or suspension of vehicle production. We expect these supply shortages will have a short-term impact on our business, however, there can be no assurance that these supply shortages will not continue longer than expected or expand to other materials used by the Group, its suppliers or its customers and may have a significant impact on our future operations and liquidity.

## Directors' Report

### *Conflict in Ukraine*

In February 2022, Russian military forces entered Ukraine resulting in a military conflict between the two countries (the **Ukraine Conflict**). In response, many countries, including the U.S., the United Kingdom and the European Union, have imposed unprecedented sanctions and controls on certain Russian citizens, organisations and goods. The Ukraine Conflict is likely to impact the Group and the global automotive industry, including the availability and pricing of raw materials, energy, commodities, and product components, the ability of OEMs to meet production forecasts and/or impact the global consumer demand for vehicles. Any of these effects could adversely affect our financial condition, operating results and cash flows.

### *Substantial international operations*

As a result of our global presence, a significant portion of our revenues and expenses are denominated in currencies other than the US dollar. International operations are subject to certain risks inherent in doing business abroad, including exposure to local economic conditions; political, economic, and civil instability and uncertainty; labour unrest; an outbreak of a contagious disease, an epidemic or pandemic or other public health crises, which may cause us or our suppliers and/or customers to temporarily suspend operations in the affected city or country; currency exchange rate fluctuations and the ability to hedge currencies; and increases in working capital requirements related to long supply chains.

### *Highly competitive industry and efforts by our competitors to gain market share*

We operate in a highly competitive industry and our competitors are seeking to expand market share with new and existing customers. Our competitors' efforts to grow market share could create downward pressure on our product pricing and margins. If we are unable to differentiate our products or maintain a low-cost footprint, we may lose market share or be forced to reduce prices, thereby lowering our margins. Any such occurrence could adversely affect our financial condition, operating results and cash flows.

### *Our existing indebtedness and the inability to access capital markets*

As at December 31, 2022, we had approximately US\$49.8 million of outstanding indebtedness, as well as US\$365.6 million available but not yet drawn under our credit facilities. The debt instruments governing our indebtedness contain covenants that may restrict our business activities or our ability to execute our strategic objectives, and our failure to comply with these covenants could result in a default under our indebtedness. Additionally, any downgrade in the ratings that rating agencies assign to us and our debt may ultimately impact our access to capital markets. Our inability to generate sufficient cash flow to satisfy our debt and lease obligations, to refinance our debt obligations or to access capital markets on commercially reasonable terms could adversely affect our financial condition, operating results and cash flows.

### *Impairment charges relating to our long-lived assets*

We regularly monitor our long-lived assets for impairment indicators. Our consolidated balance sheet as at December 31, 2022 reflects a carrying amount of capitalised engineering and product development costs of US\$724.8 million, a carrying amount of property, plant and equipment of US\$971.2 million and a carrying amount of right-of-use assets of US\$62.1 million. In the event that we determine that our long-lived assets are impaired, we may be required to record a significant charge to earnings that could adversely affect our financial condition or operating results as set out in notes 2.8, 6 and 8 to the Consolidated Financial Statements.

### *Our intellectual property portfolio*

We own intellectual property, including patents, trademarks, copyrights and trade secrets. In some cases, we enter into licensing agreements with respect to intellectual property. In addition, we rely on unpatented proprietary technology. These assets play an important role in maintaining our competitive position. We may assert claims against third parties that we believe are infringing on our intellectual property rights. These claims, regardless of their merit or resolution, are typically costly to pursue. Risks related to the protection of our intellectual property could have a material adverse effect on our business, results of operations and financial condition.

## Directors' Report

*Significant product liability lawsuit or warranty claim*

In the event that our products fail to perform as expected, whether alleged or due to an actual fault, we may be subject to product liability lawsuits and other claims or we may be required by our customers or regulators to participate in a recall or other corrective action involving such products. We have also entered into agreements with certain customers where these customers may pursue claims against us for all or a portion of the amounts sought in connection with product liability and warranty claims. We carry insurance for certain product liability claims, but such coverage may be limited. These types of claims could adversely affect our financial condition, operating results and cash flows. As at December 31, 2022, our consolidated balance sheet includes provisions totalling US\$58.7 million related to estimated warranty and product liability obligations.

*Information technology*

A failure of our information technology (**IT**) infrastructure could adversely impact our business and operations. We rely on the capacity, reliability and security of our IT systems and infrastructure. IT systems are vulnerable to disruptions, including those resulting from natural disasters, cyber-attacks or failures in third-party provided services. Disruptions and attacks on our IT systems pose a risk to the security of our systems and our ability to protect our networks and the confidentiality, availability and integrity of our third-party data. As a result, such attacks or disruptions could potentially lead to the inappropriate disclosure of confidential information, including our intellectual property, improper use of our systems and networks, manipulation and destruction of data, production downtimes and both internal and external supply shortages. This could cause significant damage to our reputation, affect our relationships with our customers and suppliers, lead to claims against the Group and ultimately, adversely affect our business.

*Environmental laws and regulations*

Our global facilities are subject to numerous laws and regulations designed to protect the environment. If we fail to comply with present and future environmental laws and regulations, we could be subject to future liabilities, which could adversely affect our financial condition, operating results and cash flows.

*Global climate change and related emphasis on ESG matters by various stakeholders could negatively affect our business*

Increased public awareness and concern regarding global climate change may result in more regional, federal, national and/or international requirements to reduce or mitigate the effects of greenhouse gas (**GHG**) emissions. There continues to be various and complex climate legislation, which creates economic and regulatory uncertainty. Such regulatory uncertainty extends to future incentives for energy efficient vehicles and costs of compliance, which may impact the demand and supply for our products and our results of operations.

There is a growing consensus that GHG emissions are linked to global climate changes. Climate changes, such as acute and chronic conditions, create potential financial risk to our business. For example, the demand for our products and services may be affected by unseasonable weather conditions. Climate changes could also disrupt our operations by impacting the availability, cost of materials and logistics needed for manufacturing and could increase insurance and other operating costs. These factors may impact our decisions to construct new facilities or maintain existing facilities in areas most prone to physical climate risks. Besides physical climate risks, the Group could also be subject to transition climate risks in the form of rising cost of carbon, market and technology risk exposures during transition to a low-carbon economy.

Further, stakeholder expectations, such as those from customers, investors, and employees in ESG subjects have been rapidly evolving and increasing. For example, certain customers are beginning to require that the Group provide information on its plans relating to certain environmental sustainability-related matters, such as GHG emissions and renewable energy. The enhanced stakeholder focus on ESG issues relating to the Group requires the continuous monitoring of various and evolving standards and the associated reporting requirements. A failure to adequately meet stakeholder expectations may result in the loss of business, diluted market valuation, an inability to attract customers or an inability to attract and retain top talent.

## Directors' Report

### *Income tax legislation and regulatory environment*

The Group continues to monitor the developments by the office of Organisation for Economic Cooperation and Development (**OECD**) on its continued efforts toward its Base Erosion and Profit Shifting initiative by focusing on two pillars which could affect the Group's effective tax rate. Pillar One addresses tax presence in a country and profit allocation between countries. Pillar Two, also known as Global-Anti Base Erosion Rules (**GLoBE**), is designed to ensure large multinational enterprises (**MNEs**) pay a 15% minimum tax. The expected timing of implementation for Pillar Two is January 1, 2024 and the expected timing of Pillar One is uncertain. However, the shape and implementation of this reform may adversely impact the Group's consolidated effective tax rate.

The Group continues to monitor proposed changes to US tax laws and regulations that have been proposed by US Congress which could affect the Group's effective tax rate. Since the likelihood of these or other changes to US tax law being enacted are unclear, the Group is currently unable to determine the impact these changes may have to its tax expense, including if the proposed changes may materially impact the Group's earnings and cash flows.

The preferential tax treatment that our People's Republic of China (**PRC**) subsidiaries enjoy may be changed or discontinued, which may adversely affect our business, result of operations and financial condition. Nexteer Automotive Suzhou Co., Ltd., Nexteer Lingyun Driveline (Zhuzhou) Co., Ltd. and Nexteer Lingyun Driveline (Wuhu) Co., Ltd. are expected to maintain high-tech certificates, which are scheduled to expire in 2023, 2024 and 2024, respectively. In order to maintain eligibility for the preferential income tax rate of 15%, the subsidiaries are obligated to meet on-going requirements. We cannot assure that we will maintain this preferential tax rate for future periods. Nexteer Automotive Systems (Liuzhou) Co., Ltd. received a special 'Go West' preferential 15% income tax rate through 2030.

Any of these changes could impact the Group, our shareholders, and affiliates, and could adversely affect the Group by changing our effective tax rate and limiting the Group's ability to utilise cash in a tax efficient manner.

### **Strategic Objectives Risk**

Our financial performance depends, in part, on our ability to successfully execute our strategic objectives. Our strategy is to deliver superior long-term shareholder value by growing our business through investments and improving our competitive position, while maintaining a strong balance sheet and returning cash to our shareholders. Our failure to execute our strategic objectives could adversely affect our financial condition, operating results and cash flows.

### **Joint Venture Partners Risk**

Some of the businesses of the Group are conducted through non wholly-owned subsidiaries, associates, joint ventures and joint operations in which the Group shares control with the joint venture partners. There is no assurance that any of these joint venture partners will continue their relationships with the Group in the future or whether their goals or strategies are in line with the Group. Such joint venture partners may have business interests or goals which are different from the Group. They may experience financial and other difficulties or may be unable to fulfill their obligations under the joint ventures which may affect the Group's businesses and operations.

## FINAL DIVIDEND

The Board recommends the payment of a final dividend of approximately US\$11.8 million, or US\$0.0047 per Share, which represents approximately 20% of the Group's net profit attributable to equity holders for the year ended December 31, 2022, subject to the approval of the shareholders at the forthcoming annual general meeting of the Company (the **AGM**).

The payment shall be made in US dollars, except that payment to shareholders whose names appear on the register of members in Hong Kong shall be paid in Hong Kong dollars. The relevant exchange rate shall be the opening buying rate of Hong Kong dollars to US dollars as announced by the Hong Kong Association of Banks ([www.hkab.org.hk](http://www.hkab.org.hk)) on the day of the approval of the distribution at the AGM.

## DISTRIBUTABLE RESERVES

As at December 31, 2022, the Company's reserves available for distribution, calculated in accordance with the provisions of the Companies Law, amounted to approximately US\$569.7 million (as at December 31, 2021: US\$479.6 million).

## SHARE CAPITAL

Details of movements in the share capital of the Company during the year ended December 31, 2022 are set out in note 33 to the Consolidated Financial Statements.

## PRE-EMPTIVE RIGHTS

There are no provisions for pre-emptive rights under the Amended and Restated Memorandum and Articles of Association of the Company (the **Articles of Association**) or the laws of the Cayman Islands that would oblige the Company to offer new Shares on a pro-rata basis to existing shareholders.

## EQUITY-LINKED AGREEMENTS

Details of the share options granted in prior years and current year are set out in note 24 of the Consolidated Financial Statements and 'Share Option Scheme' section contained in this Directors' Report. For the share options granted during the year ended December 31, 2022, no Shares were issued during the year. Except as disclosed above, the Company has not entered into any equity-linked agreements for the year ended December 31, 2022.

## ESG SUMMARY

The Group is committed to conducting our business in an environmentally sound manner and has adopted the ESG Reporting Guide as required by the Listing Rules. The Board will continue to monitor such policies to ensure the Group remains compliant with the relevant laws and regulations that have a significant impact on the Group in relation to the environment, employment, labour and operation. In addition to carrying out the corporate-wide programmes the Group has initiated, all of our employees are required to be familiar with environmental laws and regulations relevant to their employment responsibilities and to comply with them. In accordance with the ESG Reporting Guide, as set out in Appendix 27 to the Listing Rules, details of the above information will be set out in our ESG report (annual Sustainability Report), which is to be published and available on the Company's website (<https://www.nexteer.com/sustainability/>), as well as the Hong Kong Stock Exchange's website (<https://www.hkexnews.hk/>) at the same time as this Annual Report.

If a printed copy of the ESG report is needed, please make your written request to the Company's share registrar – contact information provided on page 78. We appreciate your kind consideration of environmental footprint and encourage your assessing the ESG report via websites provided above.

## Directors' Report

### CHARITABLE DONATIONS

During 2022, the charitable contributions and other donations made globally by us amounted to US\$0.1 million.

In 2022, our employees volunteered more than 19,500 hours of time supporting local charitable efforts and creating brand awareness through the Group's philanthropic activities.

### DIRECTORS

The Directors in office during the year ended December 31, 2022 and as at the date of this annual report were as follows:

#### Executive Directors

LEI, Zili (雷自力) (*Chairman*)

MILAVEC, Robin Zane

ZHAO, Guibin (趙桂斌) (ceased to act with effect from June 14, 2022)

FAN, Yi (樊毅) (ceased to act with effect from June 21, 2022)

#### Non-Executive Directors

WANG, Jian (王堅)

ZHANG, Wendong (張文冬)

SHI, Shiming (石仕明) (appointed with effect from June 21, 2022)

LEI, Zili (雷自力) (appointed as Chairman with effect from March 16, 2022 and re-designated from non-Executive Director to Executive Director with effect from June 21, 2022)

#### Independent Non-Executive Directors

LIU, Jianjun (劉健君)

WANG, Bin (王斌) (appointed with effect from June 21, 2022)

YUE, Yun (岳雲) (appointed with effect from June 21, 2022)

WEI, Kevin Cheng (蔚成) (ceased to act with effect from June 21, 2022)

YICK, Wing Fat Simon (易永發) (ceased to act with effect from June 14, 2022)

Further details of the Directors are set forth in the section headed 'Directors and Senior Management' in this annual report.

Pursuant to Article 16.2 of the Articles of Association, any Director appointed by the Board, either to fill a casual vacancy or as an addition to the existing Directors, shall hold office only until the next following AGM of the Company and shall then be eligible for election at that meeting.

Pursuant to Article 16.18 of the Articles of Association, at every AGM one-third of the Directors for the time being shall retire from office by rotation provided that every Director shall be subject to retirement by rotation at least once every three years.

Details of the Directors to be re-elected at the AGM will be set out in the circular to the shareholders of the Company prior to its upcoming AGM.



## CHANGES TO INFORMATION IN RESPECT OF DIRECTORS

The director's fee of each of the non-Executive Directors (namely Mr. WANG, Jian, Ms. ZHANG, Wendong and Mr. SHI, Shiming) has been adjusted from US\$42,000 per annum to US\$50,700 per annum with effect from January 1, 2023.

Mr. LIU, Jianjun's director's fee has been adjusted from US\$68,250 per annum to US\$82,400 per annum with effect from January 1, 2023.

Dr. WANG Bin's director's fee has been adjusted from US\$68,250 per annum to US\$82,400 per annum with effect from January 1, 2023.

Mr. YUE, Yun's director's fee has been adjusted from US\$55,650 per annum to US\$67,200 per annum with effect from January 1, 2023.

Except as disclosed above and in the section headed 'Directors and Senior Management' in this annual report, there was no change to any of the information required to be disclosed in relation to any Director pursuant to paragraphs (a) to (e) and (g) of Rule 13.51(2) of the Listing Rules since the publication of the 2022 interim report of the Company.

## SERVICE CONTRACTS OF DIRECTORS

### Executive Directors

Each of the Executive Directors has entered into a service contract with the Company pursuant to which they agreed to act as Executive Directors for a term of three years with effect from June 30, 2020, or June 21, 2022, which shall be renewed as determined by the Board or the shareholders of the Company. The appointment of each of the Executive Directors may be terminated by either party by giving at least three months' written notice to the other.

### Non-Executive Directors

Each of the non-Executive Directors has entered into a service contract with the Company pursuant to which they agreed to act as a non-Executive Director for a term of three years with effect from November 13, 2020, June 3, 2022 or June 14, 2022, which shall be renewed as determined by the Board or the shareholders of the Company. The appointment of each of the non-Executive Directors may be terminated by either party by giving at least three months' written notice to the other.

### Independent Non-Executive Directors

Each of the Independent non-Executive Directors has been appointed for a term of three years with effect from June 14, 2022 or June 15, 2022, which shall be renewed as determined by the Board or the shareholders of the Company. The appointment of each of the Independent non-Executive Directors may be terminated by either party giving at least three months' written notice to the other.

All of the appointments of Directors are subject to the provisions of the Articles of Association with regard to vacating the office of Directors, removal and retirement by rotation of Directors. Except for directors' fees, none of the Independent non-Executive Directors is expected to receive any other remuneration for holding their office as an Independent non-Executive Director.

None of the Directors who are proposed for re-election at the forthcoming AGM has or is proposed to have a service contract that is not terminable by the Company within one year without the payment of compensation (other than statutory compensation).

## Directors' Report

### **DIRECTOR'S INTERESTS IN TRANSACTIONS, ARRANGEMENTS AND CONTRACTS**

There were no transactions, arrangements and significant contracts with any member of the Group as the contracting party and in which the Directors and the Directors' connected party possessed direct or indirect substantial interests, and which was still valid on December 31, 2022 or at any time during such year and related to the business of the Group.

### **DIRECTORS' INTERESTS IN COMPETITIVE BUSINESS**

During the year ended December 31, 2022, none of the Directors are considered to have interest in a business which competes or is likely to compete, either directly or indirectly, with the business of the Group.

### **PERMITTED INDEMNITY**

Article 33 of the Articles of Association provides that every Director shall be indemnified out of the assets of the Company against any liability, action, proceeding, claim, demand, costs, damages or expenses, including legal expenses, whatsoever which they or any of them may incur as a result of any act or failure to act in carrying out their functions other than such liability (if any) that they may incur by reason of their own actual fraud or willful defaults. The Company has arranged for appropriate insurance coverage in respect of potential legal actions against its Directors and Senior Management during the year ended December 31, 2022 and as of the date of this report.

### **PRINCIPAL SUBSIDIARIES**

The Group's operations are conducted on a global basis through its direct or indirect subsidiaries. Details of the subsidiaries of the Company as at December 31, 2022 are set out in note 34 to the Consolidated Financial Statements.

### **MAJOR CUSTOMERS AND SUPPLIERS**

During the year ended December 31, 2022, the percentages of purchases attributable to the Group's major suppliers are as follows:

- the largest supplier: 10%
- five largest suppliers in aggregate: 30%

During the year ended December 31, 2022, the percentages of revenue attributable to the Group's major customers are as follows:

- the largest customer: 32%
- five largest customers in aggregate: 83%

As far as the Company is aware, none of the Directors nor any of his associates and none of the shareholders possessing over 5% of the interest in the share capital of the Company possessed any interests in the abovementioned suppliers and customers.

## SHARE OPTION SCHEME

Pursuant to an ordinary resolution passed on June 5, 2014, the Company adopted a share option scheme (the **Share Option Scheme**).

### 1. Purpose

The purposes of the Share Option Scheme are: (1) to align the interests of the Company's Directors and Senior Management, as well as other key employees with the Company's performance and strategic objectives so as to lay a foundation for the Company's future development and maximise the shareholders' value and (2) to attract, retain and motivate employees in key positions required for attaining the Company's strategic objectives by offering competitive general remuneration in the human resources market.

### 2. Participants

The Board may, at their discretion, invite any Directors (excluding Independent non-Executive Directors), Senior Management, as well as other key employees approved by the Board (which means those who are responsible for the decision-making, operation and management of the Company) as the Participants (as defined under the Share Option Scheme).

### 3. Maximum number of shares subject to Options (as defined under the Share Option Scheme)

- (a) The shares which may be issued upon exercise of all Options to be granted under the Share Option Scheme and any other share option scheme(s) adopted by the Company (and to which the provisions of Chapter 17 of the Listing Rules are applicable) must not in aggregate exceed 249,780,400 shares (the **Scheme Mandate Limit**), representing approximately 9.95% of the issued share capital of the Company as at the date of this report.
- (b) The Company may refresh the Scheme Mandate Limit at any time subject to prior approval of the shareholders in a general meeting and/or such other requirements prescribed under the Listing Rules from time to time. However, the Scheme Mandate Limit as refreshed shall not exceed 10% of the shares in issue as at the date of the aforesaid approval by the shareholders in a general meeting. Options previously granted under the Share Option Scheme and any other share option schemes of the Company (and to which the provisions of Chapter 17 of the Listing Rules are applicable) (including those outstanding, cancelled or lapsed in accordance with its terms or exercised), shall not be counted for the purpose of calculating the limit as refreshed.
- (c) The Company may also seek separate approval of the shareholders in a general meeting to grant Options beyond the Scheme Mandate Limit to Participants specifically identified by the Company before the aforesaid shareholders' meeting at which such approval is sought.
- (d) Subject to the requirements of the Listing Rules, the number of securities may be issued upon the exercise of all outstanding Options granted under the Share Option Scheme and any other schemes shall not exceed 30% of the relevant class of securities in issue of the Company (or its related subsidiaries) from time to time.
- (e) Unless approved by the shareholders in the manner set out in this paragraph, the total number of Shares issued and to be issued upon exercise of the Options granted and to be granted under the Share Option Scheme of the Company to each Participant (including both exercised and outstanding Options) in any 12-month period shall not exceed 1% of the total number of Shares in issue (the **Individual Limit**). Any further grant of Options to a Participant which would result in the Shares issued and to be issued upon exercise of all Options granted and to be granted to such Participant (including exercised, cancelled and outstanding Options) in the 12-month period up to and including the date of such further grant exceeding the Individual Limit shall be subject to separate approval of the shareholders in a general meeting with such Participant and his associates abstaining from voting.

## Directors' Report

- (f) Each grant of Options to any Director, Chief Executive Officer of the Company (**Chief Executive or Chief Executive Officer**) or substantial shareholder of the Company (or any of their respective associates) shall be subject to the prior approval of the Independent non-Executive Directors of the Company. Where any grant of Options to a substantial shareholder, or any of its respective associates, would result in the number of shares issued and to be issued upon exercise of all Options already granted and to be granted (including Options exercised, cancelled and outstanding) to such person in the 12 month period up to and including the date of such grant:
- (i) Representing in aggregate over 0.1% (or such other higher percentage as may from time to time be specified by the Hong Kong Stock Exchange) of the shares in issue; and
  - (ii) Having an aggregate value, based on the closing price of the Shares as stated in the daily quotations sheet issued by the Hong Kong Stock Exchange on the date on which the Board resolves to make an Offer (as defined under the Share Option Scheme) of that Option to the Participant or such other date as designated by the Board (the **Date of Grant**), in excess of HK\$5 million (or such other higher amount as may from time to time be specified by the Hong Kong Stock Exchange), such further grants of Options shall be subject to the prior approval by the shareholders (voting by way of poll) in a general meeting. The Company shall send a circular to the shareholders in accordance with the Listing Rules and all connected persons (as defined in the Listing Rules) of the Company shall abstain from voting in favour of the resolution at such general meeting.
- (g) The number of share options available for grant under the scheme mandate as at January 1, 2022 and December 31, 2022 was 179,014,910 and 166,636,790, respectively.
- (h) During the period ended December 31, 2022, there were 12,378,120 shares that may be issued in respect of options granted under the scheme, which is 0.493% of the weighted average number of shares in issue.

### 4. **Acceptance period**

A Share Option may be accepted by a Participant within a certain number of days from the date of the offer of the grant of the Option as indicated in the offer.

### 5. **Exercise period**

The period within which the Options may be exercised must expire no later than 10 years from the relevant Date of Grant.

### 6. **Minimum holding period**

The Option must be held for one year from the Date of Grant before it can be exercised. The vesting period shall be three years and one-third shall be vested at each anniversary from the Date of Grant.

### 7. **Consideration for acceptance**

The consideration payable for acceptance of the Option of grant by each Participant is HK\$1.00. If the Participant does not accept such grant of Option pursuant to the procedures specified in the respective grant agreement or notice within the stipulated timeframe, such Option shall be regarded as unaccepted and lapsed.

### 8. **Subscription Price**

The Subscription Price (as defined under the Share Option Scheme) shall be such price determined by the Board in its absolute discretion and notified to the Participant in the Offer and shall be no less than the higher of:

- (a) the closing price of a share as stated in the daily quotations sheet issued by the Hong Kong Stock Exchange on the Date of Grant;
- (b) the average closing price of the shares as stated in the daily quotations sheet issued by the Hong Kong Stock Exchange for the five business days immediately preceding the Date of Grant; or
- (c) the nominal value of a share.

## Directors' Report

9. The Share Option Scheme will remain in force for a period of 10 years commencing on the date on which the Share Option Scheme was adopted and has a remaining term of approximately 1 year as at the date of this report.

The summary of the Options granted under the Share Option Scheme that were still outstanding as at December 31, 2022 are as follows:

Grant date	Options Granted	Options held at January 1, 2022	Options granted during the year <sup>(a)</sup>	Options exercised during the year	Options cancelled/lapsed during the year	Options held at December 31, 2022	Exercise period <sup>(1)</sup>	Exercise price per share (HK\$)	Share price on the grant date <sup>(2)</sup> (HK\$)	Share price on the exercise date (HK\$)	Weighted average closing price of the Company's shares immediately before the exercise date (HK\$)	
<b>Director</b>												
LEI, Zili <sup>(a)(7)</sup>	October 25, 2022	1,667,970	-	1,667,970	-	-	1,667,970	October 25, 2022 – October 24, 2032	4.268	4.140	N/A	N/A
ZHAO, Guibin <sup>(4)</sup>	June 11, 2014	1,667,970	617,970	-	-	617,970	-	June 11, 2014 – June 10, 2024	5.150	5.150	N/A	N/A
	June 10, 2015	1,667,970	1,667,970	-	-	1,667,970	-	June 10, 2015 – June 9, 2025	8.610	8.480	N/A	N/A
	June 10, 2016	1,667,970	1,111,980	-	-	1,111,980	-	June 10, 2016 – June 9, 2026	7.584	7.340	N/A	N/A
	May 29, 2017	1,667,970	555,990	-	-	555,990	-	May 29, 2017 – May 28, 2027	11.620	11.620	N/A	N/A
	May 30, 2018	1,667,970	555,990	-	-	555,990	-	May 30, 2018 – May 29, 2028	12.456	11.960	N/A	N/A
	August 21, 2019	1,667,970	555,990	-	-	555,990	-	August 21, 2019 – August 20, 2029	6.390	6.390	N/A	N/A
MILAVEC, Robin Zane	May 30, 2018	526,730	175,580	-	-	175,580	-	May 30, 2018 – May 29, 2028	12.456	11.960	N/A	N/A
	August 21, 2019	1,667,970	555,990	-	-	555,990	-	August 21, 2019 – August 20, 2029	6.390	6.390	N/A	N/A
	October 25, 2022	2,633,650	-	2,633,650	-	-	2,633,650	October 25, 2022 – October 24, 2032	4.268	4.140	N/A	N/A
FAN, Yi <sup>(6)</sup>	June 11, 2014	526,730	526,730	-	-	526,730	-	June 11, 2014 – June 10, 2024	5.150	5.150	N/A	N/A
	June 10, 2015	526,730	526,730	-	-	526,730	-	June 10, 2015 – June 9, 2025	8.610	8.480	N/A	N/A
	June 10, 2016	526,730	225,160	-	-	225,160	-	June 10, 2016 – June 9, 2026	7.584	7.340	N/A	N/A
	May 29, 2017	526,730	175,580	-	-	175,580	-	May 29, 2017 – May 28, 2027	11.620	11.620	N/A	N/A
	May 30, 2018	526,730	175,580	-	-	175,580	-	May 30, 2018 – May 29, 2028	12.456	11.960	N/A	N/A
	August 21, 2019	526,730	175,570	-	-	175,570	-	August 21, 2019 – August 20, 2029	6.390	6.390	N/A	N/A
SHI, Shiming <sup>(8)</sup>	October 25, 2022	351,150	-	351,150	-	-	351,150	October 25, 2022 – October 24, 2032	4.268	4.140	N/A	N/A
WANG, Jian	August 21, 2019	702,300	234,100	-	-	234,100	-	August 21, 2019 – August 20, 2029	6.390	6.390	N/A	N/A
	October 25, 2022	351,150	-	351,150	-	-	351,150	October 25, 2022 – October 24, 2032	4.268	4.140	N/A	N/A
ZHANG, Wendong	October 25, 2022	351,150	-	351,150	-	-	351,150	October 25, 2022 – October 24, 2032	4.268	4.140	N/A	N/A
Sub-total		21,420,270	7,836,910	5,355,070	-	7,661,330	5,530,650					

## Directors' Report

Grant date	Options Granted	Options held at January 1, 2022	Options granted during the year <sup>(8)</sup>	Options exercised during the year	Options cancelled/lapsed during the year	Options held at December 31, 2022	Exercise period <sup>(1)</sup>	Exercise price per share	Share price on the grant date <sup>(2)</sup>	Share price on the exercise date	Weighted average closing price of the Company's shares immediately before the exercise date
											(HKS)
Other Employee Participants (in aggregate)											
June 11, 2014	9,042,160	-	-	-	-	-	June 11, 2014 – June 10, 2024	5.150	5.150	N/A	N/A
June 10, 2015	8,164,290	175,570	-	-	-	175,570	June 10, 2015 – June 9, 2025	8.610	8.480	N/A	N/A
June 10, 2016	8,407,790	630,540	-	-	-	630,540	June 10, 2016 – June 9, 2026	7.584	7.340	N/A	N/A
May 29, 2017	9,724,610	1,146,840	-	-	831,570	315,270	May 29, 2017 – May 28, 2027	11.620	11.620	N/A	N/A
May 30, 2018	10,251,340	1,953,990	-	-	1,287,560	666,430	May 30, 2018 – May 29, 2028	12.456	11.960	N/A	N/A
August 21, 2019	9,110,100	1,193,110	-	-	1,193,110	-	August 21, 2019 – August 20, 2029	6.390	6.390	N/A	N/A
October 25, 2022	7,023,050	-	7,023,050	-	-	7,023,050	October 25, 2022 – October 24, 2032	4.268	4.140	N/A	N/A
Sub-total	61,723,340	5,100,050	7,023,050	-	3,312,240	8,810,860					
Total	83,143,610	12,936,960	12,378,120	-	10,973,570	14,341,510					

## Notes:

- (1) The Options granted in 2014, 2015, 2016, 2017, 2018, 2019, and 2022 must be held for one year from June 11, 2014, June 10, 2015, June 10, 2016, May 29, 2017, May 30, 2018, August 21, 2019, and October 25, 2022 respectively. The Options are exercisable subject to, amongst other relevant vesting criteria, the vesting schedule of one-third at each anniversary of the Date of Grant of the share option.
- (2) The exercise price for the Options granted on June 11, 2014, May 29, 2017 and August 21, 2019 was the closing price of the shares quoted on the Hong Kong Stock Exchange on the trading day on the Date of Grant of the Options. The exercise price for the Options granted on June 10, 2015, June 10, 2016, May 30, 2018, and October 25, 2022 was the average closing price for five consecutive trading days prior to the Date of Grant of the Options. The closing price of the shares of the Company immediately before the date of the Options (i.e. October 24, 2022) granted during the reporting year was HK\$3.98.
- (3) Mr. LEI, Zili was appointed as our non-Executive Director with effect from June 8, 2021, appointed as the Chairman with effect from March 16, 2022 and re-designated from a non-Executive Director to an Executive Director with effect from June 21, 2022.
- (4) Mr. ZHAO, Guibin ceased to act as Executive Director and Chief Executive Officer with effect from June 14, 2022.
- (5) Mr. FAN, Yi ceased to act as Executive Director with effect from June 21, 2022.
- (6) Mr. SHI, Shiming was appointed as a non-Executive Director with effect from June 21, 2022.
- (7) Of the 5,959,600 Options to be granted to Mr. LEI, Zili, he has voluntarily given up 4,291,630 Options, resulting in 1,667,970 Options being granted.
- (8) The October 25, 2022 grant contains various performance targets in order to vest. These performance targets require the Group to achieve a minimum return on invested capital, three-year compound annual growth rate, and operating margin. Also, the Group's return on invested capital, three-year compound annual growth rate, and operating margin must exceed benchmark companies.

## PENSION SCHEMES

The Group has both defined contribution and defined benefit plans. Various subsidiaries within the Group operate various pension schemes. The schemes are generally funded through payments to insurance companies or trustee administered funds, determined by periodic actuarial calculations.

More detailed information regarding pension schemes is set out in note 17 to the Consolidated Financial Statements.

## NON-COMPETITION UNDERTAKING FROM OUR CONTROLLING SHAREHOLDERS

On June 15, 2013, each of AVIC, AVIC Auto, PCM China and Nexteer Hong Kong (together the **Controlling Shareholders**) provided a non-competition undertaking (the **Non-competition Undertaking**), pursuant to which each of the Controlling Shareholders has unconditionally and irrevocably undertaken that apart from the Retained Business as defined in the prospectus of the Company dated September 24, 2013 (the **Prospectus**) it will not, and will procure its subsidiaries not to, whether directly or indirectly through third parties or the provision of support to such third parties, engage in any automotive steering systems and driveline systems business (the **Core Business**) that competes, or is likely to compete, directly or indirectly with our Group. Details of the Non-competition Undertaking were disclosed in the Prospectus under the section headed 'Relationship with our Controlling Shareholders'.

On August 21, 2020, Yubei Steering Systems (Xinxiang) Co., Ltd. (formerly known as Yubei Steering Systems Co., Ltd.) (**Yubei Steering**) notified the Company in writing that AVIC has approved the transfer of the 24.93% equity interest in Yubei Steering. Pursuant to the Non-competition Undertaking, the Company can exercise the pre-emptive right of first refusal to acquire such interest. As of August 31, 2020, the Independent non-Executive Directors had resolved that the Company would not exercise the pre-emptive right of first refusal to acquire the 24.93% equity interest in Yubei Steering. For details, please refer to the announcement of the Company dated September 8, 2020.

For the year ended December 31, 2022, the Group has not (1) pursued or declined any new business opportunity referred to us by the Controlling Shareholders nor (2) exercised or waived the pre-emptive rights under the Non-competition Undertaking. Certain Controlling Shareholders have provided an annual confirmation of its compliance with the Non-competition Undertaking. The Independent non-Executive Directors have reviewed and were satisfied that such Controlling Shareholders have complied with the Non-competition Undertaking for the year ended December 31, 2022.

## Directors' Report

**CONTROLLING SHAREHOLDERS' INTERESTS IN CONTRACTS**

There were no contracts of significance (including for the provision of services) with any member of the Group as the contracting party and in which any of the Controlling Shareholders possessed direct or indirect substantial interests, and which was still valid on December 31, 2022 or any time during such year and related to the business of the Group.

**DIRECTORS' AND CHIEF EXECUTIVE'S INTERESTS AND SHORT POSITIONS IN THE SHARE AND UNDERLYING SHARES**

As at December 31, 2022, the interests or short positions of the Directors or Chief Executive of the Company in the Shares, underlying Shares and debentures of the Company or its associated corporations (within the meaning of Part XV of the Securities and Futures Ordinance (the **SFO**)) required to be notified to the Company and the Hong Kong Stock Exchange pursuant to Divisions 7 and 8 of Part XV of the SFO (including interest or short positions which they were taken or deemed to have under such provisions of the SFO), or which would be required, pursuant to section 352 of the SFO, to be entered in the register referred to therein, or which would be required to be notified to the Company and the Hong Kong Stock Exchange pursuant to the Model Code for Securities Transactions by Directors of Listed Issuers set out in Appendix 10 to the Listing Rules (the **Model Code**) are as follows:

**Interest in the Company**

Name	Capacity	Nature of interest	No. of underlying Shares of the Company held <sup>(1)</sup>	Approximate percentage of total issued Shares <sup>(2)</sup>
LEI, Zili	Director	Beneficial owner	1,667,970 (L)	0.07%
MILAVEC, Robin Zane	Director	Beneficial owner	2,809,230 (L)	0.11%
SHI, Shiming	Director	Beneficial owner	351,150 (L)	0.01%
WANG, Jian	Director	Beneficial owner	351,150 (L)	0.01%
ZHANG, Wendong	Director	Beneficial owner	351,150 (L)	0.01%

Notes:

(L) Denotes a long position in Shares.

(1) These represent the interests in underlying Shares in respect of the Options granted by the Company.

(2) The calculation is based on the total number of shares in issue as at December 31, 2022 of 2,509,824,293.

Except as disclosed above, as at December 31, 2022, none of our Directors and Chief Executive of the Company have any interests or short positions in the Shares, underlying Shares or debentures of the Company or its associated corporations (within the meaning of Part XV of the SFO) which were (i) recorded in the register required to be kept under section 352 of the SFO or (ii) otherwise notified to the Company and the Hong Kong Stock Exchange pursuant to the Model Code.



## DIRECTORS' RIGHTS TO ACQUIRE SHARES OR DEBENTURES

Except as disclosed above, no rights to acquire benefits by means of the acquisition of Shares in or debentures of the Company or any of its subsidiaries were granted to any Director or their respective spouse or children under 18 years of age, nor were any such rights exercised by them. Neither the Company nor any of its subsidiaries was a party to any arrangement to enable the Directors, or their respective spouse or children under 18 years of age, to acquire such rights in any other body corporate for the year ended December 31, 2022.

## SUBSTANTIAL SHAREHOLDERS' INTERESTS AND SHORT POSITIONS IN THE SHARES AND UNDERLYING SHARES

As at December 31, 2022, the following shareholders (excluding the Directors and Chief Executive of the Company) had interests or short positions in any Shares and underlying Shares of the Company which will be required to be disclosed under provisions of Division 2 and 3 of Part XV of the SFO as recorded in the register required to be kept under Section 336 of the SFO:

Name	Capacity	No. of Shares	Approximate percentage of total Issued Shares <sup>(1)</sup>
Nexteer Automotive (Hong Kong) Holdings Limited <b>(Nexteer Hong Kong)</b> <sup>(2)</sup>	Beneficial Owner	1,105,000,000 (L)	44.03%
Pacific Century Motors, Inc. <b>(PCM China)</b> <sup>(2)</sup>	Interest of controlled corporation	1,105,000,000 (L)	44.03%
AVIC Automotive Systems Holding Co., Ltd. <b>(AVIC Auto)</b> <sup>(3)</sup>	Interest of controlled corporation	1,105,000,000 (L)	44.03%
Aviation Industry Corporation of China, Ltd. <b>(AVIC)</b> <sup>(3)</sup>	Interest of controlled corporation	1,105,000,000 (L)	44.03%
Beijing E-Town International Investment & Development Co. Ltd. <sup>(4)</sup>	Interest of controlled corporation	525,000,000 (L)	20.92%
Beijing E-Town International Automotive Investment & Management Co., Ltd. <sup>(4)</sup>	Beneficial Owner	525,000,000 (L)	20.92%

Notes:

(L) Denotes a long position in Shares.

(1) The calculation is based on the total number of 2,509,824,293 Shares in issue as at December 31, 2022.

(2) Nexteer Hong Kong is wholly-owned by PCM China, which is in turn owned as to 72.88% by AVIC Auto and as to 27.12% by Beijing E-Town International Automotive Investment & Management Co., Ltd. (北京亦莊國際汽車投資管理有限公司) (a direct wholly-owned subsidiary of Beijing E-Town International Investment & Development Co., Ltd.). Each of PCM China and AVIC Auto is deemed to be interested in the 1,105,000,000 Shares held by Nexteer Hong Kong.

(3) AVIC Auto is owned as to 70.11% by AVIC. AVIC is deemed to be interested in the 1,105,000,000 Shares held by Nexteer Hong Kong.

(4) On September 23, 2022, Beijing E-Town International Automotive Investment & Management Co., Ltd. (北京亦莊國際汽車投資管理有限公司) (a direct wholly-owned subsidiary of Beijing E-Town International Investment & Development Co., Ltd.) became a direct holder of 525,000,000 shares of the Company. Beijing E-Town International Investment & Development Co., Ltd. is deemed to be interested in the 525,000,000 Shares held by Beijing E-Town International Automotive Investment & Management Co., Ltd.

## Directors' Report

## DISCLOSURE OF INTERESTS OF SUBSTANTIAL SHAREHOLDERS OF OTHER MEMBERS OF OUR GROUP

So far as our Directors are aware, as at December 31, 2022, the persons other than our Directors and our Chief Executive who were directly interested in 10% or more of the issued and outstanding share capital of our subsidiaries carrying rights to vote in all circumstances at general meetings of each relevant subsidiary, were as follows:

Member of our Group	Person with 10% or more interest (other than the Company)	Capacity	Percentage of the substantial shareholder's interest
Nexteer Lingyun Driveline (Zhuozhou) Co., Ltd.	Lingyun Industrial Corp., Ltd.	Registered owner	40%
Nexteer Lingyun Driveline (Wuhu) Co., Ltd.	Lingyun Industrial Corp., Ltd.	Registered owner	40%
Chongqing Nexteer Steering Systems Co., Ltd.	Chongqing Jianshe Industry (Group) Co., Ltd.	Registered owner	50%
CNXMotion, LLC	Continental Automotive Systems, Inc.	Registered owner	50%
Dongfeng Nexteer Steering Systems (Wuhan) Co., Ltd.	Dongfeng Motor Parts and Components (Group) Co., Ltd.	Registered owner	50%

Except as disclosed above, as at December 31, 2022, our Directors are not aware of any person who, as at December 31, 2022, was, directly or indirectly, interested in 10% or more of the nominal value of any class of share capital carrying voting rights to vote in all circumstances at general meetings of any other member of our Group.

## CONNECTED TRANSACTIONS

The Group's related parties transactions for the year ended December 31, 2022 set out in note 31 to the Consolidated Financial Statements did not constitute connected transactions or continuing connected transactions (as defined in Chapter 14A of the Listing Rules).

## PURCHASE, REDEMPTION OR SALE OF LISTED SECURITIES OF THE COMPANY

For the year ended December 31, 2022, neither the Company nor any of its subsidiaries purchased, redeemed or sold any of the Company's listed securities.

## MANAGEMENT CONTRACTS

No contracts concerning the management and administration of the whole or any substantial part of the business of the Group were entered into or existed for the year ended December 31, 2022.

## PUBLIC FLOAT

Based on information that is publicly available to the Company and within the knowledge of the Directors as at the latest practicable date prior to the issue of the annual report, the Company has maintained the public float as required by the Listing Rules up to the date of this annual report.

## PROFESSIONAL TAX ADVICE RECOMMENDED

If the shareholders of the Company are unsure about the taxation implications of purchasing, holding, disposing of, dealing in or the exercise of any rights in relation to the Shares of the Company, they are advised to consult an expert.

## AUDITOR

The Consolidated Financial Statements have been audited by Deloitte Touche Tohmatsu, the Company's external auditor.

The Consolidated Financial Statements for the years ended December 31, 2019 and 2020 have been audited by PricewaterhouseCoopers. On June 8, 2021 PricewaterhouseCoopers retired as auditor of the Company and Deloitte Touche Tohmatsu was appointed as auditor of the Company following the retirement of PricewaterhouseCoopers.

## CLOSURE OF REGISTER OF MEMBERS

The Company's AGM will be held on June 20, 2023. For determining the entitlement to attend and vote at the AGM, the register of members of the Company will be closed from June 15, 2023 to June 20, 2023, both days inclusive, during which period no transfer of Shares will be registered. In order to be eligible to attend and vote at the AGM, all transfers accompanied by the relevant share certificates must be lodged with the Company's Share Registrar in Hong Kong, Computershare Hong Kong Investor Services Limited at Shops 1712-1716, 17th Floor, Hopewell Centre, 183 Queen's Road East, Wanchai, Hong Kong for registration no later than 4:30 p.m. on June 14, 2023.

The final dividend is payable on July 10, 2023 and the record date for entitlement to the proposed final dividend is June 29, 2023. For determining the entitlement to the proposed final dividend, the register of members of the Company will be closed from June 27, 2023 to June 29, 2023, both days inclusive, during which no transfer of Shares will be registered. In order to qualify for the proposed final dividend, all transfers accompanied by the relevant share certificates must be lodged with the Company's Share Registrar in Hong Kong, Computershare Hong Kong Investor Services Limited (address as per above) for registration no later than 4:30 p.m. on June 26, 2023.

On behalf of the Board

**Mr. LEI, Zili**

*Chairman and Chief Executive Officer*

Hong Kong, March 15, 2023

# Corporate Governance Report

## CORPORATE GOVERNANCE PRACTICES

The Company is committed to maintaining high standards of corporate governance. The Company recognises that sound corporate governance practices are fundamental to our effective and transparent operation and to the Group's ability to protect the rights of the Shareholders and enhance shareholder value.

The Company has adopted its own Internal Control and Corporate Governance Policies, which are based on the principles, provisions and practices set out in the Corporate Governance Code (the **Hong Kong CG Code**) contained in Appendix 14 to the Listing Rules.

Except as expressly described below, in the opinion of the directors of the Board (the **Directors**), the Company has complied with all applicable code provisions set out in the Hong Kong CG Code and all applicable laws and regulations that have a significant impact on the business and operation of the Group throughout the year ended December 31, 2022.

The Company periodically reviews its corporate governance practices with reference to the latest developments of the Hong Kong CG Code.

### Chairman and Chief Executive Officer

Pursuant to code provision C.2.1 in Part 2 of Appendix 14 to the Listing Rules, the roles of chairman and the chief executive should be segregated and should not be performed by the same individual. The division of responsibilities between the chairman and chief executive should be clearly established and set out in writing. With effect from June 21, 2022, Mr. LEI, Zili (**Mr. LEI**), the Chairman of the Board (the **Chairman**), has been appointed as the Chief Executive Officer of the Company, which constitutes a deviation from code provision C.2.1 in Part 2 of Appendix 14 to the Listing Rules. The Board considers that the appointment of Mr. LEI as both chairman and chief executive can provide the Group with consistent leadership going forward and allow more effective implementation of the overall strategy of the Group. Furthermore, this structure does not compromise the balance of power and authority, as major decisions are made in consultation with the Board. The current senior management team of the Group also possesses rich knowledge and experience in different professional fields to assist Mr. LEI to make decisions about the businesses and operations of the Group.

The Chairman is responsible for providing leadership to, and overseeing the functioning of, the Board to ensure that it acts in the best interests of the Group and that Board meetings are planned and conducted effectively. The Chairman is responsible for setting the agenda for each Board meeting, taking into account, where appropriate, matters proposed by the Directors and the Company Secretary. With the support of the Executive Directors and the Company Secretary, the Chairman seeks to ensure that all Directors are properly briefed on issues arising at Board meetings and provided with adequate and accurate information in a timely manner. The Chairman promotes a culture of openness and actively encourages Directors to voice their opinion and be fully engaged in the Board's affairs so as to contribute to the Board's effective functioning. The Board, under the leadership of the Chairman, has adopted sound corporate governance practices and procedures and has taken appropriate steps to provide effective communication with Shareholders and other stakeholders.

## Corporate Governance Report

**Non-Compliance with the Requirements Under the Listing Rules**

Immediately following the removal of Mr. ZHAO, Guibin and Mr. YICK, Wing Fat Simon as Directors at the extraordinary general meeting of the Company held on June 14, 2022, the Company failed to comply with the requirements under the Listing Rules as follows:

- (i) the audit and compliance committee of the Board (the **Audit and Compliance Committee**) consisted of two members, of which one member (i.e. the chairman) was an Independent non-Executive Director, therefore the Audit and Compliance Committee had failed to meet the requirements under rule 3.21 of the Listing Rules that an audit committee must comprise a minimum of three members, and the majority of whom must be independent non-executive directors;
- (ii) the remuneration and nomination committee of the Board (the **Remuneration and Nomination Committee**) consisted of two members, of which one member was an Independent non-Executive Director, therefore the Remuneration and Nomination Committee had failed to meet the requirements under rule 3.25 of the Listing Rules that a remuneration committee must be chaired by an independent non-executive director and comprise a majority of independent non-executive directors. Furthermore, it had also failed to meet the requirements under rule 3.27A of the Listing Rules that a nomination committee must be chaired by the chairman of the board or an independent non-executive director and comprise a majority of independent non-executive directors; and
- (iii) the Company had only appointed one authorised representative pursuant to the Listing Rules, and failed to meet the requirements under rule 3.05 of the Listing Rules that the issuer should appoint two authorised representatives, who shall act as the listed issuer's principal channel of communication with the Hong Kong Stock Exchange.

Following changes in the composition of the committees of the Board which took effect from June 21, 2022, the Company has fully complied with the requirements as set out in rules 3.21, 3.25, 3.27A and 3.05 of the Listing Rules. For details, please refer to the Company's announcements dated June 14, 2022 and June 21, 2022.

**COMPLIANCE WITH CODE OF CONDUCT REGARDING DIRECTORS' SECURITIES TRANSACTIONS**

The Company has adopted the Model Code as set out in Appendix 10 to the Listing Rules as the Company's code of conduct regarding securities transactions by the Directors of the Company. Having made specific enquiry of all Directors, all Directors have confirmed that they complied with the required standards set out in the Model Code for the year ended December 31, 2022.

The Company has also adopted its own code of conduct regarding employees' securities transactions in terms no less exacting than the standard set out in the Model Code for the compliance by its relevant employees who are likely to be in possession of unpublished inside information of the Company in respect of their dealings in the Company's securities.

The Company maintains and regularly reviews a sensitivity list identifying factors or developments which are likely to give rise to the emergence of inside information or development of a false market for its securities.

The Company ensures that confidentiality agreements are signed by all relevant parties to a transaction that is likely to give rise to the emergence of inside information or development of a false market for its securities. The Company also adopts appropriate measures to maintain the confidentiality of the information, such as using project codes and restricting access to such information to a limited group of recipients on a need-to-know basis.

The Company organises periodic training as it deems necessary for employees who, because of their office or employment, are likely to be in possession of inside information in relation to the Company, to help them understand the Company's policies and procedures as well as their relevant disclosure duties and obligations.

## Corporate Governance Report

### THE BOARD OF DIRECTORS AND SENIOR MANAGEMENT

The Board is responsible for leadership and control of the Company and the Group and for promoting the success of the Group by directing and supervising the Group's affairs. In addition, the Board is responsible for overseeing ESG issues. The Board is also responsible for overseeing the corporate governance and financial reporting of the Company and for reviewing the effectiveness of the Group's system of internal control and risk management. To assist it in fulfilling its duties, the Board has established two board committees: the Audit and Compliance Committee and the Remuneration and Nomination Committee.

The Group is managed collectively by our core management team, which is comprised of the Board and Senior Management of the Group. Members of our Senior Management are responsible for overseeing their respective divisions and functions and making day-to-day decisions of the Group. They meet regularly to discuss issues of their respective functions and make relevant decisions and report to our Board regularly and when necessary. Our Senior Management as a whole is also responsible for formulating the overall strategies, annual budget, key business, financial and other operational policies and preparing proposals of any key business, financial and other operational decisions of the Group taking into account inputs from different functions for the Board's approval. The Board will consult with our Senior Management on such proposals and discuss the same at the Board level with an aim to reach a consensus that is in the best interest of the Group. Once the key policies and decisions are formulated and made, our Senior Management as a whole will implement the same throughout the Group. Accordingly, the overall strategic and other key business, financial and operational policies and decisions of the Group are made collectively from its inception to implementation after thorough discussion at both Board and Senior Management levels.

The Board has established clear guidelines with respect to matters that must be approved or recommended by the Board, including, without limitation, approval and adoption of the Group's annual operating budget and capital expenditure budget; the hiring or dismissal of the Chief Executive Officer, Chief Financial Officer (the **CFO**), Company Secretary or certain other members of the Senior Management team; and approving and recommending significant transactions. The Group has arranged for appropriate insurance coverage in respect of potential legal actions against its Directors and Senior Management.

#### **Composition of the Board, Number of Board Meetings and Directors' Attendance**

As at December 31, 2022, the Board consists of eight Directors, including two Executive Directors, namely LEI, Zili (Chairman) and MILAVEC, Robin Zane, three non-Executive Directors namely WANG, Jian (resigned as Chairman with effect from March 16, 2022), ZHANG, Wendong and SHI, Shiming and three Independent non-Executive Directors, namely LIU, Jianjun, WANG, Bin and YUE, Yun. The biographical details of each current Director and their respective responsibilities and dates of appointment are included in the section headed 'Directors and Senior Management' of this annual report. None of the Directors or chief executive is related to one another.

## Corporate Governance Report

The following is the attendance record of the Directors at the Board and committee meetings, and general meetings held for the year ended December 31, 2022:

Name of Director	Attendance/number of Meetings in 2022				
	Board	Remuneration and Nomination Committee	Audit and Compliance Committee	Annual General Meeting	Extraordinary General Meeting
LEI, Zili (雷自力) <sup>(1)</sup>	4/4	N/A	1/1	1/1	1/1
MILAVEC, Robin Zane	4/4	N/A	N/A	1/1	1/1
ZHAO, Guibin (趙桂斌) <sup>(2)</sup>	1/1	N/A	N/A	N/A	1/1
FAN, Yi (樊毅) <sup>(3)</sup>	2/2	N/A	N/A	1/1	1/1
WANG, Jian (王堅) <sup>(4)</sup>	4/4	N/A	N/A	0/1	1/1
ZHANG, Wendong (張文冬)	3/4	2/2	N/A	1/1	1/1
SHI, Shiming (石仕明) <sup>(5)</sup>	3/3	N/A	2/2	1/1	N/A
LIU, Jianjun (劉健君)	4/4	2/2	N/A	1/1	1/1
WANG, Bin (王斌) <sup>(6)</sup>	3/3	1/1	2/2	1/1	N/A
YUE, Yun (岳雲) <sup>(7)</sup>	3/3	N/A	2/2	1/1	N/A
WEI, Kevin Cheng (蔚成) <sup>(8)</sup>	2/2	N/A	1/1	0/1	1/1
YICK, Wing Fat Simon (易永發) <sup>(9)</sup>	1/1	1/1	1/1	N/A	0/1

Notes:

- (1) Mr. LEI, Zili was appointed as the Chairman and ceased to act as a member of the Audit and Compliance Committee with effect from March 16, 2022.
- (2) Mr. ZHAO, Guibin ceased to act as an Executive Director with effect from June 14, 2022.
- (3) Mr. FAN, Yi ceased to act as an Executive Director with effect from June 21, 2022.
- (4) Mr. WANG, Jian was appointed as a member of the Audit and Compliance Committee with effect from March 16, 2022 and ceased to act with effect from June 21, 2022.
- (5) Mr. SHI, Shiming was appointed as a non-Executive Director and a member of the Audit and Compliance Committee with effect from June 21, 2022.
- (6) Dr. WANG, Bin was appointed as an Independent non-Executive Director, the chairman of the Audit and Compliance Committee and a member of the Remuneration and Nomination Committee with effect from June 21, 2022.
- (7) Mr. YUE, Yun was appointed as an Independent non-Executive Director and a member of the Audit and Compliance Committee with effect from June 21, 2022.
- (8) Mr. WEI, Kevin Cheng ceased to act as an Independent non-Executive Director and the chairman of the Audit and Compliance Committee with effect from June 21, 2022.
- (9) Mr. YICK, Wing Fat Simon ceased to act as an Independent non-Executive Director, a member of the Audit and Compliance Committee and a member and the chairman of the Remuneration and Nomination Committee with effect from June 14, 2022.

## Corporate Governance Report

### **PRACTICES AND CONDUCT OF MEETINGS**

Notice of regular Board meetings is given to all Directors at least 14 days in advance, and reasonable notice is generally given for other Board meetings. Annual meeting schedules and the draft agenda of each meeting are normally made available to Directors in advance. Arrangements are in place to allow Directors to include items in the agenda, and final agendas together with relevant supporting documents are sent to Directors at least 3 days before each regular Board meeting, and as soon as practicable before other Board meetings, so that the Board can make informed decisions on matters placed before it. Each Director also has separate and independent access to the Senior Management where necessary. Minutes of the Board meetings are kept by the Company Secretary. Draft minutes are circulated to Directors for comment within a reasonable time after each meeting.

If a Director or any of their associates has a material interest in a transaction, that Director is required to abstain from voting and not to be counted in the quorum at the meeting for approving the transaction.

### **INDEPENDENCE OF INDEPENDENT NON-EXECUTIVE DIRECTORS**

During the year ended December 31, 2022, the Board met the requirements of the Listing Rules relating to the appointment of at least three Independent non-Executive Directors representing one-third of the Board with one of whom possessing appropriate professional qualifications or accounting or related financial management expertise.

The Company has received written confirmation from each of the Independent non-Executive Directors in respect of his independence in accordance with the independence guidelines set out in Rule 3.13 of the Listing Rules. The Company considers all Independent non-Executive Directors to be independent.

### **BOARD INDEPENDENCE**

In order to ensure that independent views and input of the Independent non-Executive Directors are made available to the Board, the Remuneration and Nomination Committee and the Board are committed to assess the Directors' independence annually with regards to all relevant factors related to the Independent non-Executive Directors including the following:

- required character, integrity, expertise, experience and stability to fulfill their roles;
- time commitment and attention to the Company's affairs;
- firm commitment to their independent roles and to the Board;
- declaration of conflict of interest in their roles as independent non-executive Directors;
- no involvement in the daily management of the Company nor in any relationship or circumstances which would affect the exercise of their independent judgement; and
- the Chairman meets with the Independent non-executive Directors regularly without the presence of the Executive Directors.

All Directors are entitled to seek advice from the Company Secretary as well as from independent professional advisors at the Company's expenses. During the reporting period, the Company has reviewed the mechanisms established to ensure independent views and input are available to the Board and was satisfied with the implementation and effectiveness of such mechanisms.



## APPOINTMENT AND RE-ELECTION OF DIRECTORS

The Company uses a formal and transparent procedure for the appointment, election and removal of Directors, which is set out in the Company's Articles of Association and is led by the Remuneration and Nomination Committee, which will make recommendations on appointment of new Directors to the Board for approval.

Further details relating to the appointment, election and removal of Directors and the service contracts of Directors are set out in the sections headed 'Directors' and 'Service Contracts of Directors' in the Directors' Report included in this annual report.

## CONTINUOUS PROFESSIONAL DEVELOPMENT OF DIRECTORS

Each newly appointed Director receives a comprehensive introduction to the Company in order to ensure his understanding of the business and operations of the Group and awareness of a director's responsibilities and obligations. All Directors are encouraged to participate in continuous professional development to develop and refresh their knowledge by attending internal training and external seminars. For the year ended December 31, 2022, the Company arranged in-house training for all Directors relating to on-going compliance obligations, corporate governance and other related topics.

During the year ended December 31, 2022, the Directors participated in the following training:

Directors	Types of training
<b>Executive Directors</b>	
LEI, Zili ( <i>Chairman</i> )	A, B, C, D
MILAVEC, Robin Zane	A, B, C, D
<b>Non-Executive Directors</b>	
WANG, Jian	A, C, D
ZHANG, Wendong	A, B, C, D
SHI, Shiming (appointed with effect from June 21, 2022)	B, C, D
<b>Independent Non-Executive Directors</b>	
LIU, Jianjun	A, C
WANG, Bin (appointed with effect from June 21, 2022)	A, B, C, D
YUE, Yun (appointed with effect from June 21, 2022)	A, B, C, D

A: attending seminars and/or conferences and/or forums

B: giving talks at seminars and/or conferences and/or forums

C: attending in-house training relating to the on-going compliance obligations, corporate governance and other related topics

D: reading newspapers, journals, Company's newsletters and updates relating to the economy, general business, automotive component manufacturing industry or Directors' duties and responsibilities, etc.

## COMMITTEES

The Board has established the Audit and Compliance Committee, and the Remuneration and Nomination Committee for overseeing particular aspects of the Group's affairs. All Board committees are established with defined written terms of reference which are posted on the Company's website, the Hong Kong Stock Exchange's website and are available to shareholders upon request. Meetings of the Board committees generally follow the same procedures as meetings of the Board.

## Corporate Governance Report

### THE AUDIT AND COMPLIANCE COMMITTEE

The Board established the Audit and Compliance Committee on June 15, 2013 and had provided clear written terms of reference as required by code provision in C.4.1 in Part 2 of the Hong Kong CG Code. The terms of reference are in compliance with Rule 3.21 of the Listing Rules and code provisions D.3.3 and A.2.1 in Part 2 of the Hong Kong CG Code. The Audit and Compliance Committee consists of Dr. WANG, Bin (appointed with effect from June 21, 2022), Mr. SHI, Shiming (appointed with effect from June 21, 2022) and Mr. YUE, Yun (appointed with effect from June 21, 2022). All members of the Audit and Compliance Committee are non-Executive Directors, among whom Dr. WANG, Bin and Mr. YUE, Yun are Independent non-Executive Directors. The chairman of the Audit and Compliance Committee is Dr. WANG, Bin who holds the appropriate professional qualifications as required under Rules 3.10(2) and 3.21 of the Listing Rules. The primary duties of the Audit and Compliance Committee include, without limitation, assisting our Board by providing an independent view of the effectiveness of the financial reporting process, risk management and internal control system of the Group, overseeing the audit process and performing other duties and responsibilities as assigned by the Board.

The Board recognises that corporate governance should be the collective responsibility of the Directors and delegates the corporate governance duties to the Audit and Compliance Committee which include:

- reviewing and monitoring the Group's policies and practices on compliance with legal and regulatory requirements;
- developing, reviewing and monitoring the code of conduct and compliance manual (if any) applicable to employees and Directors;
- developing and reviewing the Company's policies and practices on corporate governance and making recommendations to the Board and report to the Board on matters;
- reviewing the Company's compliance with the Hong Kong CG Code and disclosure in the Corporate Governance Report; and
- considering any other topics, as determined by the Board.

## Corporate Governance Report

There were three meetings of the Audit and Compliance Committee held for the year ended December 31, 2022, the attendance record of the committee members is set out above. The following is a summary of the major work performed by the Audit and Compliance Committee during 2022:

- reviewed the reports and findings from management including Internal Audit on the implementation and refinement of the risk management and internal control measures;
- reviewed the Internal Audit plan;
- confirmed the independence and objectivity of the Company's external auditor, Deloitte Touche Tohmatsu;
- met with the external auditor and reviewed their 2022 audit plan;
- reviewed the annual results and the adequacy of the risk management and internal control system for the year ended December 31, 2021; and
- reviewed the interim results for the six months ended June 30, 2022.

Subsequent to December 31, 2022 and up to the date of this annual report, a meeting of the Audit and Compliance Committee was held on March 14, 2023 to review the annual results and the adequacy of the risk management and internal control system for the year ended December 31, 2022.

## THE REMUNERATION AND NOMINATION COMMITTEE

The Board established the Remuneration and Nomination Committee on June 15, 2013 and had provided clear written terms of reference as required by code provision in C.4.1 in Part 2 of the Hong Kong CG Code. The terms of reference (as revised on August 15, 2017) are in compliance with code provisions B.3.1 and E.1.2 in Part 2 of the Hong Kong CG Code. These terms of reference include appropriate professional knowledge and industry experience, personal ethics, integrity and personal skill as well as time commitments of members. The Remuneration and Nomination Committee consists of, Mr. LIU, Jianjun (appointed as Chairman with effect from June 21, 2022), Ms. ZHANG, Wendong and Dr. WANG, Bin (appointed with effect from June 21, 2022). All members of the Remuneration and Nomination Committee are non-Executive Directors, among whom Mr. LIU, Jianjun and Dr. WANG, Bin are Independent non-Executive Directors. The chairman of the Remuneration and Nomination Committee is Mr. LIU, Jianjun. The primary functions of the Remuneration and Nomination Committee include, without limitation, (i) making recommendations to the Board on our policy and structure for all remuneration of Directors and Senior Management and on the establishment of a formal and transparent procedure for developing policy on such remuneration; (ii) making recommendations on the remuneration packages of Executive and non-Executive Directors and Senior Management; (iii) reviewing and approving Senior Management's remuneration proposals with reference to corporate goals and objectives resolved by the Board from time to time; (iv) reviewing the structure, size, composition and diversity of the Board; (v) assessing the independence of Independent non-Executive Directors; (vi) making recommendations to the Board on matters relating to the appointment of Directors; and (vii) reviewing and/or approving matters relating to share schemes under Chapter 17 of the Listing Rules.

The remuneration of Directors and Senior Management is determined with reference to their expertise and experience in the industry, the performance and profitability of the Group as well as remuneration benchmarks from other local and international companies and prevailing market conditions. Directors and employees also participate in bonus arrangements which are determined in accordance with the performance of the Group and the individual's performance. No Director or any of their associates takes part in any discussion about their own remuneration.

## Corporate Governance Report

There were two meetings of the Remuneration and Nomination Committee held for the year ended December 31, 2022, the attendance record of the committee members is set out above. The following is a summary of the major work performed by the Remuneration and Nomination Committee during 2022:

- nominated Chairman of the Board;
- nominated the Chief Executive Officer;
- nominated one non-Executive Director;
- nominated two Independent non-Executive Directors;
- reviewed and made a recommendation to the Board regarding the fees of the Independent non-Executive Directors and the Senior Management;
- reviewed and approved the seventh grant under the Share Option Scheme;
- reviewed the Chief Executive Officer employment agreement;
- reviewed the Board structure, size, composition and board diversity (including ability, knowledge and experience etc.);
- confirmed the independence of the Independent non-Executive Directors; and
- considered the retirement and re-nomination of Directors for re-election at the AGM.

### **BOARD DIVERSITY POLICY**

The Company recognises and embraces the benefits of having a diverse Board to enhance the quality of its performance. To that end, the Company has adopted a Board diversity policy to set out the approach to achieve diversity on the Board. With a view to achieving a sustainable and balanced development, the Company sees increasing diversity at the Board level as an essential element in supporting the attainment of its strategic objectives and its sustainable development. In designing the Board's composition, Board diversity has been considered from a number of aspects, including but not limited to gender, age, ethnicity, years of work experience, and professional experience. The Company will develop and maintain pipeline of potential successors to the Board to maintain diversity based on such aspects. All Board appointments will be based on meritocracy, and candidates will be considered against objective criteria, having due regard for the benefits of diversity on the Board. The Company continues to pursue board diversity in multiple aspects, including appointment of a female Director to the Board in 2020. A visual snapshot of the Board's diversity and certain measurable objectives as at December 31, 2022 is shown on this page.

## DIVERSITY SNAPSHOTS

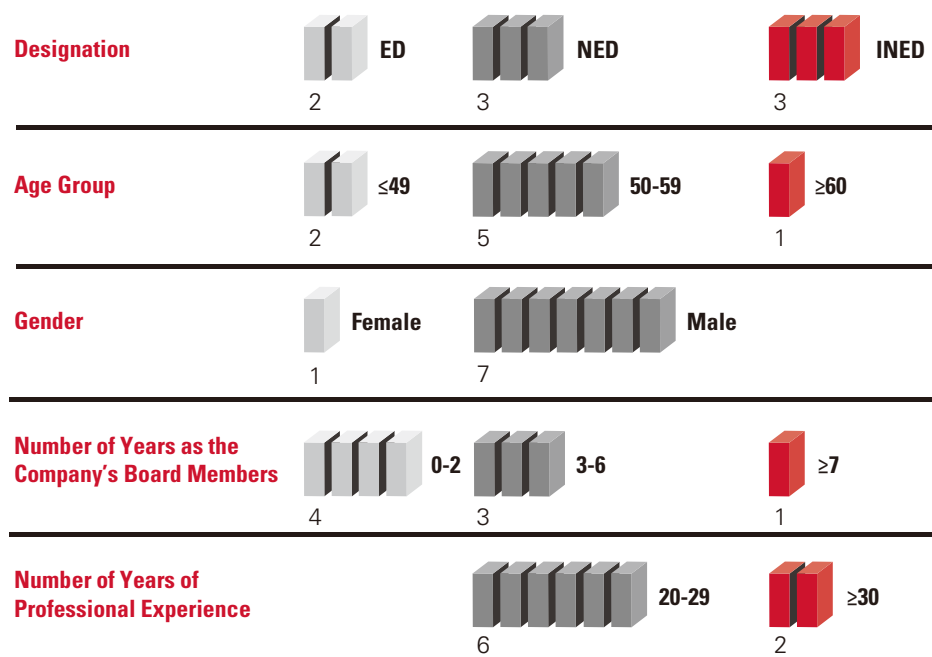

Directors	Professional experiences include
LEI, Zili	automotive, aviation technology, strategy, business administration
MILAVEC, Robin Zane	automotive, engineering strategy, operations, business administration economics, management
WANG, Jian	automotive, aviation technology, strategy, corporate governance, operation management, finance, economics
ZHANG, Wendong	investment, strategy, international marketing management, finance, business administration, economics
SHI, Shiming	finance, accounting, risk management, investment, compliance
LIU, Jianjun	legal, compensation and compliance
WANG, Bin	finance, corporate governance, risk management, compensation, compliance
YUE, Yun	legal, internal control, investment, risk management

The Board currently has one female Director out of eight Directors, and is committed to improving gender diversity as and when suitable candidates are identified. The Company is of the view that gender diversity in respect of the Board has been achieved. Of the approximately 12,600 employees (including senior management) of the Group as at December 31, 2022, approximately 3,350 are female. Accordingly, the Company considers that gender diversity is also achieved in its workforce generally.

During the year ended December 31, 2022, the Board, through the Remuneration and Nomination Committee, has reviewed the implementation and effectiveness of the Board diversity policy and confirm that the Board has an appropriate mix of skills and experience to deliver the Company's strategy.

## Corporate Governance Report

### **NOMINATION POLICY**

The Remuneration and Nomination Committee shall nominate suitable candidates to the Board for it to consider and make recommendations to shareholders for election as directors of the Company at general meetings or to appoint as directors to fill casual vacancies. The Remuneration and Nomination Committee may, as it considers appropriate, nominate a number of candidates more than the number of directors to be appointed or re-appointed at a general meeting, or the number of casual vacancies to be filled.

The factors listed below would be used as reference by the Remuneration and Nomination Committee in assessing the suitability of a proposed candidate: reputation for integrity and good character; judgment and diversity of experience in all its aspects, including but not limited to gender, age, ethnicity, years of work experience, and professional experience – including educational background, skills and knowledge; commitment to the Company in respect of available time and relevant interest; ability to provide insight in relation to the Company's line of business; requirement for the Board to have independent non-executive directors in accordance with the Listing Rules; whether the candidate would be considered independent with reference to the independence guidelines set out in the Listing Rules, taking into account factors like the candidate's relationship with the existing directors and any substantial interest in the Company; understanding of the fiduciary duties required; and compliance with the Board Diversity Policy and any measurable objectives adopted by the Remuneration and Nomination Committee for achieving diversity on the Board. These factors are for reference only, and not meant to be exhaustive and decisive. The Remuneration and Nomination Committee has the discretion to nominate any person, as it considers appropriate. Proposed candidates will be asked to submit the necessary personal information in a prescribed form, together with their written consent to be appointed as a director and to the public disclosure of their personal data on any documents or the relevant websites for the purpose of or in relation to their standing for election as a director. The Remuneration and Nomination Committee may request candidates to provide additional information and documents, if considered necessary.

The secretary of the Remuneration and Nomination Committee shall call a meeting of the Remuneration and Nomination Committee, and invite nominations of candidates from Board members if any, for consideration by the Remuneration and Nomination Committee prior to its meeting. For filling a casual vacancy, the Remuneration and Nomination Committee shall make recommendations for the Board's consideration and approval. For proposing candidates to stand for election at a general meeting, the Remuneration and Nomination Committee shall make nominations to the Board for its consideration and recommendation. Until the issue of the shareholder circular, the nominated persons shall not assume that they have been proposed by the Board to stand for election at the general meeting. Nomination procedures to be followed by the shareholders shall be in accordance with the Articles of Association (as amended and/or from time to time). A candidate is allowed to withdraw his candidature at any time before the general meeting by serving a notice in writing to the Company Secretary. The Board shall have the final decision on all matters relating to its recommendation of candidates to stand for election at any general meeting.

### **DIVIDEND POLICY**

The declaration of dividends is subject to the discretion of the Board and the approval of the Company's shareholders. Subject to applicable laws and regulations, the Company currently intends to pay dividends of not less than 20% of its net profits available for distribution. The Board may recommend a payment of dividends in the future after taking into account the Company's operations and earnings, capital requirements and surplus, general financial condition, contractual restrictions, capital expenditures and future development requirements, shareholders' interests and other factors which they may deem relevant at such time. Any declaration and payment as well as the amount of the dividends will be subject to the Company's constitutional documents and the Companies Law (as amended) of the Cayman Islands including the approval of the Company's shareholders. Any future declarations of dividends may or may not reflect the Company's historical declarations of dividends and will be at the absolute discretion of the Board.

## Corporate Governance Report

## AUDITOR'S REMUNERATION

The Company's external auditor is Deloitte Touche Tohmatsu. A breakdown analysis of the remuneration paid to Deloitte Touche Tohmatsu for the year ended December 31, 2022 is set out below. The Audit and Compliance Committee has confirmed the independence and objectivity of the external auditor.

Service Category	Fees Paid US\$'000
Audit Services	1,791
Non-audit Services	433
Total	2,224

Non-audit services include allowable tax consulting and compliance services.

## COMPANY SECRETARY

The company secretary of the Company is responsible for advising the Board on corporate governance matters and ensuring that the Board policies and procedures, as well as the applicable laws, rules and regulations are followed.

In order to uphold good corporate governance and ensure compliance with the Listing Rules and applicable Hong Kong laws, the Company engages Ms. CHU, Cheuk Ting (**Ms. CHU**), a manager of the Listing Services Department of TMF Hong Kong Limited (a company secretarial service provider), as the company secretary. Mr. Crist Wu, the executive director of Board Affairs and Investor Relations, is the primary corporate contact person at the Company whom Ms. CHU contacts.

For the year ended December 31, 2022, Ms. CHU has undertaken not less than 15 hours of relevant professional training respectively in compliance with Rule 3.29 of the Listing Rules.

## SHAREHOLDERS' RIGHTS

To safeguard shareholders' interests and rights, a separate resolution is proposed for each substantially separate issue at general meetings, including the election of individual Directors. Except where the Chairman, in good faith, decides to allow a resolution which relates purely to a procedural or administrative matter to be voted on by a show of hands, all resolutions put forward at general meetings will be voted on by poll pursuant to the Listing Rules. Poll results will be posted on the websites of the Company and of the Hong Kong Stock Exchange after each general meeting. There are no provisions under the laws of the Cayman Islands or the Articles of Association that allows shareholders to make proposals or move resolutions at an annual general meeting. Shareholders of the Company who wish to make proposals or move a resolution may, however, request the Board to convene an extraordinary general meeting by following the procedures below.

## PROCEDURES FOR SHAREHOLDERS TO CONVENE AN EXTRAORDINARY GENERAL MEETING

Extraordinary general meetings may be convened on the written request of any two or more shareholders of the Company deposited at the principal place of business of the Company in Hong Kong or, in the event the Company ceases to have such a principal place of business, the registered office specifying the objects of the meeting and signed by the requestors, provided that such requestors held as at the date of deposit of the request not less than one-tenth of the paid up capital of the Company which carries the right of voting at general meetings of the Company.

## Corporate Governance Report

Extraordinary general meetings may also be convened on the written request of any one shareholder of the Company which is a recognised clearing house (or its nominee(s)) deposited at the principal place of business of the Company in Hong Kong or, in the event the Company ceases to have such a principal place of business, the registered office specifying the objects of the meeting and signed by the requestor, provided that such requestor held as at the date of deposit of the requisition not less than one-tenth of the paid up capital of the Company which carries the right of voting at general meetings of the Company.

If the Board does not within 21 days from the date of deposit of the request proceed duly to convene the extraordinary general meeting to be held within a further 21 days, the requestor(s) themselves, or any of them representing more than one-half of the total voting rights of all of them, may convene the extraordinary general meeting in the same manner, as nearly as possible, as that in which meetings may be convened by the Board provided that any meeting so convened shall not be held after the expiration of three months from the date of deposit of the request, and all reasonable expenses incurred by the requestor(s) as a result of the failure of the Board shall be reimbursed to them by the Company.

### SHAREHOLDERS' ENQUIRIES

Enquiries about corporate governance or other related matters (including enquiries to be put to the Board) should be directed to the Company Secretary by email at [company.secretary@nextteer.com](mailto:company.secretary@nextteer.com) or at the Company's headquarters address: 1272 Doris Road, Auburn Hills, Michigan 48326, USA.

Shareholders should direct their enquiries about their shareholdings to the Company's share registrar as follows:

By Mail: 17M Floor, Hopewell Centre  
183 Queen's Road East  
Wanchai, Hong Kong

Hong Kong Customer Service Phone: +852 2862 8555

Email: [hkinfo@computershare.com.hk](mailto:hkinfo@computershare.com.hk)

### SHAREHOLDERS' COMMUNICATION POLICY

The Company considers that effective communication with the Shareholders is essential for enhancing investor relations and understanding of the Group's business, performance and strategies. The Company also recognises the importance of timely and non-selective disclosure of information, which will enable Shareholders and investors to make the informed investment decisions.

To promote effective communication, the Company adopts and publishes on its website a shareholders' communication policy which sets out various communication channels for establishing a two-way relationship and communication between the Company and the Shareholders. The policy is reviewed on an annual basis to ensure its effectiveness. The Company maintains a website of the Company at <http://www.nextteer.com/>, where up-to-date information on the Company's business operations and developments, financial information, corporate governance practices and other information are available for public access.

The annual general meeting of the Company provides opportunity for the Shareholders to communicate directly with the Directors. The Chairman of the Company and the chairmen of the Board Committees of the Company will attend the AGMs to answer Shareholders' questions. The Auditor will also attend the AGMs to answer questions about the conduct of the audit, the preparation and content of the auditor's report, the accounting policies and auditor independence.

As such, the Company reviewed its shareholders engagement and communication activities conducted in 2022 and was satisfied with the implementation and effectiveness of its shareholders' communication policy.



## REMUNERATION OF DIRECTORS AND SENIOR MANAGEMENT

The Group has established a formal and transparent procedure for formulating policies on remuneration of Directors and Senior Management of the Group. Details of the remuneration of each of the Directors for the year ended December 31, 2022 are set out in note 24 to the Consolidated Financial Statements. The remuneration of Directors is determined by the Board, which receives recommendations from the Remuneration and Nomination Committee after considering the experience, knowledge and performance of the Directors. Under the Company's current compensation arrangements, the Executive Directors and Senior Management receive cash compensation in the form of salaries as well as bonuses that are subject to performance targets.

Remuneration paid to or accrued for the Senior Management (including two Executive Directors) for the year ended December 31, 2022 is within the following bands:

Band of remuneration in US\$	No. of person
US\$1 – US\$250,000	3
US\$250,001 – US\$500,000	2
US\$500,001 – US\$750,000	6
US\$750,001 – US\$1,000,000	2
US\$1,250,001 – US\$1,500,000	1
US\$1,500,001 – US\$1,750,000	1

## DIRECTORS' RESPONSIBILITY FOR THE FINANCIAL STATEMENTS

The Company has implemented a series of reports intended to allow the Board to assess the Group's financial and operational performance, as well as business results. On a monthly basis, management of the Group provides the Board with sufficient and adequate information to support its decision-making and oversight responsibilities.

The Board understands and acknowledges its responsibility for overseeing the preparation of the financial information in accordance with IFRS and for the internal control system necessary to enable the preparation of financial information that is free from material misstatement. This responsibility extends to annual and interim reports, other announcements and other financial disclosures required under the Listing Rules and/or statutory requirements. As at the date of this annual report, the Board is not aware of any material uncertainties relating to events or conditions that may cast significant doubt upon the Company's or the Group's ability to continue as a going concern.

The Company's external auditor is responsible for expressing an opinion on whether the Consolidated Financial Statements give a true and fair view of the state of affairs of the Group as at December 31, 2022, and of the Group's profit and cash flows for the year then ended in accordance with IFRS.

The auditor's statement about their reporting responsibilities on the Consolidated Financial Statements is set out in the section headed 'Independent Auditor's Report' of this annual report.

## RISK MANAGEMENT AND INTERNAL CONTROL

The Company has adopted a risk management and internal control system and associated procedures and conducts reviews of the effectiveness of the risk management and internal control system of the Group from time to time.

The responsibility for safeguarding the assets, for the prevention and detection of fraud and error, and for ensuring compliance with all applicable laws and regulations rests with the Board, the Audit and Compliance Committee and management of the Group. This responsibility includes implementing and ensuring the continued operation of the Group's risk management and internal control system which is designed to prevent and detect fraud and error.

## Corporate Governance Report

The Board is responsible for maintaining an adequate system of risk management and internal control and for reviewing its effectiveness. Oversight over risk management and internal control is led by the Audit and Compliance Committee. While Senior Management is responsible for the implementation of such system of risk management and internal control, the Group has established an Internal Audit department to assist the Board and the Audit and Compliance Committee in their oversight and review responsibilities to monitor the compliance and effectiveness of the risk management and internal control measures. This will enable the Board and the Audit and Compliance Committee to conduct necessary reviews and to report to shareholders, at least on an annual basis, on the effectiveness of the Group's system of risk management and internal control. The risk management and internal control system is designed to manage rather than eliminate the risk of failure to achieve business objectives, and only provide reasonable and not absolute assurance against material misstatement or loss.

The head of the Internal Audit department has direct access to the Board through direct communication to the Chairman of the Audit and Compliance Committee. The head of the Internal Audit department has the right to consult the Audit and Compliance Committee without reference to management. With this independence, the Internal Audit department is able to perform key tasks, such as: (a) assessing and monitoring compliance with policies and the effectiveness of risk management and internal control measures with unrestricted direct access to any level of management whenever deemed necessary; and (b) conducting comprehensive internal audits to evaluate the system of financial, operation and compliance controls on a regular basis.

The Internal Audit department has completed a risk assessment process and developed an Internal Audit plan that focuses on the key risks to the Company. The Company reviewed the risk assessment and Internal Audit plans with the Audit and Compliance Committee in 2022. The Internal Audit department executed the Internal Audit plan and conducted a review of the effectiveness of the system of risk management and internal control for key high risk frameworks. The Internal Audit department reported a summary of audit findings and recommendations to the Audit and Compliance Committee. Management is responsible for ensuring that identified control weaknesses are rectified within a reasonable period.

Management and the CFO, in conjunction with the Board and the Audit and Compliance Committee, continue to evaluate the adequacy of resources, qualifications and experience of staff in the Group's accounting and financial reporting and Internal Audit functions, as well as that function's training programmes and budget. This exercise continues to result in the hiring of accounting and finance professionals to help ensure that the Group maintains adequate and sufficient staffing levels required for a public company. The Board has delegated to the Audit and Compliance Committee the responsibility for reviewing the Group's system of risk management and internal control and reporting the findings to the Board. The Audit and Compliance Committee conducted a review of (1) the findings and recommendations of the Internal Audit function; (2) the implementation status of recommended internal control recommendations; and (3) the reports and findings from management on the implementation of the internal control measures. Based on its annual review, the Board and the Audit and Compliance Committee are not aware of any material deficiencies in the effectiveness of risk management and internal control for the year ended December 31, 2022 and consider them effective and adequate.

Management identifies, evaluates and manages significant risks to the Group. Management annually self-assesses the effectiveness of the risk management and internal control activities. The Group's risk management and internal control policies and procedures are designed and updated (as necessary) in consideration of jurisdictional regulations, customer requirements and industry practice. The Group has successfully redesigned and continues to operate under its Business System meeting the International Automotive Task Force (IATF) and customer requirements, as well as promoting and focusing on continual improvements to its business processes and practices.

## Corporate Governance Report

The risk management process facilitates the following sequence of activities and communication:

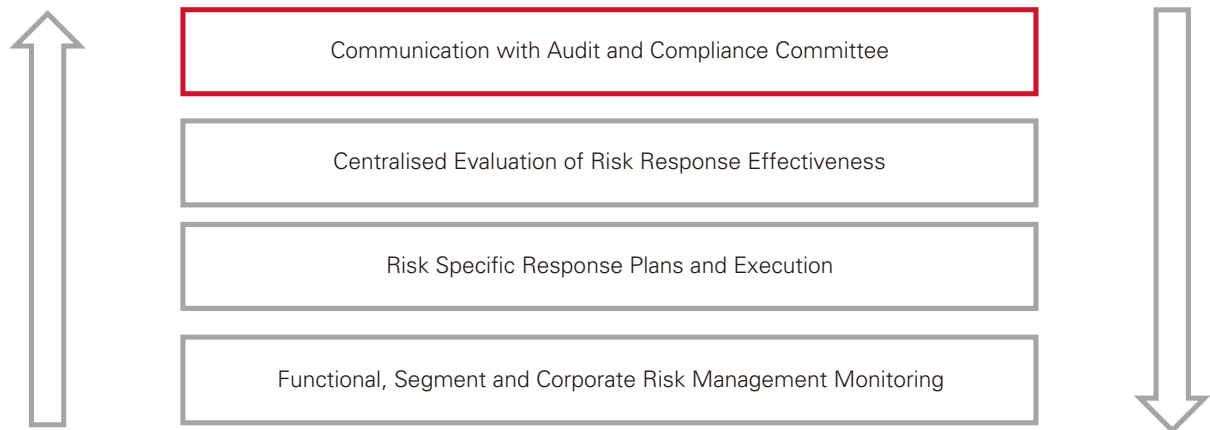

Risk management is a continuous process, occurring within functional departments, geographic segments and corporate oversight bodies. Management regularly assesses the nature, extent and magnitude of the identified risks and corresponding risk response plans. Management periodically evaluates the comparative significance of risk occurrence and consequences when considering risk response plans and associated plan effectiveness.

### **ANTI-CORRUPTION AND WHISTLEBLOWING POLICY AND SYSTEM**

The Group is committed to preventing incidents of bribery, extortion, fraud, and money laundering. We follow global policies that promote the highest ethical standards for behaviour and compliance with laws and regulations where we do business. For details, please refer to the section headed "Preventing Corruption" in the "2022 Sustainability Report".

### **CHANGE IN CONSTITUTIONAL DOCUMENTS**

There was no change in the Articles of Association of the Company for the year ended December 31, 2022.

## Independent Auditor's Report

# Deloitte.

# 德勤

### INDEPENDENT AUDITOR'S REPORT TO THE SHAREHOLDERS OF NEXTEER AUTOMOTIVE GROUP LIMITED *(incorporated in the Cayman Islands with limited liability)*

#### OPINION

We have audited the consolidated financial statements of Nexteer Automotive Group Limited (the "**Company**") and its subsidiaries (collectively referred to as the "**Group**") set out on pages 86 to 161, which comprise the consolidated balance sheet as at December 31, 2022, and the consolidated income statement, consolidated statement of comprehensive income, consolidated statement of changes in equity and consolidated statement of cash flows for the year then ended, and notes to the consolidated financial statements, including a summary of significant accounting policies.

In our opinion, the consolidated financial statements give a true and fair view of the consolidated financial position of the Group as at December 31, 2022, and of its consolidated financial performance and its consolidated cash flows for the year then ended in accordance with International Financial Reporting Standards ("**IFRSs**") issued by the International Accounting Standards Board ("**IASB**") and have been properly prepared in compliance with the disclosure requirements of the Hong Kong Companies Ordinance.

#### BASIS FOR OPINION

We conducted our audit in accordance with International Standards on Auditing ("**ISAs**") issued by the International Auditing and Assurance Standards Board ("**IAASB**"). Our responsibilities under those standards are further described in the Auditor's Responsibilities for the Audit of the Consolidated Financial Statements section of our report. We are independent of the Group in accordance with the International Ethics Standards Board for Accountants' International Code of Ethics for Professional Accountants (including International Independence Standards) (the "**Code**"), and we have fulfilled our other ethical responsibilities in accordance with the Code. We believe that the audit evidence we have obtained is sufficient and appropriate to provide a basis for our opinion.

#### KEY AUDIT MATTERS

Key audit matters are those matters that, in our professional judgment, were of most significance in our audit of the consolidated financial statements of the current period. These matters were addressed in the context of our audit of the consolidated financial statements as a whole, and in forming our opinion thereon, and we do not provide a separate opinion on these matters.

## Independent Auditor's Report

**Key Audit Matters****How our audit addressed the key audit matter****Capitalisation of product development costs**

Refer to notes 2.7(a), 4(a)(i) and 8 to the consolidated financial statements.

The Group incurs significant costs and efforts on research and development activities, which include costs to develop customer-specific applications, prototypes and testing. As disclosed in note 8 to the consolidated financial statements, capitalised product development costs within intangible assets as at December 31, 2022 amounted to US\$724.8 million and product development costs capitalised during the year ended December 31, 2022 amounted to US\$153.2 million.

Our audit was focused on this area given the significance of the development costs capitalised during the year ended December 31, 2022, as well as the complexity of the process used by management to account for these costs. Management uses significant judgement as part of this process including assessing whether costs are appropriately identified for capitalisation and that such costs are appropriately associated with programmes in the development phase of production in accordance with the capitalisation criteria as set out in note 2.7(a) to the consolidated financial statements. The key inputs utilised by management to calculate the development costs to be capitalised include labour hours and labour rates applied, as well as material costs.

We obtained understanding of the Group's process of capitalisation of product development costs and tested the design and implementation of relevant controls identified in this process.

We obtained an analysis prepared by management of all individual development projects costs capitalised in the period and agreed this analysis to the amounts recorded in the general ledger. We considered the product development cost components included in the analysis for capitalisation and assessed the determination for capitalisation of such costs by comparing the nature of the costs capitalised by management to the capitalisation criteria as set out in note 2.7(a) to the consolidated financial statements.

We also tested samples of projects as follows:

- We met with finance management, inquired of engineers, and reviewed programme documentation to determine whether the programmes had entered the development phase of the projects and whether the associated costs were thus eligible for capitalisation. We conducted interviews with individual project managers responsible for the projects selected to corroborate management's explanations and to obtain an understanding of the development phase of the specific projects. We also inspected agreements between the Group and their customers to support existence of the development programmes. These procedures enabled us to assess whether the projects would allow the underlying expenditure to meet the criteria for capitalisation as set out in note 2.7(a) to the consolidated financial statements.
- To determine whether costs were directly attributable to projects, we obtained detailed listings of hours worked on individual projects and selected samples of the employees' hours recorded. We obtained timesheets approved by the appropriate project managers to check that the employees selected for testing were involved on the projects and to evaluate the nature of the work they had been performing. We also recalculated the amount of costs capitalised for the projects selected, by applying a labour rate per employee to the timesheet hours.
- We also compared the labour rates, referred to above, that had been applied to the hours identified as appropriate for capitalisation to the employee costs within the general ledger.
- To test whether material costs were directly attributable to projects and capitalisable, we tested samples of capitalised material costs to assess whether the programmes to which they were being applied were in the development phase.

## Independent Auditor's Report

### OTHER INFORMATION

The directors of the Company are responsible for the other information. The other information comprises the information included in the annual report, but does not include the consolidated financial statements and our auditors report thereon.

Our opinion on the consolidated financial statements does not cover the other information and we do not express any form of assurance conclusion thereon.

In connection with our audit of the consolidated financial statements, our responsibility is to read the other information and, in doing so, consider whether the other information is materially inconsistent with the consolidated financial statements or our knowledge obtained in the audit or otherwise appears to be materially misstated. If, based on the work we have performed, we conclude that there is a material misstatement of this other information, we are required to report that fact. We have nothing to report in this regard.

### RESPONSIBILITIES OF DIRECTORS AND THOSE CHARGED WITH GOVERNANCE FOR THE CONSOLIDATED FINANCIAL STATEMENTS

The directors of the Company are responsible for the preparation of the consolidated financial statements that give a true and fair view in accordance with IFRSs issued by the IASB and the disclosure requirements of the Hong Kong Companies Ordinance, and for such internal control as the directors determine is necessary to enable the preparation of consolidated financial statements that are free from material misstatement, whether due to fraud or error.

In preparing the consolidated financial statements, the directors are responsible for assessing the Group's ability to continue as a going concern, disclosing, as applicable, matters related to going concern and using the going concern basis of accounting unless the directors either intend to liquidate the Group or to cease operations, or have no realistic alternative but to do so.

Those charged with governance are responsible for overseeing the Group's financial reporting process.

### AUDITOR'S RESPONSIBILITIES FOR THE AUDIT OF THE CONSOLIDATED FINANCIAL STATEMENTS

Our objectives are to obtain reasonable assurance about whether the consolidated financial statements as a whole are free from material misstatement, whether due to fraud or error, and to issue an auditor's report that includes our opinion solely to you, as a body, in accordance with our agreed terms of engagement, and for no other purpose. We do not assume responsibility towards or accept liability to any other person for the contents of this report. Reasonable assurance is a high level of assurance, but is not a guarantee that an audit conducted in accordance with ISAs will always detect a material misstatement when it exists. Misstatements can arise from fraud or error and are considered material if, individually or in the aggregate, they could reasonably be expected to influence the economic decisions of users taken on the basis of these consolidated financial statements.

As part of an audit in accordance with ISAs, we exercise professional judgment and maintain professional skepticism throughout the audit. We also:

- Identify and assess the risks of material misstatement of the consolidated financial statements, whether due to fraud or error, design and perform audit procedures responsive to those risks, and obtain audit evidence that is sufficient and appropriate to provide a basis for our opinion. The risk of not detecting a material misstatement resulting from fraud is higher than for one resulting from error, as fraud may involve collusion, forgery, intentional omissions, misrepresentations, or the override of internal control.

## Independent Auditor's Report

- Obtain an understanding of internal control relevant to the audit in order to design audit procedures that are appropriate in the circumstances, but not for the purpose of expressing an opinion on the effectiveness of the Group's internal control.
- Evaluate the appropriateness of accounting policies used and the reasonableness of accounting estimates and related disclosures made by the directors.
- Conclude on the appropriateness of the directors' use of the going concern basis of accounting and, based on the audit evidence obtained, whether a material uncertainty exists related to events or conditions that may cast significant doubt on the Group's ability to continue as a going concern. If we conclude that a material uncertainty exists, we are required to draw attention in our auditor's report to the related disclosures in the consolidated financial statements or, if such disclosures are inadequate, to modify our opinion. Our conclusions are based on the audit evidence obtained up to the date of our auditor's report. However, future events or conditions may cause the Group to cease to continue as a going concern.
- Evaluate the overall presentation, structure and content of the consolidated financial statements, including the disclosures, and whether the consolidated financial statements represent the underlying transactions and events in a manner that achieves fair presentation.
- Obtain sufficient appropriate audit evidence regarding the financial information of the entities or business activities within the Group to express an opinion on the consolidated financial statements. We are responsible for the direction, supervision and performance of the group audit. We remain solely responsible for our audit opinion.

We communicate with those charged with governance regarding, among other matters, the planned scope and timing of the audit and significant audit findings, including any significant deficiencies in internal control that we identify during our audit.

We also provide those charged with governance with a statement that we have complied with relevant ethical requirements regarding independence, and to communicate with them all relationships and other matters that may reasonably be thought to bear on our independence, and where applicable, actions taken to eliminate threats or safeguards applied.

From the matters communicated with those charged with governance, we determine those matters that were of most significance in the audit of the consolidated financial statements of the current period and are therefore the key audit matters. We describe these matters in our auditor's report unless law or regulation precludes public disclosure about the matter or when, in extremely rare circumstances, we determine that a matter should not be communicated in our report because the adverse consequences of doing so would reasonably be expected to outweigh the public interest benefits of such communication.

The engagement partner on the audit resulting in the independent auditor's report is Hung Suk Fan.

**Deloitte Touche Tohmatsu**  
*Certified Public Accountants*

Hong Kong  
March 15, 2023

# Consolidated Balance Sheet

As at December 31, 2022

	Notes	As at December 31,	
		2022 US\$'000	2021 US\$'000
<b>ASSETS</b>			
<b>Non-current assets</b>			
Property, plant and equipment	6	971,192	988,896
Right-of-use assets	7	62,146	63,389
Intangible assets	8	725,145	708,807
Deferred income tax assets	9	13,886	11,361
Investments in joint ventures	31b	23,395	22,904
Other receivables and prepayments	12	47,416	50,917
		<b>1,843,180</b>	1,846,274
<b>Current assets</b>			
Inventories	10	293,692	288,632
Trade receivables	11	803,168	626,078
Other receivables and prepayments	12	149,297	118,990
Restricted bank deposits	13	10	9
Cash and cash equivalents	14	245,934	326,516
		<b>1,492,101</b>	1,360,225
<b>Total assets</b>		<b>3,335,281</b>	3,206,499

The notes on pages 92 to 161 are an integral part of these Consolidated Financial Statements.



## Consolidated Balance Sheet

	Notes	As at December 31,	
		2022 US\$'000	2021 US\$'000
<b>EQUITY</b>			
<b>Capital and reserves attributable to equity holders of the Company</b>			
Share capital	33	32,377	32,377
Other reserves	15	(24,362)	33,893
Retained earnings		1,925,810	1,888,359
		<b>1,933,825</b>	1,954,629
<b>Non-controlling interests</b>		<b>43,325</b>	47,960
<b>Total equity</b>		<b>1,977,150</b>	2,002,589
<b>LIABILITIES</b>			
<b>Non-current liabilities</b>			
Lease liabilities	7	48,376	49,972
Borrowings	16	49,838	–
Retirement benefits and compensations	17	23,038	22,695
Deferred income tax liabilities	9	18,944	26,741
Provisions	18	71,006	60,608
Deferred revenue	19	104,613	86,737
Other payables and accruals	21	15,875	15,030
		<b>331,690</b>	261,783
<b>Current liabilities</b>			
Trade payables	20	815,402	666,501
Other payables and accruals	21	134,523	120,408
Current income tax liabilities		12,928	13,733
Retirement benefits and compensations	17	4,132	3,613
Provisions	18	22,721	17,388
Deferred revenue	19	24,240	23,691
Lease liabilities	7	12,495	12,390
Borrowings	16	–	84,403
		<b>1,026,441</b>	942,127
<b>Total liabilities</b>		<b>1,358,131</b>	1,203,910
<b>Total equity and liabilities</b>		<b>3,335,281</b>	3,206,499

The notes on pages 92 to 161 are an integral part of these Consolidated Financial Statements.

The Consolidated Financial Statements on pages 86 to 161 were approved by the Board of Directors on March 15, 2023 and were signed on its behalf.

LEI, Zili

Director

MILAVEC, Robin Zane

Director

# Consolidated Income Statement

For the year ended December 31, 2022

	Notes	For the year ended December 31,	
		2022 US\$'000	2021 US\$'000
<b>Revenue</b>	5	<b>3,839,703</b>	3,358,725
Cost of sales	23	<b>(3,472,552)</b>	(2,995,296)
<b>Gross profit</b>		<b>367,151</b>	363,429
Engineering and product development costs	23	<b>(145,080)</b>	(116,299)
Selling and distribution expenses	23	<b>(18,250)</b>	(17,662)
Administrative expenses	23	<b>(132,474)</b>	(131,391)
Other gains, net	22	<b>14,974</b>	17,138
<b>Operating profit</b>		<b>86,321</b>	115,215
Finance income	25	<b>8,651</b>	4,426
Finance costs	25	<b>(3,655)</b>	(6,281)
Share of results of joint ventures	25 31b	<b>4,996</b> <b>630</b>	(1,855) 653
<b>Profit before income tax</b>		<b>91,947</b>	114,013
Income tax (expense) benefit	26	<b>(26,434)</b>	12,390
<b>Profit for the year</b>		<b>65,513</b>	126,403
<b>Profit for the year attributable to:</b>			
Equity holders of the Company		<b>58,013</b>	118,440
Non-controlling interests		<b>7,500</b>	7,963
		<b>65,513</b>	126,403
<b>Earnings per share for profit for the year attributable to equity holders of the Company (expressed in US\$ per share)</b>			
– Basic and diluted	27	<b>US\$0.02</b>	US\$0.05

The notes on pages 92 to 161 are an integral part of these Consolidated Financial Statements.

# Consolidated Statement of Comprehensive Income

For the year ended December 31, 2022

	For the year ended December 31,	
	2022 US\$'000	2021 US\$'000
<b>Profit for the year</b>	<b>65,513</b>	126,403
<b>Other comprehensive loss</b>		
<b><i>Item that will not be reclassified to profit or loss</i></b>		
Actuarial gains on defined benefit plans, net of tax of US\$530,000 (2021: US\$452,000)	<b>1,639</b>	1,452
<b><i>Item that may be reclassified subsequently to profit or loss</i></b>		
Exchange differences	<b>(61,086)</b>	(24,525)
	<b>(59,447)</b>	(23,073)
<b>Total comprehensive income for the year</b>	<b>6,066</b>	103,330
<b>Total comprehensive income for the year attributable to:</b>		
Equity holders of the Company	<b>2,904</b>	94,353
Non-controlling interests	<b>3,162</b>	8,977
	<b>6,066</b>	103,330

The notes on pages 92 to 161 are an integral part of these Consolidated Financial Statements.

# Consolidated Statement of Changes in Equity

For the year ended December 31, 2022

	Attributable to equity holders of the Company							Non-controlling interests US\$'000	Total US\$'000
	Share capital US\$'000	Share premium US\$'000 (note 15)	Merger reserve US\$'000 (note 15)	Share-based compensation reserve US\$'000 (note 15)	Exchange reserve US\$'000 (note 15)	Retained earnings US\$'000	Sub-total US\$'000		
As at January 1, 2021	32,347	-	113,000	6,923	(61,271)	1,791,003	1,882,002	38,983	1,920,985
<b>Comprehensive income</b>									
Profit for the year	-	-	-	-	-	118,440	118,440	7,963	126,403
<b>Other comprehensive (loss) income</b>									
Exchange differences	-	-	-	-	(25,539)	-	(25,539)	1,014	(24,525)
Actuarial gains on defined benefit plans, net of tax	-	-	-	-	-	1,452	1,452	-	1,452
<b>Total other comprehensive (loss) income</b>	-	-	-	-	(25,539)	1,452	(24,087)	1,014	(23,073)
<b>Total comprehensive (loss) income</b>	-	-	-	-	(25,539)	119,892	94,353	8,977	103,330
<b>Transactions with owners</b>									
Value of employee services provided under Share Option Scheme (note 24(a))	-	-	-	21	-	-	21	-	21
Transfer to share premium under exercise of share options	-	883	-	(883)	-	-	-	-	-
Proceeds from exercise of share options	30	1,804	-	-	-	-	1,834	-	1,834
Dividends paid to shareholders	-	(1,045)	-	-	-	(22,536)	(23,581)	-	(23,581)
Total transactions with owners	30	1,642	-	(862)	-	(22,536)	(21,726)	-	(21,726)
<b>As at December 31, 2021</b>	<b>32,377</b>	<b>1,642</b>	<b>113,000</b>	<b>6,061</b>	<b>(86,810)</b>	<b>1,888,359</b>	<b>1,954,629</b>	<b>47,960</b>	<b>2,002,589</b>
<b>Comprehensive income</b>									
Profit for the year	-	-	-	-	-	58,013	58,013	7,500	65,513
<b>Other comprehensive (loss) income</b>									
Exchange differences	-	-	-	-	(56,748)	-	(56,748)	(4,338)	(61,086)
Actuarial gains on defined benefit plans, net of tax	-	-	-	-	-	1,639	1,639	-	1,639
<b>Total other comprehensive (loss) income</b>	-	-	-	-	(56,748)	1,639	(55,109)	(4,338)	(59,447)
<b>Total comprehensive (loss) income</b>	-	-	-	-	(56,748)	59,652	2,904	3,162	6,066
<b>Transactions with owners</b>									
Value of employee services provided under Share Option Scheme (note 24(a))	-	-	-	135	-	-	135	-	135
Dividends paid to shareholders	-	(1,642)	-	-	-	(22,201)	(23,843)	-	(23,843)
Dividends paid to non-controlling interests	-	-	-	-	-	-	-	(7,797)	(7,797)
Total transactions with owners	-	(1,642)	-	135	-	(22,201)	(23,708)	(7,797)	(31,505)
<b>As at December 31, 2022</b>	<b>32,377</b>	<b>-</b>	<b>113,000</b>	<b>6,196</b>	<b>(143,558)</b>	<b>1,925,810</b>	<b>1,933,825</b>	<b>43,325</b>	<b>1,977,150</b>

The notes on pages 92 to 161 are an integral part of these Consolidated Financial Statements.

# Consolidated Statement of Cash Flows

For the year ended December 31, 2022

	Notes	For the year ended December 31,	
		2022 US\$'000	2021 US\$'000
<b>Operating activities</b>			
Cash generated from operations	29(a)	<b>335,682</b>	318,897
Income tax paid, net		<b>(41,926)</b>	(31,514)
Net cash generated from operating activities		<b>293,756</b>	287,383
<b>Investing activities</b>			
Purchase of property, plant and equipment		<b>(120,343)</b>	(141,601)
Addition of intangible assets		<b>(146,380)</b>	(146,679)
Others		<b>3,249</b>	2,616
Net cash used in investing activities		<b>(263,474)</b>	(285,664)
<b>Financing activities</b>			
Proceeds from borrowings	29(b)	<b>178,050</b>	144,144
Repayments of borrowings	29(b)	<b>(207,562)</b>	(308,642)
Repayments of lease liabilities	29(b)	<b>(14,401)</b>	(13,709)
Finance costs paid		<b>(9,627)</b>	(15,494)
Dividends paid to equity holders of the Company		<b>(23,843)</b>	(23,581)
Dividends paid to non-controlling interests		<b>(7,797)</b>	–
Proceeds from exercise of share options		–	1,834
Net cash used in financing activities		<b>(85,180)</b>	(215,448)
<b>Net decrease in cash and cash equivalents</b>		<b>(54,898)</b>	(213,729)
Cash and cash equivalents at beginning of year		<b>326,516</b>	553,424
Effect of exchange rate changes on cash and cash equivalents		<b>(25,684)</b>	(13,179)
<b>Cash and cash equivalents at end of year</b>		<b>245,934</b>	326,516

The notes on pages 92 to 161 are an integral part of these Consolidated Financial Statements.

# Notes to the Consolidated Financial Statements

For the year ended December 31, 2022

## 1 GENERAL INFORMATION

Nexteer Automotive Group Limited (the **Company**) was incorporated in the Cayman Islands on August 21, 2012 as an exempted company with limited liability under Companies Law (as amended), of the Cayman Islands. The address of the Company's registered office is P.O. Box 309, Ugland House, Grand Cayman, KY1-1104, Cayman Islands.

The Company is an investment holding company. The Company, together with its subsidiaries (collectively referred to as the **Group**), are principally engaged in the design and manufacture of steering and driveline systems, Advanced Driver Assistance Systems (**ADAS**) and Automated Driving (**AD**) and components for automobile manufacturers and other automotive-related companies. The Group's primary operations are in the United States of America (**USA** or **US**), Mexico, the People's Republic of China (**China**), Poland, India, Morocco and Brazil and are structured to supply its customers globally. The principal markets for the Group's products are North America, Europe, South America, China and India.

The Company's directors regard Aviation Industry Corporation of China, Ltd. (**AVIC**), a company established in China, as being the ultimate holding company of the Company. The Company's immediate holding company is Nexteer Automotive (Hong Kong) Holdings Limited.

The Company's shares have been listed on the Main Board of The Stock Exchange of Hong Kong Limited since October 7, 2013 (the **Listing**).

These consolidated financial statements (the **Consolidated Financial Statements**) are presented in thousands of US dollars (**US\$'000**), unless otherwise stated. The Consolidated Financial Statements were approved by the Board of Directors of the Company (the **Board**) for issue on March 15, 2023.

## 2 SUMMARY OF SIGNIFICANT ACCOUNTING POLICIES

The principal accounting policies applied in the preparation of these Consolidated Financial Statements are set out below. These policies have been consistently applied to all the years presented, unless otherwise stated.

### 2.1 Basis of preparation

The Consolidated Financial Statements have been prepared in accordance with International Financial Reporting Standards (**IFRS**) as issued by the International Accounting Standards Board. In addition, the Consolidated Financial Statements include applicable disclosures required by the Rules Governing the Listing of Securities on The Stock Exchange of Hong Kong Limited and by the Hong Kong Companies Ordinance. The Consolidated Financial Statements have been prepared under the historical cost convention except for notes receivable that are measured at fair value.

The preparation of financial statements in conformity with IFRS requires the use of certain critical accounting estimates. It also requires management to exercise its judgement in the process of applying the Group's accounting policies. The areas involving a higher degree of judgement or complexity, or areas where assumptions and estimates are significant to the Consolidated Financial Statements are disclosed in note 4.

## Notes to the Consolidated Financial Statements

**2 SUMMARY OF SIGNIFICANT ACCOUNTING POLICIES (Continued)****2.1 Basis of preparation (Continued)***COVID-19 Update*

The global automotive industry continued to be impacted by the COVID-19 pandemic throughout 2022, particularly a result of supply shortages as OEM production demand continued to recover. The most significant supply shortage relates to semiconductor chips, which is impacting global industry production, and resulting in significant cancellations of planned OEM production. Supply shortages and the on-going volatility in OEM production schedules adversely impacted our manufacturing and material efficiencies in 2022. In addition, increases in certain commodity and logistics costs had an adverse impact on our operating results for the year ended December 31, 2022. It is possible a resurgence of the COVID-19 pandemic could result in adverse impacts in the future. Management cannot reasonably estimate the full impact the COVID-19 pandemic could have on the Group's financial condition, results of operations or cash flows in the future.

The Group assessed certain accounting matters that require consideration of forecasted financial information, including, but not limited to, its allowance for credit losses, the carrying value of the Group's intangible assets and other long-lived assets in context with the information reasonably available to the Group and the unknown future impacts of COVID-19 as at December 31, 2022 and through the date of this report. As a result of these assessments, there were no material increases in credit allowances that impacted the Group's Consolidated Financial Statements as at and for the year ended December 31, 2022. However, the Group's future assessment of the magnitude and duration of COVID-19, as well as other factors, could result in material impacts to the Consolidated Financial Statements in future reporting periods. The Group recorded impairments to product development intangible assets for the year ended December 31, 2022, as set out in note 8.

Given the ever-changing and uncertain worldwide situation regarding COVID-19 and its potential further impacts on the economies of afflicted regions, and the inherent difficulty in predicting potential further impact on the Group's facilities, employees, customers, suppliers and logistics providers, the Group has made assumptions based on best available information but due to the uncertainties related to COVID-19 the actual results may be materially different than the current assumptions used by management.

**2.2 Subsidiaries***(a) Consolidation*

Subsidiaries are all entities over which the Group has control. The Group controls an entity where the Group is exposed to, or has rights to, variable returns from its involvement with the entity and has the ability to affect those returns through its power to direct the activities of the entity. Subsidiaries are fully consolidated from the date on which control is transferred to the Group and are deconsolidated from the date that control ceases. Upon consolidation, intercompany transactions, balances, income and expenses on transactions between group companies are eliminated. Profits and losses resulting from intercompany transactions that are recognised in assets are also eliminated.

## Notes to the Consolidated Financial Statements

**2 SUMMARY OF SIGNIFICANT ACCOUNTING POLICIES** (Continued)**2.2 Subsidiaries** (Continued)*(b) Separate financial statements*

Investments in subsidiaries are accounted for at cost less impairment. Cost also includes direct attributable costs of investment. The results of subsidiaries are accounted for by the Company on the basis of dividends received and receivable.

Impairment testing of the investments in subsidiaries is required when there is indication that the investments may be impaired. Impairment indicators may include receiving dividends in an amount that exceeds the total comprehensive income of the subsidiary in the period the dividend is declared or if the carrying amount of the investment in the separate financial statements exceeds the carrying amount in the Consolidated Financial Statements of the subsidiary's net assets including goodwill.

**2.3 Joint arrangements**

Joint arrangements are classified as either joint operations or joint ventures, depending on the contractual rights and obligations of each investor. The Group has assessed the nature of its joint arrangements and accounts for these as joint ventures using the equity method of accounting.

Under the equity method of accounting, interests in joint ventures are initially recognised at cost and adjusted thereafter to recognise the Group's share of the post-acquisition profits or losses and movements in other comprehensive income. When the Group's share of losses in a joint venture equals or exceeds its interests in the joint ventures (which includes any long-term interests that, in substance, form part of the Group's net investment in the joint venture), the Group does not recognise further losses, unless it has incurred obligations or made payments on behalf of the joint ventures. Any distributions the Group receives from the joint ventures reduce the carrying amount of the investment.

Unrealised gains on transactions between the Group and its joint ventures are eliminated to the extent of the Group's interests in the joint ventures. Unrealised losses are also eliminated unless the transaction provides evidence of an impairment of the asset transferred. Accounting policies of the joint ventures have been aligned where necessary to ensure consistency with the policies adopted by the Group.



## Notes to the Consolidated Financial Statements

**2 SUMMARY OF SIGNIFICANT ACCOUNTING POLICIES** (Continued)**2.4 Segment reporting**

Operating segments are reported in a manner consistent with the internal reporting to the chief operating decision maker who has been identified as the Chief Executive Officer (**CEO**). The CEO is responsible for resource allocation and assessing the performance of the operating segments.

**2.5 Foreign currency translation***(a) Functional and presentation currency*

Items included in the financial statements of each of the Group's entities are measured using functional currency in accordance with IAS 21, 'The Effects of Changes in Foreign Exchange Rates'. The Consolidated Financial Statements are presented in US dollars, which is the Company's functional currency and the Group's presentation currency.

*(b) Transactions and balances*

Foreign currency transactions are translated into the functional currency using the exchange rates prevailing at the dates of the transactions or valuation where items are re-measured. Foreign exchange gains and losses resulting from the settlement of such transactions and from the translation at year-end exchange rates of monetary assets and liabilities denominated in foreign currencies are recognised in the consolidated income statement.

*(c) Group companies*

The results of operations and financial position of all the group entities that have a functional currency different from the presentation currency are translated into the presentation currency as follows:

- (i) Assets and liabilities for each balance sheet presented are translated at the closing rate at the date of that balance sheet;
- (ii) Income and expenses for each income statement are translated at average exchange rates (unless this average is not a reasonable approximation of the cumulative effect of the rates prevailing on the transaction dates, in which case income and expenses are translated at the rate on the dates of the related transactions); and
- (iii) All resulting exchange differences are recognised in other comprehensive income and loss.

## Notes to the Consolidated Financial Statements

**2 SUMMARY OF SIGNIFICANT ACCOUNTING POLICIES** (Continued)**2.6 Property, plant and equipment**

Items of property, plant and equipment (including tools but excluding construction-in-progress) are measured at cost less accumulated depreciation and accumulated impairment losses. Improvements that materially extend the useful life of these assets are capitalised. When parts of an item of property, plant and equipment have different useful lives, they are accounted for as separate items (major components) of property, plant and equipment.

Subsequent costs are included in the asset's carrying amount or as a separate asset, as appropriate, only when it is probable that future economic benefits associated with the item will flow to the Group and the cost of the item can be measured reliably. The carrying amount of the replaced part is derecognised. All other repairs and maintenance are charged to the consolidated income statement during the financial period in which they are incurred.

Freehold land is not depreciated. Depreciation on items of property, plant and equipment is calculated using the straight-line basis to allocate their cost to their residual values over their estimated useful lives as follows:

Land improvements	3-20 years
Leasehold improvements	6-18 years or over lease term, whichever is shorter
Buildings	20-40 years
Machinery, equipment and tooling	3-20 years
Furniture and office equipment	3-18 years

Tooling represents tools, dies, jigs and other items used in the manufacturing of customer-specific parts. Tools owned by the Group are capitalised as property, plant and equipment and depreciated to cost of sales over their useful lives.

The assets' residual values and useful lives are reviewed annually and adjusted if appropriate.

An asset's carrying amount is written down immediately to its recoverable amount if the asset's carrying amount is greater than its estimated recoverable amount (note 2.8).

Gains and losses on disposal are determined by comparing the proceeds with the carrying amount and are recognised within other gains, net in the Consolidated Financial Statements.

Construction-in-progress represents leasehold improvements, buildings, machinery and equipment under construction or pending installation and is stated at cost less accumulated impairment losses. Cost includes the costs of construction, installation, testing and other direct costs, and capitalised interest. Sale proceeds of items that are produced while bringing an item of property, plant and equipment to the location and condition necessary for it to be capable of operating in the manner intended by management (such as samples produced when testing whether the asset is functioning properly), and the related costs of producing those items are recognised in the profit or loss. The cost of those items are measured in accordance with the measurement requirements of IAS 2 'Inventories'. No provision for depreciation is made on construction-in-progress until such time as the relevant assets are completed and ready for intended use.

## Notes to the Consolidated Financial Statements

**2 SUMMARY OF SIGNIFICANT ACCOUNTING POLICIES** (Continued)**2.7 Intangible assets***(a) Research and development*

The Group incurs significant costs and effort on research and development activities, which include expenditures on customer-specific applications, prototypes and testing. Research expenditures are charged to the consolidated income statement as an expense in the period the expenditure is incurred. Development costs are recognised as assets if they can be clearly assigned to a newly developed product or process and all the following can be demonstrated:

- (i) The technical feasibility to complete the development project so that it will be available for use or sale;
- (ii) The intention to complete the development project to use it;
- (iii) The ability to use the output of the development project;
- (iv) The manner in which the development project will generate probable future economic benefits for the Group;
- (v) The availability of adequate technical, financial and other resources to complete the development project and use or sell the intangible asset; and
- (vi) The expenditure attributable to the asset during its development can be reliably measured.

The cost of an internally generated intangible asset is the sum of the expenditure incurred from the date the asset meets the recognition criteria above to the date when it is available for use. The costs capitalised in connection with the intangible asset include costs of materials and services used or consumed and employee costs incurred in the creation of the asset. Development expenditures not satisfying the above criteria are recognised in the consolidated income statement as incurred.

Capitalised development costs are amortised using the straight-line method over the life of the related production programme, usually four to eight years.

*(b) Computer software*

Costs associated with maintaining computer software programmes are recognised as an expense as incurred. Development costs that are directly attributable to the design and testing of identifiable and unique software products controlled by the Group are recognised as intangible assets when the following criteria are met:

- (i) It is technically feasible to complete the software product and use it;
- (ii) Management intends to complete the software product and use it;
- (iii) There is an ability to use the software product;
- (iv) It can be demonstrated how the software product will generate probable future economic benefits;
- (v) Adequate technical, financial and other resources to complete the development and to use the software product are available; and

## Notes to the Consolidated Financial Statements

**2 SUMMARY OF SIGNIFICANT ACCOUNTING POLICIES** (Continued)**2.7 Intangible assets** (Continued)*(b) Computer software* (Continued)

- (vi) The expenditure attributable to the software product during its development can be reliably measured.

Directly attributable costs that are capitalised as part of the software product include the software development employee costs and an appropriate portion of relevant overhead costs.

Development costs not satisfying the above criteria are recognised as an expense as incurred. Development costs previously recognised as an expense are not recognised as an asset in the subsequent period.

Computer software development costs recognised as assets are amortised using the straight-line method over their estimated useful lives, which does not exceed five years.

**2.8 Impairment of non-financial assets**

Intangible development assets not ready to use are not subject to amortisation and are tested annually for impairment and whenever there is an indication of impairment. Assets that are subject to depreciation/amortisation are reviewed for impairment whenever events or changes in circumstances indicate that the carrying amount may not be recoverable. An impairment loss is recognised for the amount by which the asset's carrying amount exceeds its recoverable amount. The recoverable amount is the higher of an asset's fair value less costs to sell and value in use. For the purposes of assessing impairment, assets are tested for impairment individually. When it is not possible to estimate the recoverable amount individually, assets are grouped at the lowest levels for which there are separately identifiable cash flows (**cash-generating units**). Non-financial assets that suffered an impairment are reviewed for possible reversal of the impairment at each reporting date.

In testing a cash-generating unit for impairment, corporate assets are allocated to the relevant cash-generating unit when a reasonable and consistent basis of allocation can be established, or otherwise they are allocated to the smallest group of cash-generating units for which a reasonable and consistent allocation basis can be established. The recoverable amount is determined for the cash-generating unit or group of cash-generating units to which the corporate asset belongs, and is compared with the carrying amount of the relevant cash-generating unit or group of cash-generating units.

**2.9 Financial assets***(a) Classification*

The Group's financial assets primarily comprise cash and cash equivalents, restricted bank deposits, trade receivables, notes receivable and other receivables.

Financial assets are included in current assets, except for the amounts that are expected to be realised beyond the Group's normal operating cycle, or that are expected to be settled more than 12 months after the end of the reporting period. These are classified as non-current assets.

## Notes to the Consolidated Financial Statements

**2 SUMMARY OF SIGNIFICANT ACCOUNTING POLICIES** (Continued)**2.9 Financial assets** (Continued)*(b) Recognition and measurement*

Financial assets are recognised when the Group becomes a party to the contractual provisions of the instrument. Regular way purchases and sales of financial assets are recognised on the trade-date – the date on which the Group commits to purchase or sell the asset. Financial assets are initially recognised at fair value plus transaction costs for all financial assets not carried at fair value through profit or loss (other than trade receivables arising from contracts with customers which are initially measured in accordance with IFRS 15 'Revenue from Contracts with Customers'). Financial assets carried at fair value through profit or loss are initially recognised at fair value, and transaction costs are expensed in the consolidated income statement.

The Group classifies its financial assets in the following subsequent measurement categories:

- those to be measured subsequently at fair value (either through other comprehensive income or through profit or loss), and
- those to be subsequently measured at amortised cost.

The classification depends on the entity's business model for managing the financial assets and the contractual terms of the cash flows.

Subsequent measurement of financial assets depends on the Group's business model for managing the asset and the cash flow characteristics of the asset. Assets that are held for collection of contractual cash flows where those cash flows represent solely payments of principal and interest are measured at amortised cost. Interest income from these financial assets is included in finance income using the effective interest method. Any gain or loss arising on derecognition is recognised directly in profit or loss and presented in other gains, net together with foreign exchange gains and losses.

Financial assets that are held within a business model whose objective is achieved by both selling and collecting contractual cash flows and have contractual terms that give rise on specified dates to cash flows that are solely payments of principal and interest on the principal amount outstanding are subsequently measured at fair value through other comprehensive income (**FVOCI**). Subsequent changes in the carrying amounts of financial assets classified as FVOCI as a result of interest income calculated using the effective interest method and foreign exchange gains and losses are recognised in profit or loss. All other changes in the carrying amount of these financial assets are recognised in other comprehensive income. When these financial assets are derecognised, the cumulative gains or losses previously recognised in other comprehensive income are reclassified to profit or loss.

The Group's notes receivable are measured at FVOCI and all other financial assets are measured at amortised cost.

*(c) Impairment of financial assets*

On a forward-looking basis, the Group assesses the expected credit losses associated with its financial assets carried at amortised cost and at FVOCI. The impairment methodology applied depends on whether there has been a significant increase in credit risk. For trade receivables, the Group applies the simplified approach required by IFRS 9 'Financial Instruments' (**IFRS 9**), which requires lifetime expected credit losses to be recognised from initial recognition of these trade receivables. For other financial assets at amortised cost, the Group recognises a loss allowance equal to 12-month expected credit losses unless there has been a significant increase in credit risk of the financial assets since initial recognition, in which case the loss allowance is measured at an amount equal to lifetime expected credit losses. For notes receivable measured at FVOCI, impairment allowances are recognised in profit or loss with corresponding adjustment to other comprehensive income without reducing the carrying amounts of notes receivable.

## Notes to the Consolidated Financial Statements

**2 SUMMARY OF SIGNIFICANT ACCOUNTING POLICIES** (Continued)**2.9 Financial assets** (Continued)*(c) Impairment of financial assets* (Continued)

In assessing whether the credit risk has increased significantly since initial recognition, the Group compares the risk of a default occurring on the financial instrument as at the reporting date with the risk of a default occurring on the financial instrument as at the date of initial recognition. In making this assessment, the Group considers both quantitative and qualitative information that is reasonable and supportable, including historical experience and forward-looking information that is available without undue cost or effort.

In particular, the following information is taken into account when assessing whether credit risk has increased significantly:

- an actual or expected significant deterioration in the financial instrument's external (if available) or internal credit rating;
- significant deterioration in external market indicators of credit risk, e.g. a significant increase in the credit spread, the credit default swap prices for the debtor;
- existing or forecast adverse changes in business, financial or economic conditions that are expected to cause a significant decrease in the debtor's ability to meet its debt obligations;
- an actual or expected significant deterioration in the operating results of the debtor;
- an actual or expected significant adverse change in the regulatory, economic or technological environment of the debtor that results in a significant decrease in the debtor's ability to meet its debt obligations.

Irrespective of the outcome of the above assessment, the Group presumes that the credit risk has increased significantly since initial recognition when contractual payments are more than 30 days past due, unless the Group has reasonable and supportable information that demonstrates otherwise.

The Group regularly monitors the effectiveness of the criteria used to identify whether there has been a significant increase in credit risk and revises them as appropriate to ensure that the criteria are capable of identifying significant increase in credit risk before the amount becomes past due.

For internal credit risk management, the Group considers an event of default occurs when information developed internally or obtained from external sources indicates that the debtor is unlikely to pay its creditors, including the Group, in full (without taking into account any collaterals held by the Group). Irrespective of the above, the Group considers that default has occurred when a financial asset is more than 90 days past due unless the Group has reasonable and supportable information to demonstrate that a more lagging default criterion is more appropriate.

The Group writes off a financial asset when there is no reasonable expectation of recovery. A write-off constitutes a derecognition event. Any subsequent recoveries are recognised in profit or loss.

## 2 SUMMARY OF SIGNIFICANT ACCOUNTING POLICIES (Continued)

### 2.9 Financial assets (Continued)

#### (d) Derecognition of financial assets

The Group derecognises a financial asset only when the contractual rights to the cash flows from the assets expire, or when it transfers the financial asset or substantially all the risks and rewards of ownership of the asset to another entity. On derecognition of a financial asset measured at amortised cost, the difference between the asset's carrying amount and the sum of the consideration received and receivable is recognised in profit or loss. On derecognition of notes receivable classified as FVOCI, the cumulative gain or loss previously accumulated in other comprehensive income is reclassified to profit or loss.

### 2.10 Inventories

Inventories are stated at the lower of cost and net realisable value. Cost is determined using the first-in, first-out method. Inventory cost includes direct material, direct labour and related manufacturing overhead costs (based on normal operating capacity). Net realisable value is the estimated selling price in the ordinary course of business, less all estimated costs of completion and costs necessary to make the sale. Costs necessary to make the sale include incremental costs directly attributable to the sale and non-incremental costs which the Group must incur to make the sale.

### 2.11 Trade receivables and other receivables and prepayments

Trade receivables are amounts due from customers for merchandise sold or services performed in the ordinary course of business. If collection of trade and other receivables is expected in one year or less (or in the normal operating cycle of the business if longer), they are classified as current assets. If not, they are presented as non-current assets.

### 2.12 Cash and cash equivalents

Cash and cash equivalents presented on the consolidated balance sheet include:

- cash, which comprises of cash on hand and demand deposits, excluding bank balances that are subject to regulatory restrictions that result in such balances no longer meeting the definition of cash; and
- cash equivalents, which comprises of short-term (generally with original maturity of three months or less), highly liquid investments that are readily convertible to a known amount of cash and which are subject to an insignificant risk of changes in value. Cash equivalents are held for the purpose of meeting short-term cash commitments rather than for investment or other purposes.

For the purposes of the consolidated statement of cash flows, cash and cash equivalents consist of cash and cash equivalents as defined above.

### 2.13 Share capital

Ordinary shares are classified as equity. Incremental costs directly attributable to the issue of new shares are included in equity as a deduction from the proceeds.

### 2.14 Financial liabilities

Financial liabilities are recognised when the Group becomes a party to the contractual provisions of the instrument. Financial liabilities are initially measured at fair value. Transaction costs directly attributable to the issue of financial liabilities are deducted from the fair value of the financial liabilities on initial recognition.

The Group's financial liabilities are subsequently measured at amortised cost using the effective interest method.

The Group derecognises financial liabilities when, and only when, the Group's obligations are discharged, cancelled or have expired. The difference between the carrying amount of the financial liability derecognised and the consideration paid and payable is recognised in profit or loss.

## Notes to the Consolidated Financial Statements

**2 SUMMARY OF SIGNIFICANT ACCOUNTING POLICIES** (Continued)**2.15 Borrowings**

Borrowings are recognised initially at fair value, net of transaction costs incurred. Borrowings are subsequently carried at amortised cost; any difference between the proceeds (net of transaction costs) and the redemption value is recognised in the Consolidated Financial Statements as finance costs over the period of the borrowings using the effective interest method.

Borrowings are classified as current liabilities unless the Group has an unconditional right to defer settlement of the liability for at least 12 months after the reporting period.

**2.16 Borrowing costs**

General and specific borrowing costs directly attributable to the acquisition, construction or production of qualifying assets, which are assets that necessarily take a substantial period of time to get ready for their intended use or sale, are added to the cost of those assets, until such time as the assets are substantially ready for their intended use or sale.

The capitalisation rate is the weighted average of the borrowing costs applicable to the borrowings outstanding during the period up to the amount of actual borrowing costs incurred during that period. Any specific borrowing that remains outstanding after the related asset is ready for its intended use or sale is included in the general borrowing pool for calculation of capitalisation rate on general borrowings. Investment income earned on the temporary investment of specific borrowings pending their expenditure on qualifying assets is deducted from the borrowing costs eligible for capitalisation. All other borrowing costs are recognised in profit or loss in the period in which they are incurred.

**2.17 Retirement obligations**

The Group has both defined contribution and defined benefit plans. Group companies operate various pension schemes. The schemes are generally funded through payments to insurance companies or trustee-administered funds, as determined by periodic actuarial calculations.

*(a) Defined contribution plans*

A defined contribution plan is a pension plan under which the Group pays contributions into a separate entity. The Group has no legal or constructive obligations to pay further contributions if the fund does not hold sufficient assets to pay all employees the benefits relating to prior or current employee services.

The Group pays contributions to, including but not limited to, publicly or privately administered pension insurance plans on a mandatory or voluntary basis. The Group has no further payment obligations once the contributions have been paid. The contributions are recognised as employee benefit expense when they are due. Prepaid contributions are recognised as an asset to the extent that a cash refund or a reduction in the future payments is available.



## 2 SUMMARY OF SIGNIFICANT ACCOUNTING POLICIES (Continued)

### 2.17 Retirement obligations (Continued)

#### (b) Defined benefit plans

A defined benefit plan is a pension plan that is not a defined contribution plan. Typically, defined benefit plans define an amount of pension benefit that an employee will receive upon retirement, usually dependent on one or more factors such as age, years of service and compensation.

The liability recognised in the Consolidated Financial Statements in respect of defined benefit pension plans is the present value of the defined benefit obligation at the end of the reporting period less the fair value of plan assets. The defined benefit obligation is calculated annually by independent actuaries using the projected unit credit method. The salary level trend refers to the expected rate of salary increase, which is estimated annually depending on inflation and the career development of employees within the Group. The present value of the defined benefit obligation is determined by discounting the estimated future cash outflows using interest rates of high-quality corporate bonds that are denominated in the currency in which the benefits will be paid and that have terms to maturity approximating the terms of the related pension obligation. A company-specific default risk is not taken into account.

Actuarial gains and losses arising from experience adjustments and changes in actuarial assumptions are charged or credited to equity in other comprehensive income in the period in which they arise.

The current service cost of the defined benefit plan is recognised in the Consolidated Financial Statements in employee benefit expense, except where included in the cost of an asset. The current service cost reflects the increase in the defined benefit obligation resulting from employee service in the current year, benefit changes, curtailments and settlements.

Past-service costs are recognised immediately in the consolidated income statement.

The net interest cost is calculated by applying the discount rate to the net balance of the defined benefit obligation and the fair value of plan assets. This cost is included in employee benefit expense in the Consolidated Financial Statements.

### 2.18 Current and deferred income tax

The income tax (expense) benefit for the period comprises current and deferred tax. Tax is recognised in the consolidated income statement, except to the extent that it relates to items recognised in other comprehensive income or directly in equity. In this case, the tax is also recognised in other comprehensive income or directly in equity, respectively.

#### (a) Current income tax

The current income tax charge is calculated on the basis of the tax laws enacted or substantively enacted at the balance sheet date in the countries where the Company and the Company's subsidiaries operate and generate taxable income. Management periodically evaluates positions taken in tax returns with respect to situations in which applicable tax regulation is subject to interpretation. It establishes provisions where appropriate on the basis of amounts expected to be paid to the tax authorities.

## Notes to the Consolidated Financial Statements

**2 SUMMARY OF SIGNIFICANT ACCOUNTING POLICIES** (Continued)**2.18 Current and deferred income tax** (Continued)*(b) Deferred income tax**(i) Inside basis differences*

Deferred income tax is recognised, using the balance sheet liability method, on temporary differences arising between the tax bases of assets and liabilities and their carrying amounts in the Consolidated Financial Statements. Deferred income tax is determined using tax rates (and laws) that have been enacted or substantively enacted by the balance sheet date and are expected to apply when the related deferred income tax asset is realised or the deferred income tax liability is settled.

Deferred income tax assets are recognised only to the extent that it is probable that future taxable profit will be available against which the temporary differences can be utilised.

*(ii) Outside basis differences*

Deferred income taxes are recognised on temporary differences arising on investments in subsidiaries and joint arrangements, except where the Group is able to control the timing of the reversal of the temporary difference and it is probable that the temporary difference will not reverse in the foreseeable future.

*(c) Offsetting*

Deferred income tax assets and liabilities are offset when there is a legally enforceable right to offset current tax assets against current tax liabilities and when the deferred income tax assets and liabilities relate to income taxes levied by the same taxation authority on either the taxable entity or different taxable entities where there is an intention to settle the balances on a net basis.

*(d) Uncertainty over income tax treatments*

In assessing any uncertainty over income tax treatments, the Group considers whether it is probable that the relevant tax authority will accept the uncertain tax treatment used, or proposed to be used by individual group entities in their income tax filings. If it is probable, the current and deferred taxes are determined consistently with the tax treatment in the income tax filings. If it is not probable that the relevant taxation authority will accept an uncertain tax treatment, the effect of each uncertainty is reflected by using either the most likely amount or the expected value.

**2.19 Provisions**

Provisions for restructuring, litigation, environmental liabilities, warranties, decommissioning and other are recognised when: the Group has a present legal or constructive obligation as a result of past events; it is probable that an outflow of resources will be required to settle the obligation; and the amount of the obligation can be reliably estimated. Restructuring provisions primarily comprise employee payments. Provisions are not recognised for future operating losses.

Provisions are measured at the present value of the expenditures expected to be required to settle the obligation using a pre-tax rate that reflects current market assessments of the time value of money and the risks specific to the obligation. The increase in the provision due to passage of time is recognised as interest expense.

## Notes to the Consolidated Financial Statements

**2 SUMMARY OF SIGNIFICANT ACCOUNTING POLICIES** (Continued)**2.20 Trade payables**

Trade payables are obligations to pay for goods or services that have been acquired in the ordinary course of business from suppliers. Trade payables are classified as current liabilities if payment is due within one year or less (or in the normal operating cycle of the business if longer). If not, they are presented as non-current liabilities.

**2.21 Revenue recognition**

See note 5 for details on the Group's revenue recognition policy.

**2.22 Leases**

The Group recognises a right-of-use asset (**ROU asset**) and lease liability on the Consolidated Financial Statements for all leases with a term longer than 12 months.

Lease liabilities are measured at the present value of lease payments that are unpaid at the commencement date, discounted using the applicable incremental borrowing rate at the beginning of the lease. IFRS 16 'Leases' (**IFRS 16**) requires that the rate implicit in the lease be used if readily determinable. Generally, implicit rates are not readily determinable in our contracts and the incremental borrowing rate is used for each lease arrangement. The incremental borrowing rates are determined using rates specific to the term of the lease, economic environments where lease activity is concentrated, value of lease portfolio and assuming full collateralisation of the loans.

ROU assets are measured at cost, less accumulated depreciation and any accumulated impairment losses. Any remeasurement of a specific lease liability results in a corresponding adjustment to the ROU asset. The adjustment can be positive or negative. Depreciation of the ROU asset is calculated in accordance with IAS 16 'Property, Plant and Equipment', and is recorded straight-line over the shorter of the lease term and the useful life of the ROU asset.

For all asset classes, the Group accounts for each lease component of a contract and its associated non-lease components as a single lease component, rather than allocating a stand-alone value to each component of the lease. The Group does not recognise ROU assets and lease liabilities for short-term leases that have a lease term of 12 months or less and leases of low-value assets. The Group recognises the lease payments associated with these leases as an expense on a straight-line basis over the lease term.

For the purpose of calculating lease obligations, the Group's lease terms may include options to extend or terminate the lease when it is reasonably certain that the Group will exercise such option. The Group's leases do not contain material residual value guarantees or material restrictive covenants.

The majority of the Group's global lease portfolio represents leases of real-estate, such as manufacturing facilities and office buildings, while the remainder primarily represents vehicles. The Group determines if an arrangement contains a lease at inception. The majority of the Group's lease arrangements are comprised of fixed payments and a limited number of these arrangements include a variable payment component based on certain index fluctuations.

## Notes to the Consolidated Financial Statements

**2 SUMMARY OF SIGNIFICANT ACCOUNTING POLICIES** (Continued)**2.23 Share-based payment**

The Group established an equity-settled, share-based compensation plan in June 2014, under which the Group receives services from certain employees as consideration for equity instruments (**options**) of the Group. The fair value of the employee services received in exchange for the grant of the options is recognised as an expense with a corresponding increase in equity (**share-based compensation reserve**). The total amount to be expensed is determined by reference to the fair value of the options granted, excluding the impact of any non-market performance and service vesting conditions (for example, profitability, sales growth targets and remaining an employee of the entity over a specified time period).

When the options are exercised, the Group issues new shares. The proceeds received net of any directly attributable transaction costs are credited to share capital (nominal value) and share premium.

The Group established performance awards in November 2020 and June 2021 under which the Group receives services from certain employees as consideration for performance awards that are indexed to the share price of the Group. The fair value of the employee services received in exchange for the grant of the performance award is recognised as an expense and a corresponding liability. The total amount to be expensed is determined by reference to the positive difference between the stock price on the vesting date and the initial stock price for the performance award.

Non-market performance, if any, and service conditions are included in assumptions about the number of options and performance awards that are expected to vest. The total expense is recognised over the vesting period, which is the period over which all the specified vesting conditions are to be satisfied.

At the end of each reporting period, the Group revises its estimates of the number of options and performance awards that are expected to vest based on the non-market performance, if any, and service conditions. It recognises the impact of the revision to original estimates, if any, in the Consolidated Financial Statements, with a corresponding adjustment to equity for the options and liability for the performance awards.

**2.24 Government grants**

The Group periodically receives government grants in support of various business initiatives. Grants from the government are recognised at their fair value where there is reasonable assurance that the grant will be received and the Group will comply with all attached conditions. Government grants used to purchase, construct or otherwise acquire property, plant and equipment are deducted from the cost of the related asset. Government grants that are receivable as compensation for expenses or losses already incurred or for the purpose of giving immediate financial support to the Group with no future related costs are recognised as income in the period in which they become receivable.

**2.25 Dividend distribution**

Dividend distribution to the Company's shareholders is recognised as a liability in the Group's and the Company's financial statements in the period in which the dividends are appropriately authorised and no longer at the discretion of the Group or the Company.

## 2 SUMMARY OF SIGNIFICANT ACCOUNTING POLICIES (Continued)

### 2.26 New/revised standards, amendments to standards and interpretations

#### (a) *New and amended standards adopted by the Group*

The Group has adopted the following amendments which are relevant to the Group and mandatory for the accounting period beginning on January 1, 2022.

Amendments to IAS 16	Property, Plant and Equipment: Proceeds before Intended Use
Amendments to IAS 37	Provisions, Contingent Liabilities and Contingent Assets: Onerous Contracts – Costs of Fulfilling a Contract
Amendments to IFRS Standards	Annual Improvements to IFRS Standards 2018–2020

The adoption of these amendments did not have a significant effect on the Consolidated Financial Statements.

#### (b) *New and amended standards and interpretations not yet adopted by the Group*

The following new standards, amendments to standards and interpretations relevant to the Group have been issued but are not yet effective for the financial year beginning January 1, 2022 and have not been early adopted:

Amendments to IAS 1	Classification of Liabilities as Current or Non-current <sup>(ii)</sup>
Amendments to IAS 1	Non-current Liabilities with Covenants <sup>(ii)</sup>
Amendments to IAS 1 and IFRS Practice Statement 2	Disclosure of Accounting Policies <sup>(i)</sup>
Amendments to IAS 8	Definition of Accounting Estimates <sup>(i)</sup>
Amendments to IAS 12	Deferred Tax related to Assets and Liabilities arising from a Single Transaction <sup>(i)</sup>

Notes:

(i) Effective for annual periods beginning on or after January 1, 2023

(ii) Effective for annual periods beginning on or after January 1, 2024

Management has assessed the application of the above new and amended standards and interpretations relevant to the Group and anticipate that there is no material impact on the Consolidated Financial Statements.

## Notes to the Consolidated Financial Statements

### 3 FINANCIAL RISK MANAGEMENT

#### 3.1 Financial risk factors

The Group's activities expose it to a variety of financial risks: market risk (including foreign exchange risk and cash flow interest rate risk), credit risk and liquidity risk. The Group's overall risk management programme focuses on the unpredictability of financial markets and seeks to minimise potential adverse effects on the Group's financial performance.

The Group's treasury department focuses on minimising potential adverse effects on the Group's financial performance.

(a) *Market risk*

The objective of market risk management is to manage and control market risk exposures within acceptable parameters while optimising the return.

(i) Foreign exchange risk

The Group operates internationally but is exposed to foreign exchange risk arising from various currency exposures. Management monitors and analyses expected exchange rate developments and considers hedging foreign currency exposure should the need arise.

(ii) Cash flow and fair value interest rate risk

The Group's interest rate risk primarily arises from current and non-current borrowings. Changes in interest rates on borrowings issued at variable rates expose the Group to cash flow interest rate risk. Borrowings obtained at fixed rates expose the Group to fair value interest rate risk. As at December 31, 2022 and December 31, 2021, all of the Group's outstanding borrowings were in floating rate instruments with undrawn facilities with floating interest rates. In the event there is a change in market conditions the Group will assess the costs and benefits of both variable and fixed rate borrowings and enter into interest rate swaps should the need arise. The Group does not currently hold any interest rate swaps.

As at December 31, 2022, if the interest rates had been 100 basis points higher (lower) than the prevailing rate, with all other variables held constant, profit before income tax for the year ended December 31, 2022 would have been US\$1,132,000 (year ended December 31, 2021: US\$984,000) lower (higher).

(b) *Credit risk*

The Group sells to automotive manufacturers throughout the world. Credit risk arises from deposits with banks and financial institutions as well as credit exposures to customers, including outstanding receivables. The treasury department is responsible for managing and analysing the credit risk for each new customer before standard payment and delivery terms and conditions are offered. The customer's creditworthiness is assessed based on a number of variables.

The Group considers the probability of default upon initial recognition of an asset and whether there has been a significant increase in credit risk on an on-going basis throughout each reporting period. Financial assets are written off when there is no reasonable expectation of recovery, such as the debtor failing to engage in a repayment plan with the Group. Where financial assets have been written off, the Group continues to engage in enforcement activity to attempt to recover the receivable due. Where recoveries are made, these are recognised in profit or loss.

## Notes to the Consolidated Financial Statements

**3 FINANCIAL RISK MANAGEMENT** (Continued)

**3.1 Financial risk factors** (Continued)

 (b) *Credit risk* (Continued)

The Group's largest customer is General Motors Company and subsidiaries (**GM**) and its affiliates, which comprised 32% of revenues during the year ended December 31, 2022 (year ended December 31, 2021: 32%). Trade receivables from GM and its affiliates was 29% of total trade receivables as at December 31, 2022 (December 31, 2021: 26%).

The Group monitors the credit ratings of its banks and financial institutions. As at December 31, 2022, the Group holds approximately 71% (December 31, 2021: 81%) of its cash in financial institutions with credit ratings of A3 (Moody's) or higher, meaning the institutions have a very strong to extremely strong capacity to meet financial commitments. The majority of the remaining cash is held in banks within investment grade.

 (c) *Liquidity risk*

The Group monitors forecasts of liquidity requirements to ensure it has sufficient cash to meet operational needs, while maintaining sufficient availability on its undrawn committed borrowing facilities as to not breach borrowing limits or covenants (where applicable) on any of its facilities. The Group's forecasting takes into consideration debt financing plans, covenant compliance and if applicable, external regulatory or legal requirements.

The tables below analyse the Group's financial liabilities and lease liabilities. The categories are based on the remaining period as at the balance sheet date to the contractual maturity date. The amounts disclosed are the contractual undiscounted cash flows including principal and interest.

	Within 1 year US\$'000	1-2 years US\$'000	2-5 years US\$'000	Over 5 years US\$'000
<b>As at December 31, 2022</b>				
Long-term borrowings	1,738	16,118	36,190	–
Lease liabilities	15,020	16,612	26,549	10,499
	<b>15,020</b>	<b>32,730</b>	<b>62,739</b>	<b>10,499</b>
Trade payables	815,402	–	–	–
Other payables and accruals	76,921	5,578	–	–
	Within 1 year US\$'000	1-2 years US\$'000	2-5 years US\$'000	Over 5 years US\$'000
<b>As at December 31, 2021</b>				
Short-term borrowings	84,403	–	–	–
Lease liabilities	15,226	12,071	28,209	16,690
	99,629	12,071	28,209	16,690
Trade payables	666,501	–	–	–
Other payables and accruals	56,353	5,296	–	–

## Notes to the Consolidated Financial Statements

**3 FINANCIAL RISK MANAGEMENT** (Continued)**3.2 Capital management**

The Group's objectives when managing capital are to safeguard the Group's ability to continue as a going concern in order to provide returns to shareholders and maintain an optimal capital structure to reduce the cost of capital. The Group monitors the gearing ratio to evaluate capital efficiency. Gearing ratio is a rate of total borrowings divided by total equity at the end of each year and is displayed as follows:

	As at December 31,	
	2022 US\$'000	2021 US\$'000
Total borrowings (note 16)	49,838	84,403
Total equity	1,977,150	2,002,589
Gearing ratio	2.5%	4.2%

**3.3 Fair value estimation**

The carrying amounts of the Group's current financial assets and liabilities, including cash and cash equivalents, restricted bank deposits, trade receivables and other receivables, trade payables and other payables and accruals and current borrowings approximate their fair values. The fair value of financial liabilities for disclosure purposes is estimated by discounting the future contractual cash flows at the current market interest rate available to the Group for similar financial instruments.

As set out in notes 2.9, 11 and 20, the Group has notes receivable measured at FVOCI and included in Level 2 of the fair value hierarchy as at December 31, 2022 and December 31, 2021. Notes receivable are measured at FVOCI as (i) they are held within a business model whose objective is achieved by collecting contractual cash flows and selling financial assets; and (ii) the contractual terms of the financial asset give rise on specified dates to cash flows that are solely payments of principal and interest on the principal amount outstanding. The fair value of financial assets at FVOCI is estimated by discounting the future contracted cash flows at the current market interest rate that is available to the Group for similar financial instruments. The Group had no other financial assets or liabilities measured at fair value as at December 31, 2022 and December 31, 2021. The different levels are defined as follows:

- The fair value of financial instruments traded in active markets is based on quoted market prices at the balance sheet date. A market is regarded as active if quoted prices are readily and regularly available from an exchange, dealer, broker, industry group, pricing service or regulatory agency; and those prices represent actual and regularly occurring market transactions on an arm's length basis. The quoted market price used for financial assets held by the Group is the current bid price. These instruments are included in **Level 1**.
- The fair value of financial instruments that are not traded in an active market is determined by using valuation techniques. These valuation techniques maximise the use of observable market data where it is available and rely as little as possible on entity specific estimates. If all significant inputs required to fair value an instrument are observable, the instrument is included in **Level 2**.
- If one or more of the significant inputs is not based on observable market data, the instrument is included in **Level 3**.

There were no transfers of financial assets or financial liabilities between fair value hierarchy classifications.



## Notes to the Consolidated Financial Statements

## 4 CRITICAL ACCOUNTING ESTIMATES AND JUDGEMENTS

The Group makes estimates and assumptions concerning the future. The resulting accounting estimates will, by definition, seldom equal the related actual results. In addition, management has applied judgements in the process of applying the Group's accounting policies. The estimates and assumptions that have a significant risk of causing a material adjustment to the carrying amounts of assets and liabilities, and the critical judgement in applying accounting policies that have significant effect on amounts recognised in the Consolidated Financial Statements are addressed below.

Estimates and judgements are continually evaluated and are based on historical experience and other factors, including expectations of future events that are believed to be reasonable under the circumstances.

### (a) Intangible assets

#### (i) Capitalisation

Costs incurred on development projects are recognised as intangible assets when it is probable that the projects will be successful considering the criteria set out in note 2.7. The Group's development activities are tracked and documented to support the basis of determining if and when the criteria were met.

#### (ii) Impairment

The Group is required to test for impairment of intangible development assets not available for use on an annual basis. The recoverable amount is determined based on the higher of fair value less cost to sell and value in use.

Determination of the value in use is an area involving management judgement in order to assess whether the carrying value of the intangible development assets not available for use can be supported by the net present value of future cash flows specific to each development asset. In calculating the net present value of the future cash flows, certain assumptions are required to be made in respect of highly uncertain matters including management's expectations of future unlevered free cash flows and the selection of discount rates to reflect the risks involved.

The Group uses the most recent detailed calculation of that asset's recoverable amount made in a preceding period when all of the following criteria are met: the assets and liabilities of the Group have not changed significantly from the most recent calculation; the most recent calculation resulted in an amount that exceeded the asset's carrying amount by a substantial margin; and based on an analysis of events that have occurred and circumstances that have changed since the most recent calculation, the likelihood that a current recoverable amount determination would be less than the asset's carrying amount is remote.

## Notes to the Consolidated Financial Statements

**4 CRITICAL ACCOUNTING ESTIMATES AND JUDGEMENTS** (Continued)**(b) Warranty provisions**

The Group recognises a provision when there is a present obligation from a past event, a transfer of economic benefits is probable and the amount of costs of the transfer can be estimated reliably.

The Group recognises expected warranty costs for products sold principally at the time of sale of the product or when it is determined that such obligations are probable and can be reasonably estimated. Amounts recorded are based on the Group's estimates of the amount that will eventually be required to settle such obligations. These accruals are based on factors such as specific customer arrangements, past experience, production changes, industry developments and various other considerations. The Group's estimates are adjusted from time to time based on facts and circumstances that impact the status of existing claims.

**(c) Income taxes**

During the year ended December 31, 2021, the Group reached final agreement with the taxing authority that certain dividends declared and paid by a subsidiary of the Company were subject to withholding tax under the tax law at the time of such dividend payments in the amount of US\$2,429,000 and related interest of US\$929,000 which were recorded as income tax expense and finance costs, respectively, in the Consolidated Financial Statements for the year ended December 31, 2021.

Furthermore, the Group is subject to income taxes in numerous jurisdictions. Significant judgement is required in determining the worldwide provision for income taxes. There are many transactions and calculations for which the ultimate tax determination is uncertain. The Group recognises liabilities for anticipated tax audit issues based on estimates of whether additional taxes will be due. The Group believes that its accruals for tax liabilities are adequate for all open audit years based on its assessment of many factors including past experience and interpretations of tax law. This assessment relies on estimates and assumptions and may involve a series of complex judgements about future events. Where the final tax outcome of these matters is different from the amounts that were initially recorded, such differences will impact the current and deferred income tax assets and liabilities in the period in which such determination is made.

Deferred tax assets are recognised only if it is probable that taxable profits will be available against which the deductible temporary differences can be utilised. This determination requires significant judgement regarding the realisability of deferred tax assets. For entities with a recent history of losses, there would need to be convincing other evidence that sufficient taxable profits would be available in the future. When the expectation is different from the original estimate, such differences will impact the recognition of deferred income tax assets and taxation charges in the period in which such estimate is changed.

## 5 REVENUE AND SEGMENT INFORMATION

### 5.1 Revenue from contracts with customers

The Group contracts with customers, which are generally automotive manufacturers and OEMs, to sell steering and driveline systems and components. In connection with these contracts the Group also provides tooling and prototype parts. The Group does not have material significant payment terms as payment is received shortly after the point of sale.

#### *Performance obligations*

The following summarises types of performance obligations identified in a contract with a customer.

Products	Nature, timing of satisfaction of performance obligations, and payment terms.
Production Parts	<p>The Group recognises the majority of revenue for production parts at a point in time upon shipment to the customer and transfer of the title and risk of loss under standard commercial terms.</p> <p>A limited number of the Group’s customer arrangements for customised products with no alternative use provide the Group with the right to payment during the production process. These revenues are recognised over time using the input method as performance obligations under the terms of a contract are satisfied.</p> <p>The amount of revenue recognised is based on the purchase order price. Customers typically pay for the product/prototype based on customary business practices with payment terms ranging from 30 to 90 days.</p>
Tooling	<p>The Group’s development and sale of tooling for customers is performed in connection with the preparations to produce and sell products to its customers. Customers typically pay for the tooling in a lump sum upon acceptance.</p> <p>The Group recognises revenue for tooling over time using the input method as it satisfies its performance obligation. Revenue is recognised to the extent of costs incurred to date for reimbursable tooling from customers.</p>
Engineering Design and Development/Prototypes	<p>The Group recognises non-production related engineering design and development/prototypes revenue, which is normally related to ADAS, performance improvement and business pursuit.</p> <p>The Group recognises revenue for non-production engineering design and development/prototypes revenue over time using the input method as it satisfies its performance obligations.</p>

## Notes to the Consolidated Financial Statements

**5 REVENUE AND SEGMENT INFORMATION** (Continued)**5.1 Revenue from contracts with customers** (Continued)*Contract balances*

The contract assets primarily relate to the Group's rights to consideration for work completed but not billed at the reporting date on production parts, tooling and engineering design and development/prototypes. The contract assets are reclassified into the receivables balance when the rights to receive payment become unconditional. Contract assets are assessed for impairment under the expected credit loss method in IFRS 9. There have been no impairment losses recognised related to contract assets arising from the Group's contracts with customers. Contract liabilities are associated with consideration received from customers in advance of transferring goods promised in a contract. Recognition of revenue is deferred until the related performance obligations are satisfied in the future. The following table provides information about contract assets and contract liabilities from contracts with customers.

	<b>Contract assets<sup>(i)</sup></b> US\$'000	<b>Contract liabilities, Current<sup>(ii)</sup></b> US\$'000	<b>Contract liabilities, Non-current<sup>(ii)</sup></b> US\$'000
<b>Balances as at December 31, 2022</b>	<b>47,718</b>	<b>24,240</b>	<b>104,613</b>
Balances as at December 31, 2021	43,791	23,691	86,737
Change in account balance	3,927	549	17,876

(i) Contract assets are recorded within other current receivables and prepayments. As at January 1, 2021, contract assets amounted to US\$41,664,000 in total.

(ii) Contract liabilities are recorded within deferred revenue. As at January 1, 2021, contract liabilities amounted to US\$90,716,000 in total.

**5.2 Segment information**

The Group's segment information is presented on the basis of internal reports that are regularly reviewed by the Group's CEO in order to allocate resources to the segments and assess their performance. For each of the Group's reportable segments, the Group's CEO reviews internal management reports on a quarterly basis.

The Group classifies its businesses into three reportable segments: North America, Asia Pacific, and Europe, Middle East, Africa and South America (**EMEASA**). All of the Group's operating segments typically offer the same steering and driveline products. The 'Others' category represents parent company activities of the Company and activities of its non-operating direct and indirect subsidiaries, as well as elimination entries between segments.

During 2022, the Company restructured its internal organisation and management structure which resulted in a change in operating segments. The previous North America represented one single operating and reportable segment, which contained a US-based subsidiary, a Mexico-based subsidiary, a US-based intellectual property holding subsidiary and multiple US-based corporate entities. After the restructure, the US-based subsidiary and the Mexico-based subsidiary that make up the North America reportable segment, have been separated and become two operating segments for internal management reporting purposes and have been aggregated into the North America reportable segment.

## Notes to the Consolidated Financial Statements

**5 REVENUE AND SEGMENT INFORMATION** (Continued)**5.2 Segment information** (Continued)

Additionally, multiple US-based corporate entities have been reclassified from the North America segment to the Others category. Certain intangible assets (and the related amortisation expense) and deferred revenue (and the related revenue) of the US-based intellectual property holding subsidiary previously included in the North America segment have been allocated to the respective segment based on the geographical location of subsidiaries generating revenues from these associated production programmes. Comparative information for the year ended December 31, 2021 has been restated under the new segment structure.

The key performance indicator that the Group monitors to manage segment operations is operating income before interest, taxes, depreciation and amortisation, reversals of impairments/impairments on property, plant and equipment and intangible assets and share of results of joint ventures (**Adjusted EBITDA**).

Information about reportable segments and reconciliations of reportable segment revenues is as follows:

	North America US\$'000	Asia Pacific US\$'000	EMEASA US\$'000	Others US\$'000	Total US\$'000
<b>For the year ended December 31, 2022</b>					
Total revenue	2,313,455	994,534	620,550	(48,230)	3,880,309
Inter-segment revenue	(66,381)	(29,346)	(1,372)	56,493	(40,606)
Revenue from external customers	2,247,074	965,188	619,178	8,263	3,839,703
Adjusted EBITDA	173,423	166,218	44,386	(19,202)	364,825
<b>For the year ended December 31, 2021 (Restated)</b>					
Total revenue	2,010,714	842,958	590,876	(39,903)	3,404,645
Inter-segment revenue	(66,506)	(30,465)	(1,633)	52,684	(45,920)
Revenue from external customers	1,944,208	812,493	589,243	12,781	3,358,725
Adjusted EBITDA	173,741	154,009	41,339	(8,326)	360,763

The revenue from external parties reported to the Group's CEO is measured in a manner consistent with that in the Consolidated Financial Statements.

Total assets and total liabilities represent total current and non-current assets and total current and non-current liabilities of the segments and include assets and liabilities between operating segments. Reconciliations of reportable segment total assets and liabilities are as follows:

	North America US\$'000	Asia Pacific US\$'000	EMEASA US\$'000	Others US\$'000	Total US\$'000
<b>As at December 31, 2022</b>					
Total assets	1,730,348	1,162,857	699,174	(257,098)	3,335,281
Total liabilities	843,300	565,739	267,190	(318,098)	1,358,131
<b>As at December 31, 2021 (Restated)</b>					
Total assets	1,653,229	1,079,476	675,880	(202,086)	3,206,499
Total liabilities	691,145	394,329	272,398	(153,962)	1,203,910

## Notes to the Consolidated Financial Statements

**5 REVENUE AND SEGMENT INFORMATION** (Continued)**5.2 Segment information** (Continued)

Adjusted EBITDA includes a non-cash component for revenue recognised from deferred revenue. For the year ended December 31, 2022, the North America segment, Asia Pacific segment and EMEASA segment recognised US\$20,271,000 (year ended December 31, 2021: US\$12,008,000 (restated)), US\$2,824,000 (year ended December 31, 2021: US\$3,607,000 (restated)) and US\$4,592,000 (year ended December 31, 2021: US\$3,730,000 (restated)), respectively. Reconciliations of reportable segment Adjusted EBITDA to the Group's profit before income tax are as follows:

	For the year ended December 31,	
	2022 US\$'000	2021 US\$'000
Adjusted EBITDA from reportable segments	<b>364,825</b>	360,763
Depreciation and amortisation expenses	<b>(269,187)</b>	(252,757)
(Impairments) reversals of impairments on intangible assets, net	<b>(9,317)</b>	7,209
Finance income	<b>8,651</b>	4,426
Finance costs	<b>(3,655)</b>	(6,281)
Share of results of joint ventures	<b>630</b>	653
Profit before income tax	<b>91,947</b>	114,013

In presenting information on the basis of geography, segment revenue is based on the geographical location of subsidiaries and segment assets and liabilities are based on geographical location of the assets.

The geographic distribution of revenue for the years ended December 31, 2022 and 2021 is as follows:

	For the year ended December 31,	
	2022 US\$'000	2021 US\$'000 (Restated)
North America:		
US	<b>1,311,428</b>	1,144,691
Mexico	<b>935,646</b>	799,517
Asia Pacific:		
China	<b>825,239</b>	688,962
Rest of Asia Pacific	<b>139,949</b>	123,531
EMEASA:		
Poland	<b>356,996</b>	370,678
Rest of EMEASA	<b>262,182</b>	218,565
Others	<b>8,263</b>	12,781
	<b>3,839,703</b>	3,358,725

## Notes to the Consolidated Financial Statements

**5 REVENUE AND SEGMENT INFORMATION** (Continued)**5.2 Segment information** (Continued)

The geographic distribution of non-current assets excluding deferred income tax assets as at December 31, 2022 and 2021 is as follows:

	For the year ended December 31,	
	2022 US\$'000	2021 US\$'000 (Restated)
North America:		
US	546,501	569,512
Mexico	446,505	443,424
Asia Pacific:		
China	391,033	357,917
Rest of Asia Pacific	35,344	41,792
EMEASA:		
Poland	305,466	302,063
Rest of EMEASA	96,531	102,831
Others	7,914	17,374
	<b>1,829,294</b>	1,834,913

*Disaggregation of revenue*

	North America US\$'000	Asia Pacific US\$'000	EMEASA US\$'000	Others US\$'000	Total US\$'000
<b>For the year ended December 31, 2022</b>					
Electric Power Steering (EPS)	1,403,851	681,937	525,795	6,747	2,618,330
Steering Columns and Intermediate Shafts (CIS)	339,210	16,079	13,846	556	369,691
Hydraulic Power Steering (HPS)	154,372	2,132	9,604	43	166,151
Driveline Systems (DL)	349,641	265,040	69,933	917	685,531
	<b>2,247,074</b>	<b>965,188</b>	<b>619,178</b>	<b>8,263</b>	<b>3,839,703</b>

	North America US\$'000	Asia Pacific US\$'000	EMEASA US\$'000	Others US\$'000	Total US\$'000
<b>For the year ended December 31, 2021 (Restated)</b>					
EPS	1,263,327	529,073	521,633	11,513	2,325,546
CIS	293,126	15,795	8,234	631	317,786
HPS	119,773	2,280	14,581	314	136,948
DL	267,982	265,345	44,795	323	578,445
	<b>1,944,208</b>	<b>812,493</b>	<b>589,243</b>	<b>12,781</b>	<b>3,358,725</b>

## Notes to the Consolidated Financial Statements

**5 REVENUE AND SEGMENT INFORMATION** (Continued)**5.2 Segment information** (Continued)*Revenue by type*

	For the year ended December 31,	
	2022	2021
	US\$'000	US\$'000
Production parts	<b>3,799,248</b>	3,311,240
Tooling	<b>26,504</b>	32,914
Engineering design and development/prototypes	<b>13,951</b>	14,571
	<b>3,839,703</b>	3,358,725

Customers amounting to 10 percent or more of the Group's revenue are as follows and reported in all segments:

	For the year ended December 31,	
	2022	2021
	US\$'000	US\$'000
GM	<b>1,241,493</b>	1,069,513
Customer A	<b>984,323</b>	906,206
Customer B	<b>628,459</b>	559,709
	<b>2,854,275</b>	2,535,428



## Notes to the Consolidated Financial Statements

## 6 PROPERTY, PLANT AND EQUIPMENT

	Freehold land and land improvements US\$'000	Leasehold improvements US\$'000	Buildings US\$'000	Machinery, equipment and tooling US\$'000	Furniture and office equipment US\$'000	Construction- in-progress US\$'000	Total US\$'000
<b>As at January 1, 2021</b>							
Cost	13,410	20,288	93,241	1,512,538	8,006	117,272	1,764,755
Accumulated depreciation	(2,683)	(11,995)	(17,858)	(719,946)	(2,940)	–	(755,422)
Net book amount	10,727	8,293	75,383	792,592	5,066	117,272	1,009,333
<b>Year ended December 31, 2021</b>							
Opening net book amount	10,727	8,293	75,383	792,592	5,066	117,272	1,009,333
Additions, net <sup>(i)</sup>	331	1,733	758	146,455	3,015	(20,697)	131,595
Disposals	(15)	(149)	(54)	(5,422)	(169)	–	(5,809)
Depreciation	(213)	(1,901)	(2,872)	(128,174)	(905)	–	(134,065)
Exchange differences	(223)	(17)	(673)	(8,205)	(12)	(3,028)	(12,158)
Net book amount as at December 31, 2021	10,607	7,959	72,542	797,246	6,995	93,547	988,896
<b>As at January 1, 2022</b>							
Cost	13,406	19,979	92,779	1,619,165	10,721	93,547	1,849,597
Accumulated depreciation	(2,799)	(12,020)	(20,237)	(821,919)	(3,726)	–	(860,701)
Net book amount	10,607	7,959	72,542	797,246	6,995	93,547	988,896
<b>Year ended December 31, 2022</b>							
Opening net book amount	10,607	7,959	72,542	797,246	6,995	93,547	988,896
Additions, net <sup>(i)</sup>	2,250	1,997	2,358	126,674	3,072	9,684	146,035
Disposals	–	(6)	–	(3,894)	(88)	–	(3,988)
Depreciation	(292)	(1,870)	(2,803)	(127,815)	(1,160)	–	(133,940)
Exchange differences	(194)	(247)	(3,701)	(20,307)	(642)	(720)	(25,811)
Net book amount as at December 31, 2022	12,371	7,833	68,396	771,904	8,177	102,511	971,192
<b>As at December 31, 2022</b>							
Cost	15,396	21,327	90,782	1,673,403	12,791	102,511	1,916,210
Accumulated depreciation	(3,025)	(13,494)	(22,386)	(901,499)	(4,614)	–	(945,018)
Net book amount	12,371	7,833	68,396	771,904	8,177	102,511	971,192

Note:

- (i) Upon completion, transfers from construction-in-progress to other classes of property, plant and equipment are included in additions, net.

## Notes to the Consolidated Financial Statements

**6 PROPERTY, PLANT AND EQUIPMENT** (Continued)

Certain of the Group's property, plant and equipment have been pledged as collateral under the Group's borrowing arrangements. The carrying amounts of property, plant and equipment pledged as collateral were US\$277,809,000 as at December 31, 2022 (December 31, 2021: US\$320,541,000).

Depreciation has been charged to the following function of expenses:

	For the year ended December 31,	
	2022 US\$'000	2021 US\$'000
Cost of sales	<b>117,194</b>	117,185
Engineering and product development costs	<b>10,001</b>	10,010
Administrative expenses	<b>6,745</b>	6,870
	<b>133,940</b>	134,065

The additions to property, plant and equipment for the year ended December 31, 2022 include US\$nil of capitalised borrowing costs (2021: US\$28,000). Borrowing costs were capitalised at the weighted average of the borrowing rates of 4.4% for the year ended December 31, 2021.

**7 LEASES**

The Group's leases are mainly comprised of real-estate and vehicles. Information about leases for which the Group is a lessee is presented below.

**Right-of-use assets**

	Real-Estate US\$'000	Other US\$'000	Total US\$'000
Balance as at December 31, 2021	56,511	6,878	63,389
Depreciation charge for the year ended December 31, 2021	11,364	2,030	13,394
Balance as at December 31, 2022	<b>49,860</b>	<b>12,286</b>	<b>62,146</b>
Depreciation charge for the year ended December 31, 2022	<b>11,439</b>	<b>2,705</b>	<b>14,144</b>

Additions to the ROU assets during the year ended December 31, 2022 were US\$14,356,000 (year ended December 31, 2021: US\$21,357,000).

## Notes to the Consolidated Financial Statements

**7 LEASES** (Continued)**Right-of-use assets** (Continued)

Depreciation has been charged to the following function of expenses:

	For the year ended December 31,	
	2022	2021
	US\$'000	US\$'000
Cost of sales	9,840	8,848
Engineering and product development costs	1,979	1,985
Administrative expenses	2,325	2,561
	<b>14,144</b>	13,394

**Lease liabilities**

(a) Gross lease liabilities – minimum lease payments:

	As at December 31, 2022	As at December 31, 2021
	US\$'000	US\$'000
Within 1 year	15,020	15,226
Between 1 and 2 years	16,612	12,071
Between 2 and 5 years	26,549	28,209
Over 5 years	10,499	16,690
	<b>68,680</b>	72,196
Less: future finance charges	(7,809)	(9,834)
	<b>60,871</b>	62,362

(b) Present value of lease liabilities:

	As at December 31, 2022	As at December 31, 2021
	US\$'000	US\$'000
Within 1 year	12,495	12,390
Between 1 and 2 years	14,626	9,728
Between 2 and 5 years	23,810	24,598
Over 5 years	9,940	15,646
	<b>60,871</b>	62,362
Less: non-current portion	(48,376)	(49,972)
Current portion	<b>12,495</b>	12,390

For the year ended December 31, 2022, the Group recognised interest expense on lease liabilities of US\$2,831,000 (year ended December 31, 2021: US\$3,201,000) in the Consolidated Financial Statements.

For the year ended December 31, 2022, the Group's total cash outflow for leases amounted to US\$14,401,000 (year ended December 31, 2021: US\$13,709,000).

## Notes to the Consolidated Financial Statements

**8 INTANGIBLE ASSETS**

	<b>Product development costs</b>	<b>Computer software development costs</b>	<b>Total</b>
	US\$'000	US\$'000	US\$'000
<b>Cost</b>			
As at January 1, 2021	1,173,907	27,252	1,201,159
Additions	156,385	14	156,399
Impairment	(1,465)	–	(1,465)
Exchange differences	2,646	–	2,646
As at December 31, 2021	1,331,473	27,266	1,358,739
<b>Accumulated amortisation</b>			
As at January 1, 2021	518,722	24,944	543,666
Amortisation	103,976	1,322	105,298
Exchange differences	968	–	968
As at December 31, 2021	623,666	26,266	649,932
<b>Net book amount</b>			
As at December 31, 2021	707,807	1,000	708,807
<b>Cost</b>			
As at January 1, 2022	<b>1,331,473</b>	<b>27,266</b>	<b>1,358,739</b>
Additions	<b>153,159</b>	–	<b>153,159</b>
Impairment	<b>(9,317)</b>	–	<b>(9,317)</b>
Exchange differences	<b>(10,980)</b>	–	<b>(10,980)</b>
As at December 31, 2022	<b>1,464,335</b>	<b>27,266</b>	<b>1,491,601</b>
<b>Accumulated amortisation</b>			
As at January 1, 2022	<b>623,666</b>	<b>26,266</b>	<b>649,932</b>
Amortisation	<b>120,484</b>	<b>619</b>	<b>121,103</b>
Exchange differences	<b>(4,579)</b>	–	<b>(4,579)</b>
As at December 31, 2022	<b>739,571</b>	<b>26,885</b>	<b>766,456</b>
<b>Net book amount</b>			
As at December 31, 2022	<b>724,764</b>	<b>381</b>	<b>725,145</b>

The additions for the year ended December 31, 2022 include US\$6,779,000 of capitalised interest related to the borrowings associated with product development costs (year ended December 31, 2021: US\$9,691,000). Borrowing costs were capitalised at the weighted average of the borrowing rates of 4.0% for the year ended December 31, 2022 (year ended December 31, 2021: 4.4%).

## Notes to the Consolidated Financial Statements

**8 INTANGIBLE ASSETS** (Continued)

Amortisation has been charged to the following function of expenses:

	For the year ended December 31,	
	2022 US\$'000	2021 US\$'000
Cost of sales	120,672	104,385
Administrative expenses	431	913
	<b>121,103</b>	105,298

**Impairment tests**

Capitalised product development costs not yet available for use amounting to US\$286,500,000 as at December 31, 2022 (December 31, 2021: US\$238,600,000) are tested annually based on the recoverable amount of the cash-generating unit to which the intangible asset is related.

The recoverable amount of the cash-generating units is determined based upon value in use from the most recent detailed calculations. The value in use is estimated using the discounted cash flow approach. For significant cash-generating units, the pre-tax discount rates used for the year ended December 31, 2022 to estimate present value of future cash flows range between 11% and 14% (year ended December 31, 2021: between 8% and 12%), which are based on an estimated weighted average cost of capital depending on geographical location and risk factors and includes estimates of country risk premiums. Estimated cash flows are based on the estimated useful life of the cash-generating unit.

In determining value in use, it is necessary to make a series of assumptions to estimate future cash flows. There is risk in future profitability forecasts including, but not limited to, assumptions of customer volumes and commodity pricing. The assumptions for customer volumes and commodity pricing are reviewed annually as part of management's budgeting and strategic planning cycles.

The assumptions related to customer volume and timing of sales to customers may vary due to a number of factors, including variation in demand for customers' products, customers' attempts to manage their inventories, design changes, changes in customers' manufacturing strategy, etc. Accordingly, many of the Group's customers do not commit to long-term production schedules.

The assumptions related to commodity pricing may vary as raw material costs are influenced by several commodities and the volatility of these prices may have an adverse impact on the Group's business. However, to mitigate the risk the Group continues its efforts to pass material, component and supply cost increases to the Group's customers.

During the year ended December 31, 2022, the Group recognised a product development intangible asset impairment within engineering and product development costs of US\$9,317,000 related to programme cancellations and declining volumes on specific customer programmes, with US\$9,284,000 recorded in the Others segment and US\$33,000 recorded in the Asia Pacific segment. During the year ended December 31, 2021, the Group recorded a net reversal of product development intangible asset impairments of US\$7,209,000. The Group recorded customer recovery from previously impaired programmes of US\$8,674,000 in the Consolidated Financial Statements as engineering and product development costs with US\$5,256,000 recorded in the Others segment (restated) and US\$3,418,000 recorded in the EMEASA segment. The Group recorded impairments of US\$1,465,000 related to programme cancellations and declining volumes on specific customer programmes. The impairment is recorded in the Consolidated Financial Statements as engineering and product development costs in the Asia Pacific segment in the amount of US\$527,000 and the Others segment (restated) in the amount of US\$938,000. The intangible asset impairments recorded in the Others segment were a result of the Group's US domiciled intellectual property holdings arrangement.

## Notes to the Consolidated Financial Statements

**9 DEFERRED INCOME TAXES**

The reconciliation of deferred income tax liabilities, net to the consolidated balance sheet is as follows:

	As at December 31,	
	2022	2021
	US\$'000	US\$'000
Deferred income tax assets	<b>13,886</b>	11,361
Deferred income tax liabilities	<b>(18,944)</b>	(26,741)
Deferred income tax liabilities, net	<b>(5,058)</b>	(15,380)

## Notes to the Consolidated Financial Statements

**9 DEFERRED INCOME TAXES** (Continued)

The movement in deferred income tax assets and liabilities during the year, without taking into consideration the offsetting of balances within the same tax jurisdiction, is as follows:

	Property, plant and equipment US\$'000	Retirement benefits and compensation US\$'000	Provisions and accruals US\$'000	Tax losses and credits US\$'000	Intangible assets US\$'000	Others US\$'000	Total US\$'000
<b>Deferred income tax assets</b>							
As at January 1, 2021	3,350	13,071	33,356	53,430	–	17,516	120,723
Credit (charged) to income statement	12,936	62	4,735	28,095	–	(1,344)	44,484
Charged to equity	–	(452)	–	–	–	–	(452)
Exchange differences	(10)	(8)	(14)	(2)	–	(2)	(36)
As at December 31, 2021	16,276	12,673	38,077	81,523	–	16,170	164,719
As at January 1, 2022	<b>16,276</b>	<b>12,673</b>	<b>38,077</b>	<b>81,523</b>	–	<b>16,170</b>	<b>164,719</b>
Credit (charged) to income statement	<b>9,853</b>	<b>1,720</b>	<b>12,027</b>	<b>(59,330)</b>	–	<b>(4,475)</b>	<b>(40,205)</b>
Charged to equity	–	<b>(530)</b>	–	–	–	–	<b>(530)</b>
Exchange differences	<b>78</b>	<b>59</b>	<b>114</b>	<b>14</b>	–	<b>26</b>	<b>291</b>
As at December 31, 2022	<b>26,207</b>	<b>13,922</b>	<b>50,218</b>	<b>22,207</b>	–	<b>11,721</b>	<b>124,275</b>
<b>Deferred income tax liabilities</b>							
As at January 1, 2021	(56,925)	(156)	(1,822)	–	(101,888)	(10,975)	(171,766)
(Charged) credit to income statement	(15,964)	153	(565)	–	11,670	(3,618)	(8,324)
Exchange differences	(3)	–	(4)	–	–	(2)	(9)
As at December 31, 2021	(72,892)	(3)	(2,391)	–	(90,218)	(14,595)	(180,099)
As at January 1, 2022	<b>(72,892)</b>	<b>(3)</b>	<b>(2,391)</b>	–	<b>(90,218)</b>	<b>(14,595)</b>	<b>(180,099)</b>
Credit (charged) to income statement	<b>5,804</b>	<b>(49)</b>	<b>60</b>	–	<b>36,849</b>	<b>8,039</b>	<b>50,703</b>
Exchange differences	<b>21</b>	–	<b>28</b>	–	–	<b>14</b>	<b>63</b>
As at December 31, 2022	<b>(67,067)</b>	<b>(52)</b>	<b>(2,303)</b>	–	<b>(53,369)</b>	<b>(6,542)</b>	<b>(129,333)</b>

## Notes to the Consolidated Financial Statements

**9 DEFERRED INCOME TAXES** (Continued)

Deferred income tax assets are recognised for tax loss carry-forwards and deductible temporary differences to the extent that the realisation of the related tax benefit through future taxable profits is probable. Deferred income tax assets being calculated at applicable tax rates have not been recognised as management believes it is more likely than not that they would not be utilised before expiration as follows:

	<b>As at December 31,</b>	
	<b>2022</b>	<b>2021</b>
	<b>US\$'000</b>	<b>US\$'000</b>
Tax losses and credits	<b>63,076</b>	15,285
Deductible temporary differences	<b>11,032</b>	1,855
	<b>74,108</b>	17,140

As at December 31, 2022, the Group has US\$88,161,000 (December 31, 2021: US\$84,120,000) of worldwide gross NOL carry-forwards, of which US\$25,672,000 does not expire and the remainder expires over the years 2023-2030. The Group has recognised US\$9,124,000 (December 31, 2021: US\$4,254,000) of worldwide losses as deferred tax assets. The remaining tax losses of US\$79,037,000 (December 31, 2021: US\$79,866,000) have not been recognised due to unpredictability of future profit streams. Additionally, the Group has US\$68,290,000 (December 31, 2021: US\$65,466,000) of research tax credits which begin to expire in 2036. The Group has recognised US\$20,331,000 (December 31, 2021: US\$65,466,000) of research tax credits as a deferred tax asset. The remaining tax credits of US\$47,959,000 (December 31, 2021: US\$nil) have not been recognised due to unpredictability of future profit streams.

As at December 31, 2022, deferred income tax liabilities of US\$3,850,000 (December 31, 2021: US\$9,850,000) have been provided for withholding tax that would be payable on the portion of unremitted earnings of certain subsidiaries intended to be distributed in the foreseeable future and it is probable that the temporary differences will not reverse in the foreseeable future. Deferred income tax liabilities have not been recognised on the remaining unremitted earnings because the Group is able to control the timing of reversal of the temporary differences. Unremitted earnings totaled US\$1,993,895,000 as at December 31, 2022 (December 31, 2021: US\$1,779,928,000).

**10 INVENTORIES**

	<b>As at December 31,</b>	
	<b>2022</b>	<b>2021</b>
	<b>US\$'000</b>	<b>US\$'000</b>
Raw materials	<b>229,896</b>	205,137
Work-in-progress	<b>30,252</b>	38,307
Finished goods	<b>49,273</b>	61,140
	<b>309,421</b>	304,584
Less: provision for write-down	<b>(15,729)</b>	(15,952)
	<b>293,692</b>	288,632

The cost of inventories recognised as an expense and included in cost of sales for the year ended December 31, 2022 amounted to US\$3,165,247,000 (year ended December 31, 2021: US\$2,718,211,000).

The carrying amounts of inventories pledged as collateral were US\$114,283,000 as at December 31, 2022 (December 31, 2021: US\$130,265,000).



## Notes to the Consolidated Financial Statements

**11 TRADE RECEIVABLES**

	As at December 31,	
	2022 US\$'000	2021 US\$'000
Trade receivables, gross	<b>754,683</b>	573,535
Notes receivable	<b>50,064</b>	54,617
Less: provision for impairment	<b>(1,579)</b>	(2,074)
	<b>803,168</b>	626,078

As at January 1, 2021, trade receivables from contracts with customers and notes receivable amounted to US\$568,280,000 and US\$24,747,000, respectively.

Certain customers in China pay for goods and services through the use of notes receivable. The Group had notes receivable outstanding in the amount of US\$50,064,000 as at December 31, 2022 (December 31, 2021: US\$54,617,000). As at December 31, 2022, notes receivable totalling US\$nil (December 31, 2021: US\$9,398,000) were pledged to guarantee notes payable in the same amount recorded within trade payables as set out in note 20. As set out in notes 2.9 and 3.3, the notes receivable are measured at FVOCI.

Credit terms range primarily from 30 to 90 days after the invoice date depending on the customer and the geographical region. Ageing analysis of trade and notes receivable based on invoice date is as follows:

	As at December 31,	
	2022 US\$'000	2021 US\$'000
0 to 30 days	<b>564,492</b>	430,460
31 to 60 days	<b>221,079</b>	177,563
61 to 90 days	<b>11,215</b>	16,361
Over 90 days	<b>7,961</b>	3,768
	<b>804,747</b>	628,152

The provision for impairment of receivables includes estimates and assessments of individual receivables based on the expected credit loss method.

Trade receivables of US\$1,579,000 (December 31, 2021: US\$2,074,000) were non-credit impaired as at December 31, 2022 on which provisions were made.

## Notes to the Consolidated Financial Statements

**11 TRADE RECEIVABLES** (Continued)

Movement on the provision for the impairment of trade receivables is as follows:

	For the year ended December 31,	
	2022 US\$'000	2021 US\$'000
<b>As at January 1</b>	<b>2,074</b>	2,565
Reversal of provision	(426)	(370)
Exchange differences	(69)	(121)
<b>As at December 31</b>	<b>1,579</b>	2,074

The carrying amounts of trade receivables pledged as collateral were US\$459,144,000 as at December 31, 2022 (December 31, 2021: US\$362,585,000).

**12 OTHER RECEIVABLES AND PREPAYMENTS**

	As at December 31,	
	2022 US\$'000	2021 US\$'000
Income taxes receivable	<b>49,612</b>	44,717
Other taxes recoverable <sup>(i)</sup>	<b>33,433</b>	24,024
Prepaid assets	<b>47,697</b>	47,145
Contract assets <sup>(ii)</sup>	<b>47,718</b>	43,791
Deposits to vendors	<b>8,614</b>	7,688
Others	<b>9,639</b>	2,542
	<b>196,713</b>	169,907
Less: non-current portion	<b>(47,416)</b>	(50,917)
Current portion	<b>149,297</b>	118,990

Notes:

(i) Balance mainly represents value-added tax recoverable.

(ii) As stated in note 5, the Group has contracts with customers that require revenue to be recognised over time as costs are incurred. Contract assets balance represents rights to consideration for work completed but not billed, at the reporting date on production parts, tooling and engineering and development/prototypes.

**13 RESTRICTED BANK DEPOSITS**

As at December 31, 2022, restricted bank deposits of US\$10,000 (December 31, 2021: US\$9,000) are maintained with banks for issuance of letters of credit and pledges of bank borrowings.

## Notes to the Consolidated Financial Statements

**14 CASH AND CASH EQUIVALENTS**

The Group's RMB balances of US\$122,219,000 are deposited with banks in China as at December 31, 2022 (December 31, 2021: US\$158,975,000). The RMB is not a freely convertible currency. The conversion of these RMB denominated balances into foreign currencies in China is subject to rules and regulations of foreign exchange control promulgated by the China government. Cash balances denominated in RMB will be used as part of the normal operating activities in China and are classified as unrestricted cash on this basis.

**15 OTHER RESERVES**

	Share premium <sup>(i)</sup> US\$'000	Merger reserve <sup>(ii)</sup> US\$'000	Share-based compensation reserve <sup>(iii)</sup> US\$'000	Exchange reserve <sup>(iv)</sup> US\$'000	Total other reserves US\$'000
As at January 1, 2021	-	113,000	6,923	(61,271)	58,652
Value of employee services provided under Share Option Scheme (note 24(a))	-	-	21	-	21
Transfer to share premium under exercise of share options	883	-	(883)	-	-
Proceeds from exercise of share options	1,804	-	-	-	1,804
Dividends paid to shareholders	(1,045)	-	-	-	(1,045)
Exchange differences	-	-	-	(25,539)	(25,539)
<b>As at December 31, 2021</b>	<b>1,642</b>	<b>113,000</b>	<b>6,061</b>	<b>(86,810)</b>	<b>33,893</b>
Value of employee services provided under Share Option Scheme (note 24(a))	-	-	135	-	135
Dividends paid to shareholders	(1,642)	-	-	-	(1,642)
Exchange differences	-	-	-	(56,748)	(56,748)
<b>As at December 31, 2022</b>	<b>-</b>	<b>113,000</b>	<b>6,196</b>	<b>(143,558)</b>	<b>(24,362)</b>

Notes:

- (i) **Share premium**  
Share premium of the Group represents the difference between the fair value of shares issued and their respective par value.
- (ii) **Merger reserve**  
The Company was incorporated on August 21, 2012 and the Group's reorganisation was completed on January 30, 2013. The merger reserve in the Consolidated Financial Statements as at December 31, 2022 and 2021 represent the aggregate amount of share capital of PCM US Steering Holding LLC and PCM (Singapore) Steering Holding Pte. Limited.
- (iii) **Share-based compensation reserve**  
The share-based compensation reserve comprises the value of employee services provided under the share option scheme. The reserve is relieved when options are exercised in the amount of services recognised related to those option.
- (iv) **Exchange reserve**  
Exchange reserve arises from currency translations of all group entities that have a functional currency different from the US dollar being translated into the Group's presentation currency of US dollar.

## Notes to the Consolidated Financial Statements

## 16 BORROWINGS

	As at December 31,	
	2022	2021
	US\$'000	US\$'000
<b>Non-Current</b>		
Borrowings from banks		
– Unsecured <sup>(1a(ii))</sup>	50,283	–
Add: Non-current portion of:		
– Debt issuance costs <sup>(1b)</sup>	(445)	–
<b>Total Non-Current</b>	<b>49,838</b>	<b>–</b>
<b>Current</b>		
Borrowings from banks		
– Secured <sup>(1a(iii))</sup>	–	84,976
Add: current portion of:		
– Debt issuance costs <sup>(1b)</sup>	–	(573)
<b>Total Current</b>	<b>–</b>	<b>84,403</b>
<b>Total borrowings</b>	<b>49,838</b>	<b>84,403</b>

## (1) Notes:

- (a) The Group has the following significant utilised and unutilised bank facilities at the end of the reporting period:
- (i) An unsecured credit facility containing certain financial covenants, consisting of 3 term loan tranches, obtained by a subsidiary of the Company with a balance of US\$50,283,000 as at December 31, 2022 (December 31, 2021: nil). Tranche 1 has a balance of US\$14,367,000 and matures in December 2024. Tranche 2 has a balance of US\$14,367,000 and matures in February 2025. Tranche 3 has a balance of US\$21,549,000 and matures in April 2025. Each tranche bears interest at the China Loan Prime Rate minus 0.25%. The credit facility has no remaining unused capacity as at December 31, 2022.
- (ii) A revolving line of credit of US\$nil as at December 31, 2022 (December 31, 2021: US\$84,976,000) obtained by a subsidiary of the Company which bears interest at LIBOR plus a range of 1.25% to 1.75% per annum, depending on borrowing type, matures in June 2026 and is secured by trade receivables, inventories and machinery and equipment. Availability under the agreement fluctuates according to a borrowing base. In addition, outstanding amounts under the credit facility may become immediately due and payable upon certain events of default, including failure to comply with the financial covenant in the credit agreement, a fixed charge coverage ratio requirement that applies when excess availability under the credit line is less than certain thresholds, or certain other affirmative and negative covenants in the agreement. As at December 31, 2022 the Group has availability of US\$322,039,000 of the US\$325,000,000 line of credit.
- (iii) A factoring facility with availability to borrow up to US\$42,633,000 by a subsidiary of the Company which bears interest at EURIBOR or WIBOR plus 1.50% per annum, is secured by certain receivables. As of December 31, 2022, the subsidiary has availability to borrow based on collateral up to US\$20,552,000.
- (iv) An overdraft facility with availability to borrow up to US\$18,209,000 by a subsidiary of the Company which bears interest at EURIBOR plus 1.50% per annum or WIBOR plus 1.30% per annum, depending on the currency borrowed, is secured by certain receivables and expires in August 2024.

## Notes to the Consolidated Financial Statements

**16 BORROWINGS** (Continued)**(1)** Notes: (Continued)

- (a) The Group has the following significant utilised and unutilised bank facilities at the end of the reporting period: (Continued)
- (v) A revolving line of credit with availability to borrow up to US\$2,415,000 by a subsidiary of the Company which bears interest at the India Marginal Cost of Funds Based Lending Rate + 0.8% per annum, is secured by property, plant and equipment, trade receivables and inventories.
- (vi) A revolving line of credit with availability to borrow up to US\$2,415,000 by a subsidiary of the Company which bears interest at the India Marginal Cost of Funds Based Lending Rate + 0.4% per annum, is secured by property, plant and equipment, trade receivables and inventories.
- (b) The Group capitalised debt issuance costs related to various borrowings as noted above. Amortisation of the debt issuance costs is recognised in the Consolidated Financial Statements as finance cost over the period of the borrowing using the effective interest method. The unamortised balance of debt issuance costs is US\$445,000 as at December 31, 2022 (December 31, 2021: US\$573,000).

**(2) Maturity of borrowings**

	As at December 31,	
	2022	2021
	US\$'000	US\$'000
Within 1 year	–	84,403
Between 1 and 2 years	14,112	–
Between 2 and 5 years	35,726	–
<b>Total borrowings</b>	<b>49,838</b>	84,403

**(3) The carrying amount and fair value of non-current borrowings are as follows:**

	Carrying amount		Fair value	
	As at December 31,		As at December 31,	
	2022	2021	2022	2021
	US\$'000	US\$'000	US\$'000	US\$'000
Bank borrowings	50,283	–	50,331	–

The fair values of bank borrowings are based on discounted cash flows using applicable discount rates based upon the prevailing market rates of interest available to the Group for financial instruments with substantially the same terms and characteristics as at the balance sheet dates. Such discount rates were 3.40% as at December 31, 2022, and were within Level 2 of the fair value hierarchy.

**(4) Weighted average annual interest rates**

	As at December 31,	
	2022	2021
Bank borrowings	3.3%	2.0%

## Notes to the Consolidated Financial Statements

**17 RETIREMENT BENEFITS AND COMPENSATIONS**

	As at December 31,	
	2022	2021
	US\$'000	US\$'000
Pension – defined benefit plans <sup>(a)</sup>	<b>15,443</b>	16,295
Extended disability benefits <sup>(b)</sup>	<b>3,481</b>	2,789
Workers' compensation <sup>(c)</sup>	<b>8,246</b>	7,224
	<b>27,170</b>	26,308
Less: non-current portion	<b>(23,038)</b>	(22,695)
Current portion	<b>4,132</b>	3,613

**(a) Pension – defined benefit plans**

The Group sponsors various defined benefit plans that generally provide benefits based on negotiated amounts for each year of eligible service. The Group's most significant plans are under regulatory frameworks in Mexico, Germany, France, Korea and the US. The US Supplemental Executive Retirement Plan (**US SERP**) is a frozen plan. The plans had no curtailments or settlements affecting the defined benefit obligation.

The Group employs Mercer (U.S.) Inc., an independent qualified actuary, to measure pension costs using the projected unit credit method. The amounts recognised in the Consolidated Financial Statements are determined as follows:

	For the year ended December 31, 2022			For the year ended December 31, 2021		
	Non-US	US SERP	Total	Non-US	US SERP	Total
	plans	US SERP	Total	plans	US SERP	Total
	US\$'000	US\$'000	US\$'000	US\$'000	US\$'000	US\$'000
Present value of funded obligations <sup>(i)</sup>	<b>15,986</b>	<b>1,047</b>	<b>17,033</b>	16,628	1,331	17,959
Fair value of plan assets <sup>(ii)</sup>	<b>(1,590)</b>	–	<b>(1,590)</b>	(1,664)	–	(1,664)
Deficit of funded plans	<b>14,396</b>	<b>1,047</b>	<b>15,443</b>	14,964	1,331	16,295

There is no current requirement for the Group to fund the deficit between the fair value of plan assets and the present value of the defined benefit plan obligations as at December 31, 2022.

## Notes to the Consolidated Financial Statements

**17 RETIREMENT BENEFITS AND COMPENSATIONS (Continued)****(a) Pension – defined benefit plans (Continued)**

(i) Movement in the present value of defined benefit obligations:

	For the year ended December 31, 2022			For the year ended December 31, 2021		
	Non-US plans	US SERP	Total	Non-US plans	US SERP	Total
	US\$'000	US\$'000	US\$'000	US\$'000	US\$'000	US\$'000
Opening balance	16,628	1,331	17,959	18,658	1,519	20,177
Current service cost	1,152	–	1,152	1,277	–	1,277
Interest cost	900	19	919	784	11	795
Gains from changes in financial assumptions	(2,645)	(78)	(2,723)	(2,042)	(24)	(2,066)
Experience losses (gains)	552	(6)	546	156	(6)	150
Losses from changes in demographic assumptions	4	–	4	1	–	1
Exchange differences	191	–	191	(942)	–	(942)
Benefits paid	(796)	(219)	(1,015)	(1,264)	(169)	(1,433)
Ending balance	15,986	1,047	17,033	16,628	1,331	17,959

(ii) Movement in the fair value of plan assets:

	For the year ended December 31, 2022			For the year ended December 31, 2021		
	Non-US plans	US SERP	Total	Non-US plans	US SERP	Total
	US\$'000	US\$'000	US\$'000	US\$'000	US\$'000	US\$'000
Opening balance	(1,664)	–	(1,664)	(1,724)	–	(1,724)
Interest income	(45)	–	(45)	(39)	–	(39)
Loss on plan assets, excluding amounts included in interest income	13	–	13	11	–	11
Administrative expenses	4	–	4	5	–	5
Employer contributions	(778)	(219)	(997)	(1,327)	(169)	(1,496)
Exchange differences	84	–	84	146	–	146
Benefits paid	796	219	1,015	1,264	169	1,433
Ending balance	(1,590)	–	(1,590)	(1,664)	–	(1,664)

## Notes to the Consolidated Financial Statements

**17 RETIREMENT BENEFITS AND COMPENSATIONS** (Continued)**(a) Pension – defined benefit plans** (Continued)

Plan assets comprise as follows:

	As at December 31,	
	2022	2021
Equities	3%	2%
Bonds	2%	2%
Cash and cash equivalents	2%	2%
Others	93%	94%
	<b>100%</b>	100%

Amounts recognised in other comprehensive income:

	For the year ended December 31, 2022			For the year ended December 31, 2021		
	Non-US plans US\$'000	US SERP US\$'000	Total US\$'000	Non-US plans US\$'000	US SERP US\$'000	Total US\$'000
Gains from changes in financial assumptions	2,654	78	2,732	2,042	24	2,066
Experience (losses) gains	(552)	6	(546)	(156)	6	(150)
Losses from changes in demographic assumptions	(4)	–	(4)	(1)	–	(1)
Loss on plan assets, excluding amounts included in interest income	(13)	–	(13)	(11)	–	(11)
Total	<b>2,085</b>	<b>84</b>	<b>2,169</b>	1,874	30	1,904



## Notes to the Consolidated Financial Statements

**17 RETIREMENT BENEFITS AND COMPENSATIONS (Continued)**
**(a) Pension – defined benefit plans (Continued)**

Amount recognised in the Consolidated Financial Statements:

	For the year ended December 31, 2022			For the year ended December 31, 2021		
	Non-US plans US\$'000	US SERP US\$'000	Total US\$'000	Non-US plans US\$'000	US SERP US\$'000	Total US\$'000
Current service cost	1,152	–	1,152	1,277	–	1,277
Interest cost	855	19	874	745	11	756
Administrative expenses	4	–	4	5	–	5
<b>Total</b>	<b>2,011</b>	<b>19</b>	<b>2,030</b>	2,027	11	2,038
<i>Included in:</i>						
Cost of sales	1,441	–	1,441	1,425	–	1,425
Engineering and product development costs	406	–	406	381	–	381
Selling and distribution costs	110	–	110	186	–	186
Administrative expenses	54	19	73	35	11	46
<b>Total</b>	<b>2,011</b>	<b>19</b>	<b>2,030</b>	2,027	11	2,038

Principal actuarial assumptions used were as follows:

	December 31, 2022		December 31, 2021	
	Non-US plans	US SERP	Non-US plans	US SERP
Discount rate	7.90%	4.95%	5.61%	1.55%
Salary increase rate	4.83%	N/A	4.57%	N/A
Price inflation rate	2.00%	N/A	3.16%	N/A
Pension increase rate	3.47%	N/A	1.75%	N/A

## Notes to the Consolidated Financial Statements

**17 RETIREMENT BENEFITS AND COMPENSATIONS** (Continued)**(a) Pension – defined benefit plans** (Continued)

Balances of pension obligations derived from changes in the discount rate and salary increase rate as at the respective year-ends were as follows:

	December 31, 2022			December 31, 2021		
	Non-US plans US\$'000	US SERP US\$'000	Total US\$'000	Non-US plans US\$'000	US SERP US\$'000	Total US\$'000
1% increase in discount rate	14,641	1,026	15,667	15,016	1,300	16,316
1% decrease in discount rate	17,507	1,068	18,575	18,559	1,365	19,924
1% increase in salary increase rate	16,921	N/A	16,921	17,766	N/A	17,766
1% decrease in salary increase rate	15,145	N/A	15,145	15,631	N/A	15,631

The above sensitivity analyses are based on a change in an assumption while holding all other assumptions constant. In practice, this is unlikely to occur and changes in some of the assumptions may be correlated. When calculating the sensitivity of the defined benefit obligation the same actuarial method has been applied in arriving at the pension liability recognised in the Consolidated Financial Statements.

**(b) Extended disability benefits**

Costs associated with extended disability benefits provided to injured employees in the US are accrued throughout the duration of active employment. Workforce demographic data and historical experience are utilised to develop projections of time frames and related expenses for these post-employment benefits based on an actuarially determined estimate.

**(c) Workers' compensation**

The Group is self-insured up to a certain amount of workers' compensation claims for hourly workforce and accrues estimated costs for filed claims based upon an actuarially determined estimate. Workers' compensation liability includes benefits related to medical, dental and vision benefits.

**18 PROVISIONS**

	As at December 31, 2022			As at December 31, 2021		
	Current US\$'000	Non- current US\$'000	Total US\$'000	Current US\$'000	Non- current US\$'000	Total US\$'000
Litigation <sup>(i)</sup>	109	13,053	13,162	140	668	808
Environmental liabilities <sup>(ii)</sup>	150	11,863	12,013	150	11,889	12,039
Warranties <sup>(iii)</sup>	22,462	36,272	58,734	17,098	38,677	55,775
Decommissioning <sup>(iv)</sup>	–	9,818	9,818	–	9,374	9,374
	22,721	71,006	93,727	17,388	60,608	77,996

## Notes to the Consolidated Financial Statements

**18 PROVISIONS** (Continued)

Movement of provisions is as follows:

	Litigation <sup>(i)</sup> US\$'000	Environmental liabilities <sup>(ii)</sup> US\$'000	Warranties <sup>(iii)</sup> US\$'000	Decom- missioning <sup>(iv)</sup> US\$'000	Total US\$'000
<b>As at January 1, 2021</b>	515	12,060	56,574	8,977	78,126
Additions, net	419	(1)	14,446	415	15,279
Payments	(109)	(16)	(14,840)	–	(14,965)
Exchange differences	(17)	(4)	(405)	(18)	(444)
<b>As at December 31, 2021</b>	808	12,039	55,775	9,374	77,996
<b>As at January 1, 2022</b>	<b>808</b>	<b>12,039</b>	<b>55,775</b>	<b>9,374</b>	<b>77,996</b>
Additions, net	<b>12,589</b>	<b>2</b>	<b>21,241</b>	<b>490</b>	<b>34,322</b>
Payments	<b>(249)</b>	<b>(31)</b>	<b>(16,583)</b>	–	<b>(16,863)</b>
Exchange differences	<b>14</b>	<b>3</b>	<b>(1,699)</b>	<b>(46)</b>	<b>(1,728)</b>
<b>As at December 31, 2022</b>	<b>13,162</b>	<b>12,013</b>	<b>58,734</b>	<b>9,818</b>	<b>93,727</b>

Notes:

(i) Litigation

The balance represents a provision primarily for certain employment litigation claims brought against the Group by former directors, who commenced separate legal proceedings against the Group during the second half of 2022 for, among others, the payment of various termination benefits of US\$10,935,000. The Group will contest both cases vigorously.

(ii) Environmental liabilities

A provision is recognised for remediation costs to be incurred for the restoration of the manufacturing sites upon the initial recognition of the related assets.

(iii) Warranties

A provision is recognised for warranty costs associated with products sold to the customer principally at the time of sale or when it is determined that such obligations are probable and can be reasonably estimated.

(iv) Decommissioning

This represents asset retirement obligations at certain of the Group's facilities.

## Notes to the Consolidated Financial Statements

**19 DEFERRED REVENUE**

Contract liabilities are associated with consideration received from customers in advance of transferring goods promised in a contract. The Group periodically receives upfront consideration from customers in connection with engineering, prototyping and pre-production programme-specific activities. These revenue amounts are deferred and recognised over the life of the related programme, which typically ranges between four and eight years. The carrying amount of deferred revenue is as follows:

	As at December 31, 2022			As at December 31, 2021		
	Current US\$'000	Non- current US\$'000	Total US\$'000	Current US\$'000	Non- current US\$'000	Total US\$'000
Pre-production activity	24,240	104,613	128,853	23,691	86,737	110,428

Movement of deferred revenue is as follows:

	As at December 31,	
	2022	2021
	US\$'000	US\$'000
<b>As at January 1</b>	<b>110,428</b>	90,716
Additions	46,589	38,982
Recognised in profit or loss	(27,687)	(19,345)
Exchange differences	(477)	75
<b>As at December 31</b>	<b>128,853</b>	110,428

**20 TRADE PAYABLES**

	As at December 31,	
	2022	2021
	US\$'000	US\$'000
Trade payables	776,257	625,288
Notes payable	39,145	41,213
	<b>815,402</b>	666,501

Certain vendors in China are paid for goods and services through the use of notes payable. Included in trade payables are notes payable issued to suppliers outstanding in the amount of US\$39,145,000 as at December 31, 2022 (December 31, 2021: US\$41,213,000). As at December 31, 2022, notes payable totalling US\$nil (December 31, 2021: US\$9,398,000) were pledged by notes receivable in the same amount recorded within trade receivables as set out in note 11.

## Notes to the Consolidated Financial Statements

**20 TRADE PAYABLES** (Continued)

The ageing analysis of trade payables based on invoice date is as follows:

	As at December 31,	
	2022 US\$'000	2021 US\$'000
0 to 30 days	443,154	389,542
31 to 60 days	228,815	176,742
61 to 90 days	84,666	52,492
91 to 120 days	18,348	9,693
Over 120 days	40,419	38,032
	<b>815,402</b>	666,501

**21 OTHER PAYABLES AND ACCRUALS**

	As at December 31,	
	2022 US\$'000	2021 US\$'000
Accrued expenses	125,417	119,938
Deposits from customers	499	2,007
Other taxes payable	10,818	11,046
Others	13,664	2,447
	<b>150,398</b>	135,438
Less: non-current portion	(15,875)	(15,030)
Current portion	<b>134,523</b>	120,408

**22 OTHER GAINS, NET**

	For the year ended December 31,	
	2022 US\$'000	2021 US\$'000
Foreign exchange gains, net	9,932	10,236
Loss on disposal of property, plant and equipment	(876)	(2,224)
Others	5,918	9,126
	<b>14,974</b>	17,138

## Notes to the Consolidated Financial Statements

**23 EXPENSE BY NATURE**

	For the year ended December 31,	
	2022 US\$'000	2021 US\$'000
Inventories used, including finished goods and work-in-progress	<b>2,542,487</b>	2,106,884
Employee benefit costs (note 24)	<b>495,388</b>	489,739
Temporary labour costs	<b>111,472</b>	107,687
Supplies and tools	<b>198,791</b>	193,743
Depreciation on property, plant and equipment (note 6)	<b>133,940</b>	134,065
Depreciation on right-of-use assets (note 7)	<b>14,144</b>	13,394
Amortisation on intangible assets (note 8)	<b>121,103</b>	105,298
Impairment (reversals) charges on		
– trade receivables (note 11)	<b>(426)</b>	(370)
– intangible assets (note 8) <sup>(i)</sup>	<b>9,317</b>	(7,209)
Reversal of write-down of inventories (note 10)	<b>(223)</b>	(2,403)
Warranty expenses (note 18)	<b>21,241</b>	14,446
Auditors' remuneration		
– audit services	<b>1,791</b>	1,785
– non-audit services	<b>433</b>	208
Others	<b>118,898</b>	103,381
<b>Total cost of sales, engineering and product development costs, selling and distribution, and administrative expenses</b>	<b>3,768,356</b>	3,260,648

Note:

- (i) The amount for the year ended December 31, 2022 represents impairments of US\$9,317,000 (year ended December 31, 2021: US\$1,465,000) related to programme cancellations and declining volumes on specific customer programmes as set out in note 8. The amount for the year ended December 31, 2021 also included income received of US\$8,674,000 due to customer recovery for a previously cancelled customer programme.

**24 EMPLOYEE BENEFIT COSTS**

	For the year ended December 31,	
	2022 US\$'000	2021 US\$'000
Salary expenses	<b>360,891</b>	357,146
Pension costs – defined contribution plans	<b>31,457</b>	28,475
Pension costs – defined benefit plans (note 17)	<b>2,030</b>	2,038
Other employee costs	<b>101,010</b>	102,080
	<b>495,388</b>	489,739

## Notes to the Consolidated Financial Statements

**24 EMPLOYEE BENEFIT COSTS** (Continued)**(a) Share options**

Pursuant to a shareholders' resolution passed on June 5, 2014, the Company adopted a share option scheme (**the Scheme**). The Scheme will remain in force for a period of 10 years commencing from June 5, 2014 and the period within which the option may be exercised must expire no later than 10 years from the relevant date of grant.

The subscription price for the shares under the option to be granted will be determined by the Board of Directors and will be the higher of: (a) the closing price of the shares of the Company as stated in the daily quotations sheet issued by The Stock Exchange of Hong Kong Limited on the date of grant; (b) the average closing price of the shares of the Company as stated in the daily quotations sheet issued by The Stock Exchange of Hong Kong Limited for the five business days immediately preceding the date of grant; or (c) the nominal value of the shares of the Company. The valuation of share options involves the use of option pricing models that involve variables and assumptions that are subject to estimates and subjective assumptions.

The options will be vested and become exercisable after the grantees complete a period of service of 1 to 3 years from the date of grant and subject to the Group achieving its performance targets.

On June 11, 2014, the Board of Directors approved an initial grant of share options under the Scheme, pursuant to which options to subscribe for 11,236,860 shares, representing approximately 0.4499% of the issued share capital of the Company as at the date of grant, were granted to 15 selected participants at the exercise price of HK\$5.150 per share.

On June 10, 2015, the Board of Directors approved a second grant of share options under the Scheme, pursuant to which options to subscribe for 10,358,990 shares, representing approximately 0.415% of the issued share capital of the Company as at the date of grant, were granted to 13 selected participants at the exercise price of HK\$8.610 per share.

On June 10, 2016, the Board of Directors approved a third grant of share options under the Scheme, pursuant to which options to subscribe for 10,602,490 shares, representing approximately 0.424% of the issued share capital of the Company as at the date of grant, were granted to 13 selected participants at the exercise price of HK\$7.584 per share.

On May 29, 2017, the Board of Directors approved a fourth grant of share options under the Scheme, pursuant to which options to subscribe for 11,919,310 shares, representing approximately 0.476% of the issued share capital of the Company as at the date of grant, were granted to 13 selected participants at the exercise price of HK\$11.620 per share.

## Notes to the Consolidated Financial Statements

**24 EMPLOYEE BENEFIT COSTS** (Continued)**(a) Share options** (Continued)

On May 30, 2018, the Board of Directors approved a fifth grant of share options under the Scheme, pursuant to which options to subscribe for 12,972,770 shares, representing approximately 0.518% of the issued share capital of the Company as at the date of grant, were granted to 15 selected participants at the exercise price of HK\$12.456 per share.

On August 21, 2019, the Board of Directors approved a sixth grant of share options under the Scheme, pursuant to which options to subscribe for 13,675,070 shares, representing approximately 0.545% of the issued share capital of the Company as at the date of grant, were granted to 16 selected participants at the exercise price of HK\$6.390 per share.

On October 25, 2022, the Board of Directors approved a seventh grant of share options under the Scheme, pursuant to which options to subscribe for 12,378,120 shares, representing approximately 0.493% of the issued share capital of the Company as at the date of grant, were granted to 14 selected participants at the exercise price of HK\$4.268 per share.

Movements in the number of share options outstanding and their weighted average exercise prices are as follows:

	Weighted average exercise price (per share) HK\$	Outstanding options (thousands)
As at January 1, 2021	8.667	22,138
Exercised	6.246	(2,279)
Expired	9.503	(5,576)
Forfeited	6.390	(1,346)
As at December 31, 2021	8.970	12,937
Exercisable as at December 31, 2021	9.655	10,222
<b>As at January 1, 2022</b>	<b>8.970</b>	<b>12,937</b>
<b>Granted</b>	<b>4.268</b>	<b>12,378</b>
<b>Expired</b>	<b>8.523</b>	<b>(8,779)</b>
<b>Forfeited</b>	<b>9.463</b>	<b>(2,195)</b>
<b>As at December 31, 2022</b>	<b>5.109</b>	<b>14,341</b>
<b>Exercisable as at December 31, 2022</b>	<b>10.413</b>	<b>1,963</b>



## Notes to the Consolidated Financial Statements

**24 EMPLOYEE BENEFIT COSTS** (Continued)**(a) Share options** (Continued)

The weighted average remaining contractual life for the share options outstanding as at December 31, 2022 was 9.00 years (2021: 5.28 years). The range of exercise prices for options outstanding at the end of the year was HK\$4.268 to HK\$12.456 (2021: HK\$5.150 to HK\$12.456).

The weighted average fair value of the options granted during the period, determined using a binomial model, was HK\$2.061. The significant inputs into the model were share price at the measurement date of HK\$4.140, exercise price of HK\$4.268, historical expected volatility over the expected term of 6.00 years, dividend yield of 1.5%, and an annual risk-free interest rate of 4.21%. There were no options granted for the year ended December 31, 2021.

The fair value of the share options charged to the Consolidated Financial Statements was US\$164,000 for the year ended December 31, 2022. The fair value of the share options charged to the Consolidated Financial Statements was US\$nil for the year ended December 31, 2021 as no shares vested during the year due to the performance conditions not being met.

**(b) Directors' emoluments**

The remuneration of each director for the year ended December 31, 2022 is set out below:

	Fees <sup>(ix)</sup> US\$'000	Salary US\$'000	Annual Incentive Compensation <sup>(ii)</sup> US\$'000	Other benefits <sup>(iii)</sup> US\$'000
Mr. LEI, Zili* <sup>(i)(x)</sup>	87	87	86	7
Mr. MILAVEC, Robin Zane <sup>(i)</sup>	–	729	432	149
Mr. ZHAO, Guibin* <sup>(i)(xi)</sup>	–	473	(18)	46
Mr. FAN, Yi <sup>(i)(xii)</sup>	–	123	(2)	58
Mr. WANG, Jian	59	–	–	–
Ms. ZHANG, Wendong	42	–	–	–
Mr. SHI, Shiming <sup>(xiii)</sup>	23	–	–	–
Mr. LIU, Jianjun	62	–	–	–
Mr. WANG, Bin <sup>(xiv)</sup>	37	–	–	–
Mr. YUE, Yun <sup>(xv)</sup>	30	–	–	–
Mr. WEI, Kevin Cheng <sup>(xvi)</sup>	32	–	–	–
Mr. YICK, Wing Fat Simon <sup>(xvii)</sup>	31	–	–	–

## Notes to the Consolidated Financial Statements

**24 EMPLOYEE BENEFIT COSTS** (Continued)**(b) Directors' emoluments** (Continued)

The remuneration of each director for the year ended December 31, 2021 is set out below:

	Fees <sup>(ix)</sup> US\$'000	Salary US\$'000	Annual Incentive Compensation <sup>(ii)</sup> US\$'000	Other benefits <sup>(iii)</sup> US\$'000
Mr. ZHAO, Guibin* <sup>(i)(xi)</sup>	–	1,040	972	56
Mr. MILAVEC, Robin Zane <sup>(i)</sup>	–	485	232	112
Mr. FAN, Yi <sup>(i)(xii)</sup>	–	250	95	69
Mr. WEI, Kevin Cheng <sup>(xvi)</sup>	68	–	–	–
Mr. LIU, Jianjun	56	–	–	–
Mr. YICK, Wing Fat Simon <sup>(xvii)</sup>	68	–	–	–
Mr. LEI, Zili <sup>(x)</sup>	24	–	–	–
Mr. WANG, Jian	124	–	–	–
Ms. ZHANG, Wendong	42	–	–	–
Mr. LIU, Ping <sup>(xviii)</sup>	18	–	–	–

\* CEO of the Company

## Notes:

- (i) Individual is a member of senior management.
- (ii) The annual incentive compensation plan is payable within one year from year-end.
- (iii) Other benefits include payments made for dental, disability and healthcare coverage; contributions to social security and health-saving accounts; and other non-monetary benefits.
- (iv) During the year ended December 31, 2022, no retirement benefits by a defined benefit pension plan operated by the Group were paid or made, directly or indirectly, to or receivable by a director in respect of their services as a director or other services in connection with the management of the affairs of the Company or its subsidiaries (2021: nil).
- (v) During the year ended December 31, 2022, no payments or benefits in respect of termination of director's services were paid or made, directly or indirectly, to a director (2021: nil).
- (vi) During the year ended December 31, 2022, no consideration was provided to or receivable by third parties for making available director's services (2021: nil).
- (vii) There are no loans, quasi-loans or other dealings in favour of the directors, their controlled bodies corporate and connected entities (2021: nil).
- (viii) No significant transactions, arrangements and contracts in relation to the Group's business to which the Company or any of its subsidiaries was a party and in which a director of the Company had a material interest, whether directly or indirectly, subsisted at the end of the year or at any time during the year (2021: nil).
- (ix) Fees paid are in respect to service as a director, other emoluments are in respect of other services in connection with management of the Company or its subsidiaries.

## Notes to the Consolidated Financial Statements

**24 EMPLOYEE BENEFIT COSTS** (Continued)**(b) Directors' emoluments** (Continued)

Notes: (Continued)

- (x) Mr. LEI, Zili was appointed as our non-Executive Director with effect from June 8, 2021, appointed as Chairman with effect from March 16, 2022 and re-designated from a non-Executive Director to an Executive Director and appointed as CEO with effect from June 21, 2022.
- (xi) Mr. ZHAO, Guibin ceased to act as Executive Director and CEO with effect from June 14, 2022.
- (xii) Mr. FAN, Yi ceased to act as Executive Director with effect from June 21, 2022.
- (xiii) Mr. SHI, Shiming was appointed as a non-Executive Director with effect from June 21, 2022.
- (xiv) Mr. WANG, Bin was appointed as a non-Executive Director with effect from June 21, 2022.
- (xv) Mr. YUE, Yun was appointed as a non-Executive Director with effect from June 21, 2022.
- (xvi) Mr. WEI, Kevin Cheng ceased to act as our non-Executive Director with effect from June 21, 2022.
- (xvii) Mr. YICK, Wing Fat Simon ceased to act as our non-Executive Director with effect from June 14, 2022.
- (xviii) Mr. LIU, Ping retired as our non-Executive Director with effect from June 8, 2021.
- (xix) Deferred incentive compensation plans will be settled when all the conditions are met and with approval by the Board of Directors (certain of which with estimates based upon the extent of meeting certain performance targets). During the year ended December 31, 2022, the deferred incentive compensation of Mr. LEI, Zili; Mr. ZHAO, Guibin; Mr. MILAVEC, Robin Zane; Mr. FAN, Yi; Mr. WANG, Jian; Mr. LIU, Ping; Ms. ZHANG, Wendong, Mr. SHI, Shiming, measured according to IFRS, were approximately US\$22,000, (US\$3,462,000), US\$247,000, (US\$327,000), (US\$148,000), US\$nil, (US\$4,000), and US\$5,000 (2021: US\$nil, US\$4,277,000, US\$1,231,000, US\$397,000, US\$370,000, (US\$16,000), US\$23,000, and US\$nil) respectively. The share-based payments of the share option scheme included in the deferred incentive compensation are calculated and disclosed in accordance with the method set out in note 24(a). These disclosed values deviate from the intrinsic value because the Company used the binomial model to calculate the fair value of the options granted on June 11, 2014, June 10, 2015, June 10, 2016, May 29, 2017, May 30, 2018, August 21, 2019, and October 25, 2022 amounting to HK\$2.710, HK\$3.920, HK\$3.320, HK\$4.440, HK\$4.450, HK\$2.590, and HK\$2.061 per option, respectively. When the actual share price is lower than the exercise price of HK\$5.150, HK\$8.610, HK\$7.584, HK\$11.620, HK\$12.456, HK\$6.390, and HK\$4.268 per share for options granted on June 11, 2014, June 10, 2015, June 10, 2016, May 29, 2017, May 30, 2018, August 21, 2019, and October 25, 2022 respectively the options are out-of-money and the holders will not be benefitted by exercising the options.

**(c) Five highest paid individuals**

The five individuals whose emoluments were the highest in the Group for the year ended December 31, 2022 include one director (2021: two directors), whose emoluments are reflected in the analysis presented above. The emoluments payable to the remaining four (2021: three) individuals during the year are as follows:

	For the year ended December 31,	
	2022 US\$'000	2021 US\$'000
Salaries and allowances	1,621	2,302
Annual and deferred incentive compensation	1,535	1,499
Other benefits	647	423
	<b>3,803</b>	4,224

## Notes to the Consolidated Financial Statements

**24 EMPLOYEE BENEFIT COSTS** (Continued)**(c) Five highest paid individuals** (Continued)

The emoluments of the remaining individuals fell within the following bands:

	For the year ended December 31,	
	2022	2021
	Number of individuals	
HK\$4,500,000 – HK\$5,000,000 (US\$573,000 – US\$637,000)	1	–
HK\$6,500,000 – HK\$7,000,000 (US\$828,000 – US\$892,000)	1	–
HK\$7,000,000 – HK\$7,500,000 (US\$892,000 – US\$955,000)	1	–
HK\$8,500,000 – HK\$9,000,000 (US\$1,083,000 – US\$1,147,000)	–	1
HK\$10,500,000 – HK\$11,000,000 (US\$1,338,000 – US\$1,401,000)	1	1
HK\$13,000,000 – HK\$13,500,000 (US\$1,656,000 – US\$1,720,000)	–	1

During the years ended December 31, 2022 and 2021, no emoluments were paid by the Group to the five highest paid individuals as an inducement to join or upon joining the Group or as compensation for loss of office.

**(d) Performance awards**

Pursuant to an award agreement granted on November 13, 2020, the Company granted 16,299,000 units of performance awards to certain eligible individuals determined by the Board of Directors (**2020 Performance Awards**). The 2020 Performance Awards will remain in force for a period beginning on November 13, 2020 and ending on June 30, 2023. 2020 Performance awards will be equally vested in three tranches in 2021, 2022 and 2023 under the circumstance that non-market performance conditions are met. Each unit of performance awards will be settled in cash for appreciation amounts between the stock price of the Company on the end date of the tranche and the initial stock price of HK\$4.36 determined by the Board of Directors.

As at December 31, 2022, the fair value of the outstanding tranche of unit awards granted during November 2020 were determined using a Black-Scholes model of HK\$1.109 per unit (December 31, 2021: HK\$5.491). The outstanding tranche of unit performance awards has maximum cash payout not to exceed HK\$5.509 per unit (HK\$9.869 per unit less initial stock price at grant date of HK\$4.360) or US\$1,025,000 for the remaining tranche (2021: HK\$5.491 per unit (HK\$9.851 per unit less initial stock price at grant date of HK\$4.360) or US\$2,918,000 per tranche). Expected volatility was determined by calculating the historical volatility of the Company's share price over the expected term. The inputs into the model are disclosed as follows:

	As at December 31, 2022	As at December 31, 2021
Initial stock price	HK\$4.360	HK\$4.360
The 30-day average stock price immediately before December 31	HK\$4.940	HK\$9.972
Weighted average expected volatility	55.66%	68.86%
Range of the expected term	0.5 year	0.5 to 1.5 years
Range of risk-free rates	4.76%	0.19% to 0.56%

## Notes to the Consolidated Financial Statements

**24 EMPLOYEE BENEFIT COSTS** (Continued)**(d) Performance awards** (Continued)

For the year ended December 31, 2022, the fair value of the performance awards of (US\$2,564,000) was (credited)/charged to the Consolidated Financial Statements (year ended December 31, 2021: US\$4,875,000). For the year ended December 31, 2022, 2,686,520 units of 2020 Performance Awards were forfeited (year ended December 31, 2021: 2,457,530 units), and nil units (year ended December 31, 2021: 5,202,000 units) of 2020 Performance Awards totaling US\$nil (year ended December 31, 2021: US\$2,974,000) were settled in cash upon vesting. As at December 31, 2022, the payable for performance awards of US\$453,000 was included in 'other payables and accruals' (December 31, 2021: US\$3,017,000).

Pursuant to an award agreement granted on June 1, 2021, the Company granted 18,055,000 units of performance awards to certain eligible individuals determined by the Board of Directors (**2021 Performance Awards**). The 2021 Performance Awards will remain in force for a period beginning on June 1, 2021 and ending on June 30, 2024. 2021 Performance Awards will be equally vested in three tranches in 2022, 2023 and 2024 under the circumstance that non-market performance conditions are met. Each unit of 2021 Performance Awards will be settled in cash for appreciation amounts between the stock price of the Company on the end date of the tranche and the initial stock price of HK\$10.18 determined by the Board of Directors.

As at December 31, 2022, the weighted average fair value of outstanding tranches of unit awards granted in June 2021 were determined using a Black-Scholes model of HK\$0.268 per unit. The outstanding tranches of 2021 Performance Awards have an average maximum cash payout not to exceed HK\$5.860 per unit (HK\$16.040 per unit less initial stock price at grant date of HK\$10.180) or US\$1,440,000 per tranche (2021: HK\$5.346 per unit (HK\$15.526 per unit less initial stock price at grant date of HK\$10.180) or US\$3,404,000 per tranche). Expected volatility was determined by calculating the historical volatility of the Company's share price over the expected term. The inputs into the model are disclosed as follows:

	As at December 31, 2022	As at December 31, 2021
Initial stock price	<b>HK\$10.180</b>	HK\$10.180
The 30-day average stock price immediately before December 31	<b>HK\$4.940</b>	HK\$9.972
Weighted average expected volatility	<b>57.99%</b>	66.70%
Range of the expected term	<b>0.5 to 1.5 years</b>	0.5 to 2.5 years
Range of risk-free rates	<b>4.57% to 4.76%</b>	0.19% to 0.85%

For the year ended December 31, 2022, the fair value of the 2021 Performance Awards of (US\$1,123,000) was (credited)/charged to the Consolidated Financial Statements (year ended December 31, 2021: US\$1,634,000). For the year ended December 31, 2022, 6,253,980 units (year ended December 31, 2021: 3,160,380 units) of 2021 Performance Awards were forfeited. As at December 31, 2022 the payable for the 2021 Performance Awards of US\$511,000 (December 31, 2021: US\$1,634,000) was included in 'other payables and accruals'.

## Notes to the Consolidated Financial Statements

**25 FINANCE INCOME/FINANCE COSTS**

	For the year ended December 31,	
	2022 US\$'000	2021 US\$'000
<b>Finance income</b>		
Interest on bank deposits	<b>3,698</b>	4,426
Interest on income tax refunds/receivables	<b>4,953</b>	–
	<b>8,651</b>	4,426
<b>Finance costs</b>		
Interest on bank borrowings	<b>5,553</b>	6,090
Interest on notes	–	3,753
	<b>5,553</b>	9,843
Interest on leases	<b>2,831</b>	3,201
Other finance costs	<b>2,050</b>	2,956
	<b>10,434</b>	16,000
Less: amount capitalised in qualifying assets (notes 6 and 8)	<b>(6,779)</b>	(9,719)
	<b>3,655</b>	6,281
	<b>4,996</b>	(1,855)

## Notes to the Consolidated Financial Statements

**26 INCOME TAX (EXPENSE) BENEFIT**

	For the year ended December 31,	
	2022 US\$'000	2021 US\$'000
Current income tax expense	<b>(36,932)</b>	(23,770)
Deferred income tax benefit (note 9)	<b>10,498</b>	36,160
	<b>(26,434)</b>	12,390

The Coronavirus Aid, Relief, and Economic Security (**CARES**) Act was passed by the US Congress and signed into law on March 27, 2020. The CARES Act provided for a carryback of any NOL arising in a taxable year beginning after December 31, 2017 and before January 1, 2021, to each of the five taxable years preceding the taxable year in which the loss arises (**Carryback Period**). As a result of this provision, taxpayers take into account such NOLs in the earliest taxable year in the Carryback Period, carrying forward unused amounts to each succeeding taxable year. The Group has applied this provision to its tax calculation for the year ended December 31, 2021 and recognised a benefit of US\$6,832,000 for the NOL carryback.

The Group's profits were mainly generated in the U.S., China, India, Mexico, and Poland where the statutory tax rates are 21%, 25%, 25%, 30%, and 19%, respectively.

During the year ended December 31, 2022, the Group determined that its US net deferred tax assets, mainly R&D credits, were not probable to be fully realised and recorded a decrease in the net deferred tax assets. Consistent with this determination, the Group has not recorded a tax benefit for credits and certain other deferred tax assets generated in 2022 due to US cumulative pre-tax losses.

## Notes to the Consolidated Financial Statements

**26 INCOME TAX (EXPENSE) BENEFIT** (Continued)

The tax on the Group's profit before tax differs from the theoretical amount that would arise from tax calculated at rates applicable to profits in respective countries of the combined entities as follows:

	For the year ended December 31,	
	2022 US\$'000	2021 US\$'000
Profit before income tax	<b>91,947</b>	114,013
Tax calculated at rates applicable to profits in respective countries	<b>(22,450)</b>	(29,924)
Expenses not deductible for tax purposes	<b>(15)</b>	(484)
Non-taxable income	<b>6,880</b>	10,863
Tax credits <sup>(i)</sup>	<b>33,503</b>	13,713
Preferential rates and tax holidays <sup>(ii)</sup>	<b>11,088</b>	13,359
Tax losses and deductible temporary differences for which no deferred tax was recognised <sup>(iii)</sup>	<b>(56,673)</b>	(209)
Rate benefit on US net operating loss <sup>(iv)</sup>	<b>–</b>	6,832
US state and withholding taxes <sup>(v)</sup>	<b>(6,003)</b>	(6,899)
Others	<b>7,236</b>	5,139
<b>Income tax (expense) benefit</b>	<b>(26,434)</b>	12,390

Notes:

- (i) Mainly represents research and development incentives.
- (ii) Derived mainly from profits subject to preferential tax rate in China for high-technology enterprises. Also includes tax exemption fully utilised in 2023 for the Group's investment in Special Economic Zones in Poland according to the relevant Polish tax rules.
- (iii) Includes US tax assets determined not probable to be fully realised.
- (iv) The US CARES Act NOL carryback provided a permanent tax rate benefit.
- (v) Includes withholding taxes on intercompany dividends anticipated to be paid in the foreseeable future.

**27 EARNINGS PER SHARE****(a) Basic**

Basic earnings per share is calculated by dividing the profit attributable to equity holders of the Company by the weighted average number of ordinary shares in issue during the year.

	For the year ended December 31,	
	2022	2021
Profit attributable to the equity holders of the Company (US\$'000)	<b>58,013</b>	118,440
Weighted average number of ordinary shares in issue (thousands)	<b>2,509,824</b>	2,509,004
<b>Basic earnings per share (in US\$)</b>	<b>0.02</b>	0.05



## Notes to the Consolidated Financial Statements

**27 EARNINGS PER SHARE** (Continued)**(b) Diluted**

Diluted earnings per share is calculated by adjusting the weighted average number of ordinary shares outstanding to assume conversion of all dilutive potential ordinary shares. The Company's dilutive potential ordinary shares comprise of shares issued under the Scheme that are vested as at December 31, 2022. The number of shares that would have been issued assuming the exercise of the share options less the number of shares that could have been issued at fair value (determined as the average market price per share for the year ended December 31, 2022) for the same total proceeds is the number of shares issued for no consideration. The resulting number of shares issued for no consideration is included in the weighted average number of ordinary shares within the denominator for calculating diluted earnings per share. For the years ended December 31, 2022 and 2021, the details are within the table below.

	For the year ended December 31,	
	2022	2021
Profit attributable to equity holders of the Company, used to determine diluted earnings per share (US\$'000)	<b>58,013</b>	118,440
Weighted average number of ordinary shares in issue (thousands)	<b>2,509,824</b>	2,509,004
Adjustment for share options (thousands)	<b>59</b>	2,527
Weighted average number of ordinary shares in issue for calculating diluted earnings per share (thousands)	<b>2,509,883</b>	2,511,531
Diluted earnings per share (in US\$)	<b>0.02</b>	0.05

**28 DIVIDENDS**

	For the year ended December 31,	
	2022	2021
	US\$'000	US\$'000
Dividend proposed of US\$0.0047 (2021: US\$0.0095) per share	<b>11,796</b>	23,843

This 2022 dividend was proposed by the directors at a meeting held on March 15, 2023, the date of approval of these Consolidated Financial Statements, which is not reflected as a dividend payable in these Consolidated Financial Statements.

## Notes to the Consolidated Financial Statements

**29 CONSOLIDATED STATEMENTS OF CASH FLOWS****(a) Cash generated from operations**

	For the year ended December 31,	
	2022 US\$'000	2021 US\$'000
Profit before income tax	<b>91,947</b>	114,013
Adjustments for:		
Finance costs	<b>3,655</b>	6,281
Depreciation on property, plant and equipment	<b>133,940</b>	134,065
Depreciation on right-of-use assets	<b>14,144</b>	13,394
Amortisation on intangible assets	<b>121,103</b>	105,298
Impairment charges on intangible assets	<b>9,317</b>	1,465
Recognition of deferred revenue	<b>(27,687)</b>	(19,345)
Impairment reversals on trade receivables	<b>(426)</b>	(370)
Write-down (reversals of write-down) on inventories	<b>186</b>	(2,057)
Share of results of joint ventures	<b>(630)</b>	(653)
Share-based compensation	<b>(3,523)</b>	6,623
Loss on disposal of property, plant and equipment	<b>876</b>	2,224
	<b>342,902</b>	360,938
Changes in working capital:		
Increase in trade receivables and other receivables and prepayments	<b>(231,639)</b>	(32,109)
Increase in inventories	<b>(15,451)</b>	(56,192)
Increase in payables and accruals	<b>172,925</b>	7,145
Increase (decrease) in provisions	<b>17,021</b>	(103)
Increase in retirement benefits and compensations	<b>3,335</b>	236
Increase in deferred revenue	<b>46,589</b>	38,982
Cash generated from operations	<b>335,682</b>	318,897

*Major non-cash transactions*

During the year ended December 31, 2022, the Group purchased property, plant and equipment, which were recorded in payables in the amounts of US\$52,341,000 (year ended December 31, 2021: US\$26,654,000).

During the year ended December 31, 2022, the Group settled trade payables to suppliers with notes received from customers to settle trade receivables in the amount of US\$20,167,000 (year ended December 31, 2021: US\$37,596,000). These transactions were specific to China.

During the year ended December 31, 2022, the Group had non-cash additions to ROU assets and lease liabilities in the amount of US\$14,356,000 (year ended December 31, 2021: US\$21,357,000).

## Notes to the Consolidated Financial Statements

**29 CONSOLIDATED STATEMENTS OF CASH FLOWS** (Continued)**(b) Net borrowings reconciliation**

(i) Movements in net borrowings for the year ended December 31, 2022 are as follows:

	Borrowings due within a year US\$'000	Borrowings due after a year US\$'000	Total US\$'000
As at January 1, 2021	248,636	–	248,636
Cash flows	(164,498)	–	(164,498)
Foreign exchange adjustments	265	–	265
As at December 31, 2021	84,403	–	84,403
Cash flows	<b>(84,976)</b>	<b>55,464</b>	<b>(29,512)</b>
Foreign exchange adjustments	–	<b>(5,181)</b>	<b>(5,181)</b>
Other non-cash movements	<b>573</b>	<b>(445)</b>	<b>128</b>
As at December 31, 2022	–	<b>49,838</b>	<b>49,838</b>

(ii) Movements in net lease liabilities for the year ended December 31, 2022 are as follows:

	Lease liabilities due within a year US\$'000	Lease liabilities due after a year US\$'000	Total US\$'000
As at January 1, 2021	13,527	43,827	57,354
Cash flows	(13,709)	–	(13,709)
Foreign exchange adjustments	(269)	(923)	(1,192)
Other non-cash movements	12,841	7,068	19,909
As at December 31, 2021	12,390	49,972	62,362
Cash flows	<b>(14,401)</b>	–	<b>(14,401)</b>
Foreign exchange adjustments	<b>(449)</b>	<b>(1,927)</b>	<b>(2,376)</b>
Other non-cash movements	<b>14,955</b>	<b>331</b>	<b>15,286</b>
As at December 31, 2022	<b>12,495</b>	<b>48,376</b>	<b>60,871</b>

**30 COMMITMENTS****Capital commitments**

The Group has capital commitments of US\$105,900,000 as at December 31, 2022 to purchase property, plant and equipment which are contracted but not provided for (December 31, 2021: US\$138,185,000).

## Notes to the Consolidated Financial Statements

**31 RELATED PARTY TRANSACTIONS****(a) Transactions with Yubei Steering Systems Co., Ltd. (Yubei Steering) and Xingxiang Addway Automotive Technology Co., Ltd. (Addway), associates of AVIC**

	For the year ended December 31,	
	2022	2021
	US\$'000	US\$'000
Purchase of goods	6,781	2,500

**(b) Transactions with joint ventures**

The following table sets forth the transactions between the Group and its joint ventures.

	For the year ended December 31,	
	2022	2021
	US\$'000	US\$'000
Sale of product, equipment and services <sup>(i)</sup>	97,551	68,664
Purchase of services <sup>(i)</sup>	18,129	10,696

Note:

(i) Services include engineering services, rent, other fees.

Information about the Group's joint ventures is disclosed as follows:

Nexteer (China) Holding Co., Ltd. (**Nexteer China Holding**) (a direct, wholly-owned subsidiary of the Company) holds a 50% ownership interest in a joint venture, Chongqing Nexteer Steering Systems Co., Ltd. (**Chongqing Nexteer**) in Chongqing, China. The joint venture was formed to manufacture and sell steering parts and the remaining 50% interest is held by Chongqing Jianshe Industry (Group) Co., Ltd.

In March 2017, Nexteer China Holding signed a joint venture agreement with Dongfeng Motor Parts and Components (Group) Co., Ltd. to form Dongfeng Nexteer Steering Systems (Wuhan) Co., Ltd. (**Dongfeng Nexteer**). Located in Wuhan, China, the joint venture, equally owned by both parties, was formed to design and manufacture EPS systems for Dongfeng Motor Group Co., Ltd. and its affiliated companies. Subsequent to December 31, 2022, Nexteer China Holding and Dongfeng Motor Parts and Components (Group) Co., Ltd. agreed to dissolve Dongfeng Nexteer and the dissolution is expected to be complete during the year ended December 31, 2023.

In January 2017, Nexteer Automotive Corporation (an indirect, wholly-owned subsidiary of the Company) agreed to form a joint venture with Continental Automotive Systems, Inc. Located in Grand Blanc, US, the joint venture, CNXMotion, LLC (**CNXMotion**), is focused on integrating lateral and longitudinal control for mixed mode and automated driving applications. Subsequent to December 31, 2022, Nexteer Automotive Corporation and Continental Automotive Systems, Inc. agreed to dissolve CNXMotion and the dissolution is expected to be complete during the year ended December 31, 2023.

As at December 31, 2022 the Group's carrying amount of its investments in joint ventures is US\$23,395,000 (December 31, 2021: US\$22,904,000) including US\$16,817,000, US\$6,578,000 and US\$nil related to Chongqing Nexteer, Dongfeng Nexteer and CNXMotion, respectively, (December 31, 2021: US\$15,652,000, US\$7,252,000, US\$nil). For the year ended December 31, 2022, the Group's share of results of its joint ventures amount to US\$630,000 (year ended December 31, 2021: US\$653,000), including share of profits (losses) of US\$4,303,000, (US\$674,000), and (US\$2,999,000) related to Chongqing Nexteer, Dongfeng Nexteer and CNXMotion, respectively, (year ended December 31, 2021: US\$3,691,000, US\$29,000, (US\$3,067,000)). For the year ended December 31, 2022, the Group received a dividend from Chongqing Nexteer in the amount of US\$3,138,000 (year ended December 31, 2021: US\$3,097,000).

## Notes to the Consolidated Financial Statements

**31 RELATED PARTY TRANSACTIONS** (Continued)**(c) Key management compensation**

The remunerations of the CEO, directors and other key management members were as follows:

	For the year ended December 31,	
	2022 US\$'000	2021 US\$'000
Short-term employee benefits	<b>9,658</b>	13,084
Other long-term benefits	<b>125</b>	2,232
Termination benefits <sup>(i)</sup>	<b>–</b>	1,100
Share-based payments	<b>(3,951)</b>	7,269
	<b>5,832</b>	23,685

These remunerations are determined based on the performance of individuals and market trends.

Note:

- (i) See discussion in note 18, Provisions.

## Notes to the Consolidated Financial Statements

**32 BALANCE SHEET OF THE COMPANY**

The balance sheet of the Company on a non-consolidated basis is as follows:

	<b>As at December 31,</b>	
	<b>2022</b>	<b>2021</b>
	<b>US\$'000</b>	<b>US\$'000</b>
<b>ASSETS</b>		
<b>Non-current assets</b>		
Investments in subsidiaries	<b>845,445</b>	845,309
Right-of-use assets	–	114
Other receivables and prepayments	<b>18,500</b>	21,236
	<b>863,945</b>	866,659
<b>Current assets</b>		
Other receivables and prepayments	<b>2,572</b>	1,873
Cash and cash equivalents	<b>96</b>	57
	<b>2,668</b>	1,930
<b>Total assets</b>	<b>866,613</b>	868,589
<b>EQUITY</b>		
<b>Capital and reserves</b>		
Share capital	<b>32,377</b>	32,377
Other reserves	<b>454,925</b>	456,431
Retained earnings	<b>114,754</b>	23,143
<b>Total equity</b>	<b>602,056</b>	511,951
<b>LIABILITIES</b>		
<b>Non-current liabilities</b>		
Lease liabilities	–	75
Deferred income tax liabilities	<b>3,850</b>	9,850
	<b>3,850</b>	9,925
<b>Current liabilities</b>		
Borrowings	<b>255,198</b>	344,209
Lease liabilities	–	39
Other payables and accruals	<b>5,509</b>	2,465
	<b>260,707</b>	346,713
<b>Total liabilities</b>	<b>264,557</b>	356,638
<b>Total equity and liabilities</b>	<b>866,613</b>	868,589

The balance sheet of the Company was approved by the Board of Directors on March 15, 2023 and was signed on its behalf.

**LEI, Zili**

*Director*

**MILAVEC, Robin Zane**

*Director*

## Notes to the Consolidated Financial Statements

**32 BALANCE SHEET OF THE COMPANY** (Continued)

The movement in reserves of the Company on a non-consolidated basis is as follows:

	Share premium US\$'000	Share-based compensation reserve US\$'000	Capital reserve US\$'000	(Accumulated losses) retained earnings US\$'000	Total reserves US\$'000
As at January 1, 2021	–	6,923	448,728	(15,242)	440,409
Profit for the year	–	–	–	60,921	60,921
Value of employee services provided under Share Option Scheme (note 24(a))	–	21	–	–	21
Transfer to share premium under exercise of share options	883	(883)	–	–	–
Exercise of share options	1,804	–	–	–	1,804
Dividends paid to shareholders	(1,045)	–	–	(22,536)	(23,581)
As at December 31, 2021	1,642	6,061	448,728	23,143	479,574
Profit for the year	–	–	–	<b>113,812</b>	<b>113,812</b>
Value of employee services provided under Share Option Scheme (note 24(a))	–	<b>136</b>	–	–	<b>136</b>
Dividends paid to shareholders	<b>(1,642)</b>	–	–	<b>(22,201)</b>	<b>(23,843)</b>
<b>As at December 31, 2022</b>	<b>–</b>	<b>6,197</b>	<b>448,728</b>	<b>114,754</b>	<b>569,679</b>

## Notes to the Consolidated Financial Statements

**33 SHARE CAPITAL**

	Number of ordinary shares	Amount
<i>Issued and fully paid:</i>		
HK\$0.10 each as at January 1, 2021	2,507,544,833	HK\$250,754,483
Exercise of share options	2,279,460	HK\$227,946
HK\$0.10 each as at December 31, 2021	2,509,824,293	HK\$250,982,429
HK\$0.10 each as at December 31, 2022	2,509,824,293	HK\$250,982,429



## Notes to the Consolidated Financial Statements

## 34 PARTICULARS OF PRINCIPAL SUBSIDIARIES AND JOINT VENTURES

	Place of operation, incorporation and date of incorporation	Issued and paid up capital	Attributable equity interest	Principal activities
<b>Subsidiaries</b>				
<i>Directly held:</i>				
Nexteer (China) Holding Co., Ltd. <sup>(i)</sup>	China June 16, 2014	US\$30,000,000	100%	Investment holding
Nexteer UK Holding Ltd.	United Kingdom February 5, 2015	US\$161,120,152	100%	Investment holding
PCM (Singapore) Steering Holding Pte. Limited	Singapore November 4, 2010	US\$197,600,000 and SGD 1	100%	Investment holding
<i>Indirectly held:</i>				
Nexteer Automotive (Suzhou) Co., Ltd. <sup>(i)</sup>	China January 24, 2007	US\$32,800,000	100%	Manufacturing of steering components, regional technical centre
Nexteer Automotive Australia Pty Ltd.	Australia January 23, 2008	AUD\$2,849,108	100%	Customer service centre
Nexteer Automotive Corporation	Delaware, US January 2, 2008	US\$1	100%	Manufacturing of steering and driveline components, global technical centre
Nexteer Automotive France SAS	France March 25, 2008	EUR1,287,000	100%	Customer service centre, engineering centre
Nexteer Automotive Germany GmbH	Germany January 2, 2008	EUR25,000	100%	Customer service centre, engineering centre
Nexteer Automotive India Private Limited	India February 25, 2008	INR207,917,940	100%	Manufacturing of steering and driveline components, software service centre
Nexteer Automotive Italy S.r.l.	Italy January 30, 2008	EUR10,000	100%	Customer support, engineering centre
Nexteer Automotive Japan LLC	Japan February 21, 2008	JPY1	100%	Customer support, engineering centre
Nexteer Automotive Korea Limited	Korea February 28, 2008	KRW 3,400,000,000	100%	Customer support, engineering centre

## Notes to the Consolidated Financial Statements

**34 PARTICULARS OF PRINCIPAL SUBSIDIARIES AND JOINT VENTURES** (Continued)

	Place of operation, incorporation and date of incorporation	Issued and paid up capital	Attributable equity interest	Principal activities
Nexteer Automotive Luxembourg S.à r.l.	Luxembourg November 5, 2013	US\$20,000	100%	Investment holding
Nexteer Automotive Mexico S.de R.L. de C.V.	Mexico June 10, 2014	MXN129,912	100%	Distribution company
Nexteer Automotive Morocco S.à r.l.	Morocco October 12, 2017	EUR59,153,600	100%	Manufacturing of steering and driveline components
Nexteer Automotive Poland sp. z o.o.	Poland January 2, 1997	PLN20,923,750	100%	Manufacturing of steering components, regional technical centre
Nexteer Automotive Systems (Liuzhou) Co., Ltd. <sup>(i)</sup>	China January 8, 2015	US\$10,000,000	100%	Manufacturing of steering components
Nexteer Cayman Finance Limited	Cayman Islands October 21, 2019	US\$2	100%	Intragroup financing
Nexteer Hungary Finance Kft.	Hungary March 5, 2019	US\$12,000	100%	Intragroup financing
Nexteer Hungary Investment Kft.	Hungary February 24, 2020	US\$13,000	100%	Intragroup financing
Nexteer Industria e Comercio de Sistemas Automotivos Ltda.	Brazil February 22, 2007	BRL311,423,316	100%	Manufacturing of steering and driveline components
Nexteer Lingyun Driveline (Wuhu) Co., Ltd. <sup>(i)</sup>	China December 22, 2006	US\$22,400,000	60%	Manufacturing of driveline components
Nexteer Lingyun Driveline (Zhuozhou) Co., Ltd. <sup>(i)</sup>	China October 6, 1995	US\$22,000,000	60%	Manufacturing of driveline components
Nexteer Luxembourg Holding VI S.à r.l. (formerly Rhodes I LLC)	Luxembourg (previously Michigan, US) November 7, 2007	EUR85,000	100%	Investment holding
Nexteer Luxembourg Holding VII S.à r.l. (formerly Rhodes II LLC)	Luxembourg (previously Michigan, US) November 7, 2007	EUR85,000	100%	Investment holding
Nexteer Otomotiv Sanayi ve Ticaret Limited Sirketi	Turkey March 28, 2008	TRY1,105,000	100%	Manufacturing of steering components

## Notes to the Consolidated Financial Statements

## 34 PARTICULARS OF PRINCIPAL SUBSIDIARIES AND JOINT VENTURES (Continued)

	Place of operation, incorporation and date of incorporation	Issued and paid up capital	Attributable equity interest	Principal activities
Nexteer US Holding I LLC	Delaware, US May 18, 2007	–	100%	Investment holding
PCM US Steering Holding LLC	Delaware, US March 9, 2009	–	100%	Investment holding
PT Nexteer Automotive Indonesia	Indonesia March 23, 2016	US\$1,600,000	100%	Manufacturing of steering components
Rhodes Holding I S.à r.l.	Luxembourg January 15, 2008	EUR4,500,000	100%	Investment holding
Rhodes Holding II S.à r.l.	Luxembourg January 15, 2008	EUR4,331,151	100%	Investment holding
Steering Holding Pte. Ltd.	Singapore February 15, 2008	US\$6,400,000 and EUR1	100%	Engineering centre, investment holding
Steering Solutions Corporation	Delaware, US October 29, 2007	US\$1	100%	Investment holding
Steering Solutions Expat Holding Corporation	Delaware, US January 2, 2008	US\$1	100%	Employee support services
Steering Solutions IP Holding Corporation	Delaware, US January 2, 2008	US\$1	100%	Intellectual property management
Steeringmex S. de R.L. de C.V.	Mexico December 14, 2007	MXN100,292,971	100%	Manufacturing of steering and driveline components
<i>Joint ventures:</i>				
Chongqing Nexteer Steering Systems Co., Ltd. <sup>(i)</sup>	China January 22, 2014	RMB120,000,000	50%	Manufacturing of steering components
CNXMotion, LLC <sup>(ii)</sup>	Delaware, US July 18, 2017	–	50%	Research and development centre
Dongfeng Nexteer Steering Systems (Wuhan) Co., Ltd. <sup>(ii)</sup>	China October 23, 2017	RMB150,000,000	50%	Manufacturing of steering components

(i) Foreign-invested enterprise registered under PRC law.

(ii) Subsequent to December 31, 2022, the Group entered into agreements with the joint venture partner to dissolve the joint venture. See note 31(b).

## Five Years' Financial Summary

	For the year ended December 31,				
	2022 US\$'000	2021 US\$'000	2020 US\$'000	2019 US\$'000	2018 US\$'000
<b>RESULTS</b>					
Revenue	<b>3,839,703</b>	3,358,725	3,032,210	3,575,657	3,912,170
Profit before income tax	<b>91,947</b>	114,013	114,462	263,933	410,391
Income tax (expense) benefit	<b>(26,434)</b>	12,390	7,841	(29,275)	(26,045)
Profit for the year	<b>65,513</b>	126,403	122,303	234,658	384,346
Profit for the year attributable to:					
Equity holders of the Company	<b>58,013</b>	118,440	116,766	232,445	379,657
Non-controlling interests	<b>7,500</b>	7,963	5,537	2,213	4,689
	<b>65,513</b>	126,403	122,303	234,658	384,346
Earnings per share, (US\$ per share)					
Basic and diluted	<b>0.02</b>	0.05	0.05	0.09	0.15
<b>ASSETS AND LIABILITIES</b>					
Total assets	<b>3,335,281</b>	3,206,499	3,305,741	3,258,972	3,111,511
Total liabilities	<b>1,358,131</b>	1,203,910	1,384,756	1,407,316	1,401,667
Total equity	<b>1,977,150</b>	2,002,589	1,920,985	1,851,656	1,709,844
Capital and reserves attributable to equity holders of the Company	<b>1,933,825</b>	1,954,629	1,882,002	1,811,981	1,671,810
Non-controlling interests	<b>43,325</b>	47,960	38,983	39,675	38,034
	<b>1,977,150</b>	2,002,589	1,920,985	1,851,656	1,709,844